



In-Plant Trainings

Virtual Platform

Session 4 – Air Treatment





Air Treatment





What is in your compressed air?

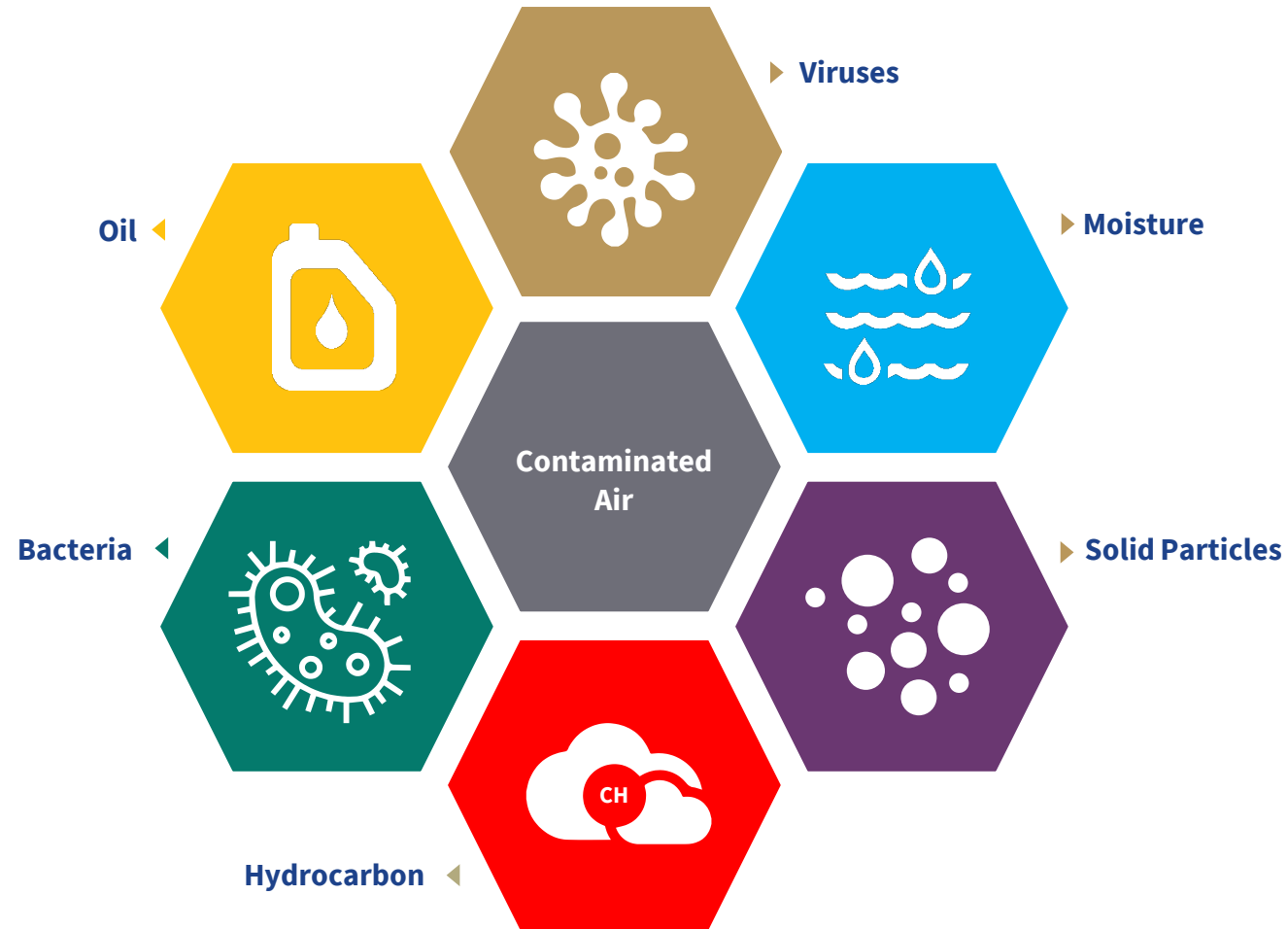

Which Contaminants do we find in compressed air?

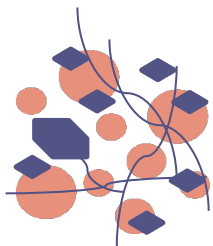

SOLID - PARTICLES



WATER



OIL



GASEOUS CONTAMINANTS

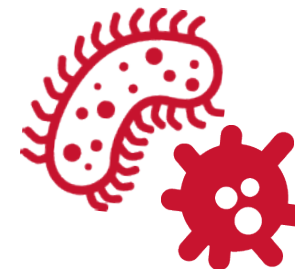

MICROBIOLOGICAL CONTAMINANTS

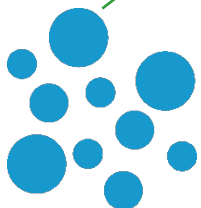

LIQUID



VAPOR (HUMIDITY)



LIQUID (AEROSOL)



VAPOR (HYDROCARBON)

Most relevant to us are dust, water and oil

- Compressed air can contain unwanted substances, such as water in liquid or vapor form, oil in liquid or aerosol form, as well as dust.

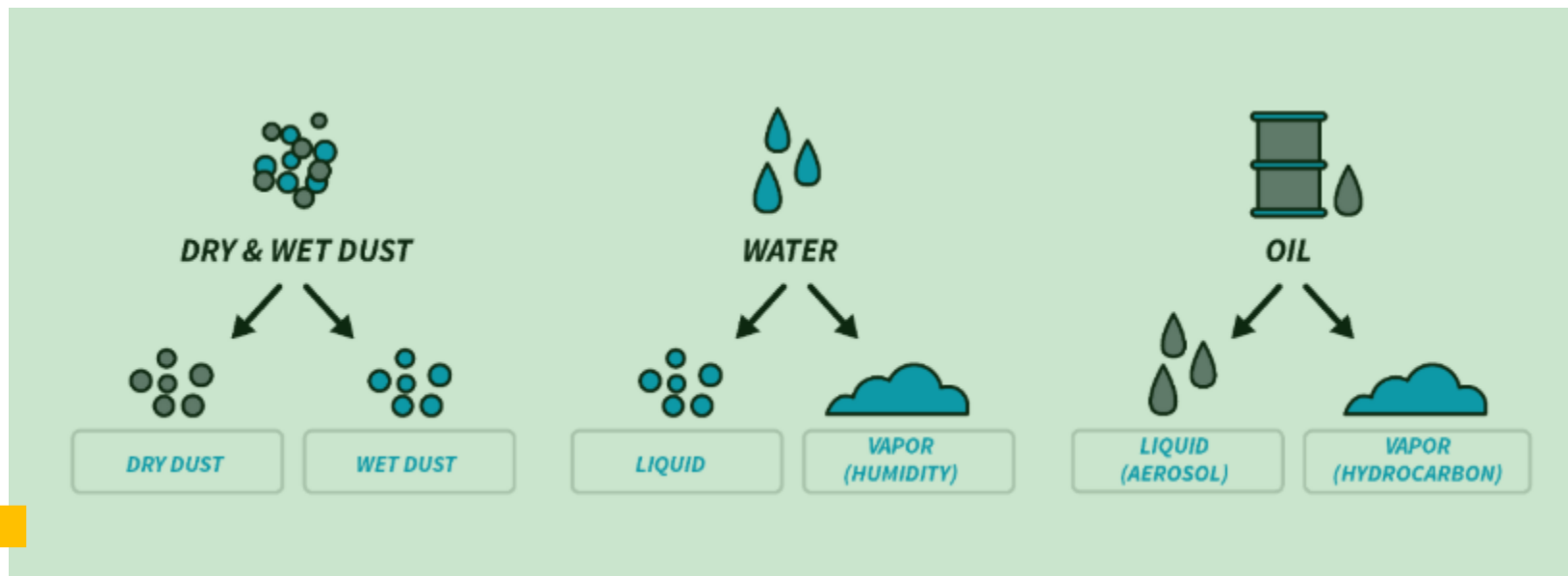

THE RELATIVE SIZE OF PARTICLES

From the COVID-19 pandemic to the U.S. West Coast wildfires, some of the biggest threats now are also the most microscopic.

A particle needs to be 10 microns (μm) or less before it can be inhaled into your respiratory tract. But just how small are these specks?

Here's a look at the relative sizes of some familiar particles \blacktriangleright

HUMAN HAIR 50-180 μm \blacktriangleright
FOR SCALE

FINE BEACH SAND 90 μm \blacktriangleright

GRAIN OF SALT 60 μm \blacktriangleright

WHITE BLOOD CELL 25 μm \blacktriangleright

GRAIN OF POLLEN 15 μm \blacktriangleright

DUST PARTICLE (PM₁₀) <10 μm \blacktriangleright

RED BLOOD CELL 7-8 μm \blacktriangleright

RESPIRATORY DROPLETS 5-10 μm \blacktriangleright

DUST PARTICLE (PM_{2.5}) 2.5 μm \blacktriangleright

BACTERIUM 1-3 μm \blacktriangleright

WILDFIRE SMOKE 0.4-0.7 μm \blacktriangleright

CORONAVIRUS 0.1-0.5 μm \blacktriangleright

T4 BACTERIOPHAGE 0.225 μm \blacktriangleright

ZIKA VIRUS 0.045 μm \blacktriangleright



Pollen can trigger allergic reactions and hay fever—which 1 in 5 Americans experience every year.

Source: Harvard Health

The visibility limits for what the naked eye can see hovers around 10-40 μm .



Respiratory droplets have the potential to carry smaller particles within them, such as dust or coronavirus.



Wildfire smoke can persist in the air for several days, and even months.

ISO 8573-1:2010 – Contaminants and Purity classes

Most used standard to evaluate purity of compressed air

ISO 8573-1:2010	Dirt			Mass concentration mg/m ³	Water		Oil
	Maximum number of particles per m ³				Vapor pressure dewpoint	Liquid g/m ³	Total oil (aerosol liquid and vapor) mg/m ³
	0.1 - 0.5 micron	0.5 - 1 micron	1 - 5 micron				
0	As specified by the equipment user or supplier and more stringent than Class 1						
1	≤ 20000	≤ 400	≤ 10	-	≤ -70°C/-94°F	-	0.01
2	≤ 400000	≤ 6000	≤ 100	-	≤ -40°C/-40°F	-	0.1
3	-	≤ 90000	≤ 1000	-	≤ -20°C/-4°F	-	1
4	-	-	≤ 10000	-	≤ +3°C/+37.4°F	-	5
5	-	-	≤ 100000	-	≤ +7°C/+44.6°F	-	-
6	-	-	-	≤ 5	≤ +10°C/+50°F	-	-
7	-	-	-	5 - 10	-	≤ 0.5	-
8	-	-	-	-	-	0.5 - 5	-
9	-	-	-	-	-	5 - 10	-
X	-	-	-	> 10	-	> 10	> 10

- ISO 8573-1:2010 – Contaminants and Purity classes



ISO 8573-1:2010 – Contaminants and Purity classes

Most used standard to evaluate purity of compressed air

ISO 8573-1:2010	Dirt			Mass concentration mg/m ³	Water		Oil
	Maximum number of particles per m ³				Vapor pressure dewpoint	Liquid g/m ³	Total oil (aerosol liquid and vapor) mg/m ³
	0.1 - 0.5 micron	0.5 - 1 micron	1 - 5 micron				
0	As specified by the equipment user or supplier and more stringent than Class 1						
1	≤ 20000	≤ 400	≤ 10	-	≤ -70°C/-94°F	-	0.01
2	≤ 400000	≤ 6000	≤ 100	-	≤ -40°C/-40°F	-	0.1
3	-	≤ 90000	≤ 1000	-	≤ -20°C/-4°F	-	1
4	-	-	≤ 10000	-	≤ +3°C/+37.4°F	-	5
5	-	-	≤ 100000	-	≤ +7°C/+44.6°F	-	-
6	-	-	-	≤ 5	≤ +10°C/+50°F	-	-
7	-	-	-	5 - 10	-	≤ 0.5	-
8	-	-	-	-	-	0.5 - 5	-
9	-	-	-	-	-	5 - 10	-
X	-	-	-	> 10	-	> 10	> 10

For example, class 2.4.2. means

Dirt: less than or equal to 400,000 particles in the range of 0.1 – 0.5 µm; 6,000 of 0.5 – 1 µm; 100 of 1 – 5 µm

Water: less than or equal to 37.4 °F PDP

Oil: max 0.1 mg/m³

- The **first number** represents the solid particles class
- The **second number** represents the water class
- The **third number** represents the oil class

Compressed Air Testing Kits



Kit Purchase

\$600

Kit Rental

\$60

Manufacturing Air ▾

Dietary Supplements

Food Grade Air

Food Packaging

Instrument / Nuclear

Medical Device

Pet Food

Pharmaceutical

Pure Gas Testing

Microbial Contaminants >

Validations and Qualifications

Environmental ▾

Ambient Air Testing

Contact Plate Testing

Surface Swab Testing

Microbial Contaminants >

- K810 – the AirCheck✓ Kit™ for Particles, Water, and Oil
- K811 – the AirCheck✓ Kit™ for Gases, Particles, Water, and Oil
- KX00 – the AirCheck✓ Kit™ for Microorganisms

Testing Results

ANALYSIS RESULTS

Report Number: 290230 - 0 **Report Date:** **Customer No:** D000556 - 1
Air/Gas Source: OIL FREE SCREW **Order Number:** 95975
Air/Gas Sampled From: COMPRESSED AIR SYSTEM **Sample Date:** 11/09/16
Compared to Air/Gas Specification: BASELINE DIRECT PRODUCT CONTACT AIR/GAS TEST **Date Received:** 11/18/16
EVALUATION **Date Analyzed:** 11/18/16

ANALYTE	SOURCE AIR/GAS	REPORTING LIMITS*
Oxygen (Volume %)	20.9	0.5
Carbon Monoxide (ppmv)	< 1	1
Total Gaseous Hydrocarbons including Methane (ppmv)	2.3	1
Methane (ppmv)	2.1	1
Total Gaseous Hydrocarbons excluding Methane (ppmv)	< 1	1
Carbon Dioxide (ppmv)	478	25
Oil Mist & Particulate [COM:147] (mg/m3)	< 0.01	0.01
Oil Mist (mg/m3)	< 0.01	0.01
Particulate (mg/m3)	< 0.01	0.01
Water (ppmv)	< 2	2
Water (Dew Point °F)	< -95	-95

N/A = Not Applicable

COM:147 If reported, Oil Mist and Particulate quantitative results are reported as a combined amount until the value approaches 0.1mg/m3.

Analyzed By: VICKY EVANS SAM L. VASQUEZ
Using: 70SOP-41 REV17 GC: 70-09, 70SOP-36 REV12 BALANCE: 70-03, 70SOP-39 REV2 (TRIAC: BLD)
Sample Media: S B: KF192 Filter: XP2210 MO: 1070 HH: 192

* Reporting Limit is the lowest concentration at which an analyte can be detected in a sample and its concentration can be reported with a reasonable degree of accuracy and precision.

Testing Results

ANALYSIS RESULTS

Report Number:	290230 - 0	Report Date:	Customer No: D000556 - 1
Air/Gas Source:	OIL FREE SCREW	Order Number:	95975
Air/Gas Sampled From:	COMPRESSED AIR SYSTEM	Sample Date:	11/09/16
Compared to Air/Gas Specification:	BASELINE DIRECT PRODUCT CONTACT AIR/GAS TEST EVALUATION	Date Received:	11/18/16
		Date Analyzed:	11/18/16

ANALYTE	SOURCE AIR/GAS	REPORTING LIMITS*
Nitrogen (Volume %)	78.5	0.5
Halogenated Hydrocarbons (ppmv)	< 1	1

What About Microbial Contaminants?

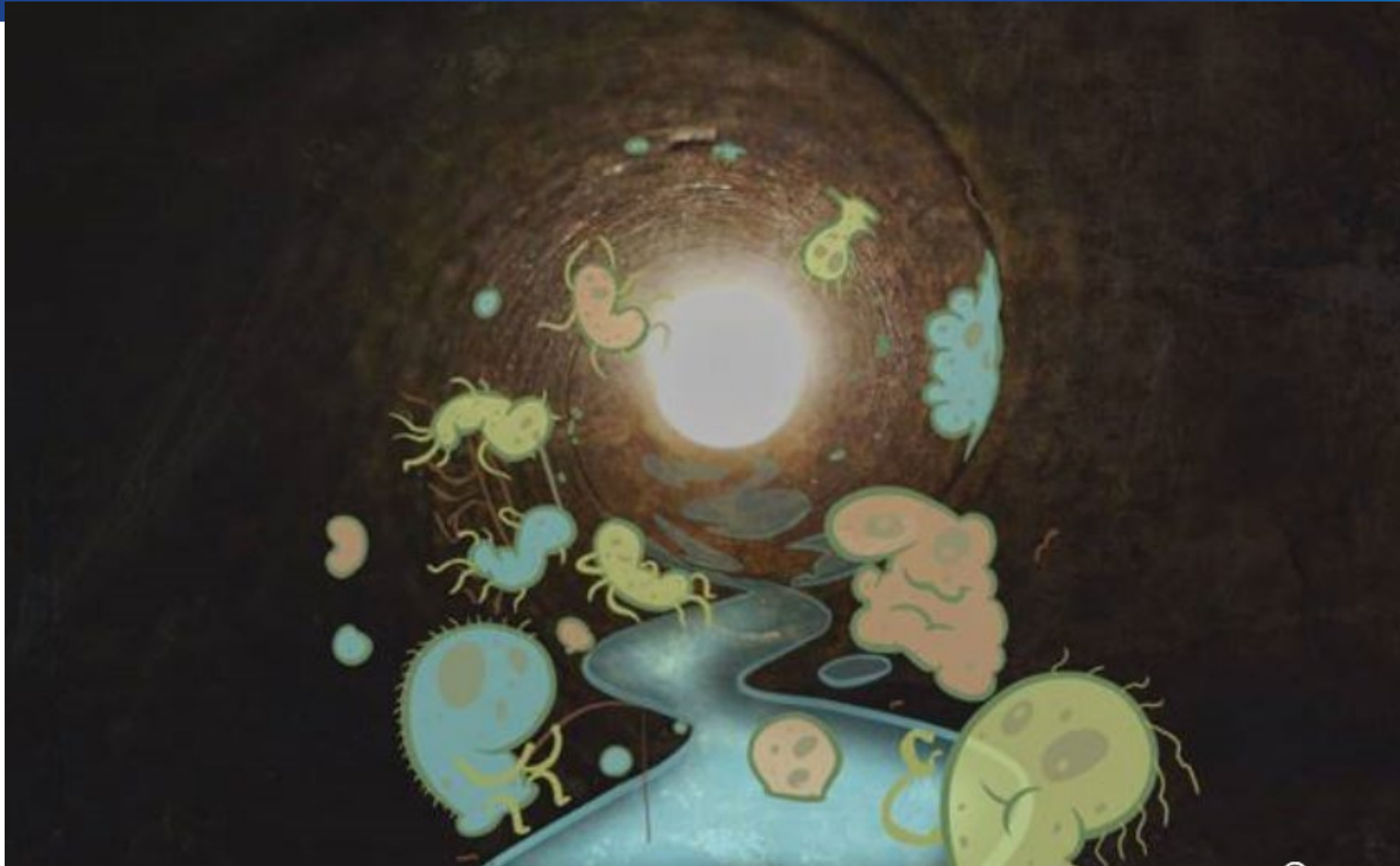

Testing Results

ANALYSIS RESULTS

Report Number:	290233 - 0	Report Date:		Customer No:	D000556 - 1
Air/Gas Source:	OIL FREE SCREW			Order Number:	95975
Air/Gas Sampled From:	MOLD AND BACTERIA			Sample Date:	11/09/16
Air/Gas Specification:	MOLD/BACTERIA ANALYSIS (no specification comparison)			Date Received:	11/18/16
				Date Analyzed:	11/29/16

ANALYTE	Raw Count	Identification	RESULTS	Reporting Limits*
Mold at source MEA media	0	No Growth	< 34 CFU/M3	34 CFU/M3
Bacteria at source TSA media	0	No Growth	< 34 CFU/M3	34 CFU/M3
Mold Blank MEA media	0	No Growth	< 50 CFU/M3	50 CFU/M3
Bacteria Blank TSA media	0	No Growth	< 50 CFU/M3	50 CFU/M3

CFU stands for Colony-Forming Units:
 In microbiology, a colony-forming unit (CFU, cfu, Cfu) is a unit used to estimate the number of viable bacteria or fungal cells in a sample. Viable is defined as the ability to multiply via binary fission under the controlled conditions.

N/A = Not Applicable
 REFERENCE NUMBER: 151608906

Reported By: MAYRA I. DALVA
Using: (TRI AC: MI)
Sample Media: MBS: 22181 MBB: 11711

* Reporting Limit is the lowest concentration at which an analyte can be detected in a sample and its concentration can be reported with a reasonable degree of accuracy and precision.

Wet Compressed Air

- Compressed air must be dried. This is an undeniable statement of fact.
 - Today's modern industry can no longer tolerate the problems of wet, dirty compressed air.
 - Wet air causes rust, pitting, blockages, and freeze-ups, with resultant component failure and product rejection.
 - Wet air is a major contributor of downtime, causing millions of dollars of lost production.
 - Measuring dew point in industrial settings is the only way to ensure that downstream production equipment does not undergo corrosive damage and the quality of end products is not affected by any moisture contaminant.

EFFECTS OF WATER CONTAMINATION

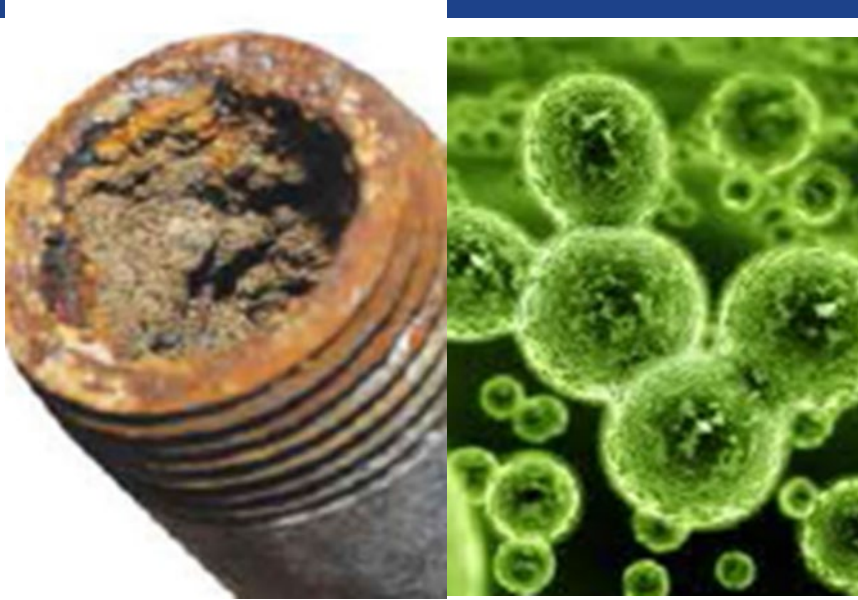

- Washing away required lubricants.
- Causing rust and scale to form within pipelines.
- Increased wear and maintenance of pneumatic devices.
- Sluggish and inconsistent operation of air valves and cylinders.
- Malfunction and high maintenance of control instruments and air logic devices.
- Product spoilage by spotting in paint and other types of spraying.



EFFECTS OF WATER CONTAMINATION

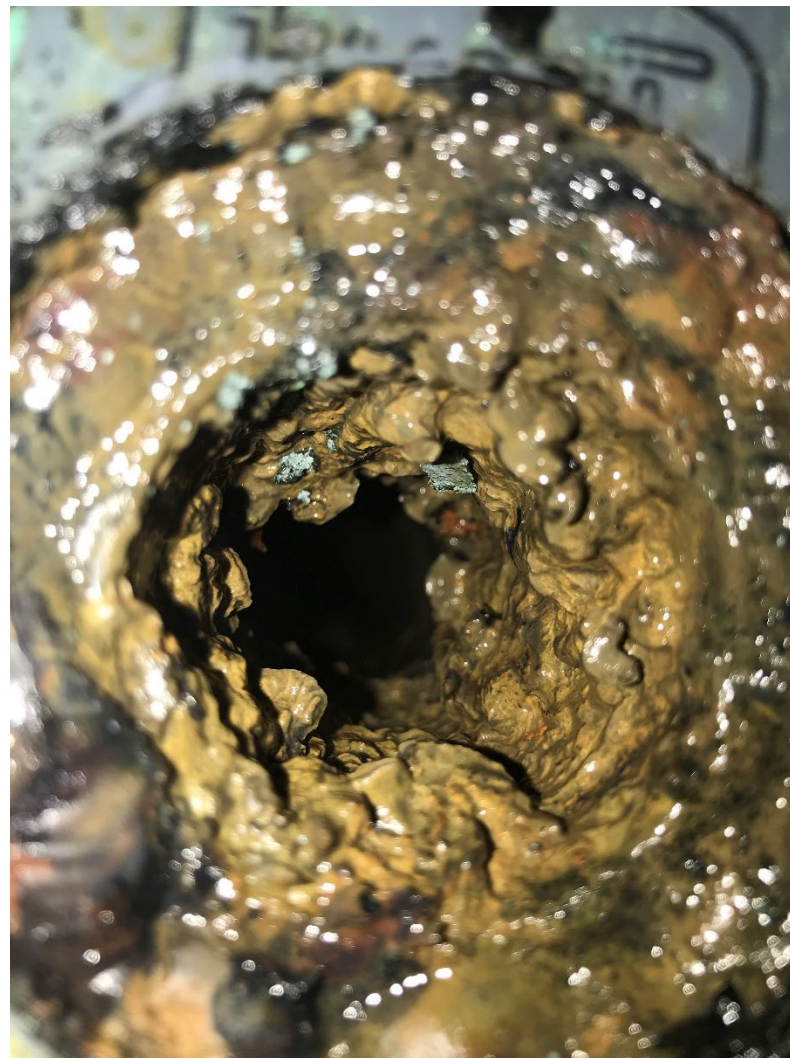

Wet Compressed Air

- All atmospheric air contains a certain quantity of water vapor which is mixed with other gases, such as nitrogen, oxygen and carbon monoxide.
 - This water vapor is drawn into the air compressor with the incoming air during the compression cycle.
 - Water is present in the air which is drawn into the compressor.
 - The water is gaseous – invisible and completely mixed with the air.
 - The exact amount of water is called the “humidity” of the air.

Definitions

■ **Relative Humidity**

- The amount of water vapor present in air expressed as a percentage of the amount needed for saturation at the same temperature.
- Hot air can hold more water (as vapor) than cold air.
 - Just a 20 degree increase in saturated air temperature allows twice the moisture to be held in vapor form.

■ **Dewpoint**

- The dew point is the temperature to which air must be cooled to become saturated with water vapor.
- When further cooled, the water vapor will condense to form liquid water.

Definitions

- **Pressure Dewpoint (PDP)**

- This refers to the temperature of gases subjected to a pressure that exceeds the normal atmospheric pressure level.
- This is typically what we are concerned with in any compressed air system and is relevant to operators seeking to protect sensitive equipment from the damaging effects of accumulated moisture.

- **Atmospheric Dewpoint**

- The atmospheric dew point is the temperature at which the water vapor content of air reaches a saturation point without the influence of external pressure.
- The atmospheric dew point temperature is measured under normal atmospheric pressure conditions.
- Atmospheric dew point is frequently employed by pilots and meteorologists to forecast weather patterns.

So How Do I Measure My Dewpoint?



- Always choose a Dew Point Sensor with multiple outputs, alarm LED, and built-in autocalibration.
- Some sensors are for Extreme Dry Air is for measuring dewpoints as low as (-100°C) -148°F
- Protect your dew point sensor from fouling and failure by using a sampling block, e.g., for protection against a high process temperature, against water spikes, and for ease of servicing

So How Do I Measure My Dewpoint?



- Some handheld Dewpoint monitors have datalogging capabilities enable enhancing industrial process efficiency by monitoring process conditions during the needed time period.
- Spot-checking helps to ensure that process conditions are within the required range to produce consistent and high-quality products.

So How Do I Measure My Dewpoint?



- Maintaining the dew point of your air or gas system will prolong the lifetime of your equipment and reduce maintenance costs.
- For dew points related to production processes, guarding the dew point is critical for the end-product and key in preventing costly production losses.
- Permanent monitoring enables you to detect and prevent problems quickly and may provide visibility that a change in dew point is capacity or maintenance related.

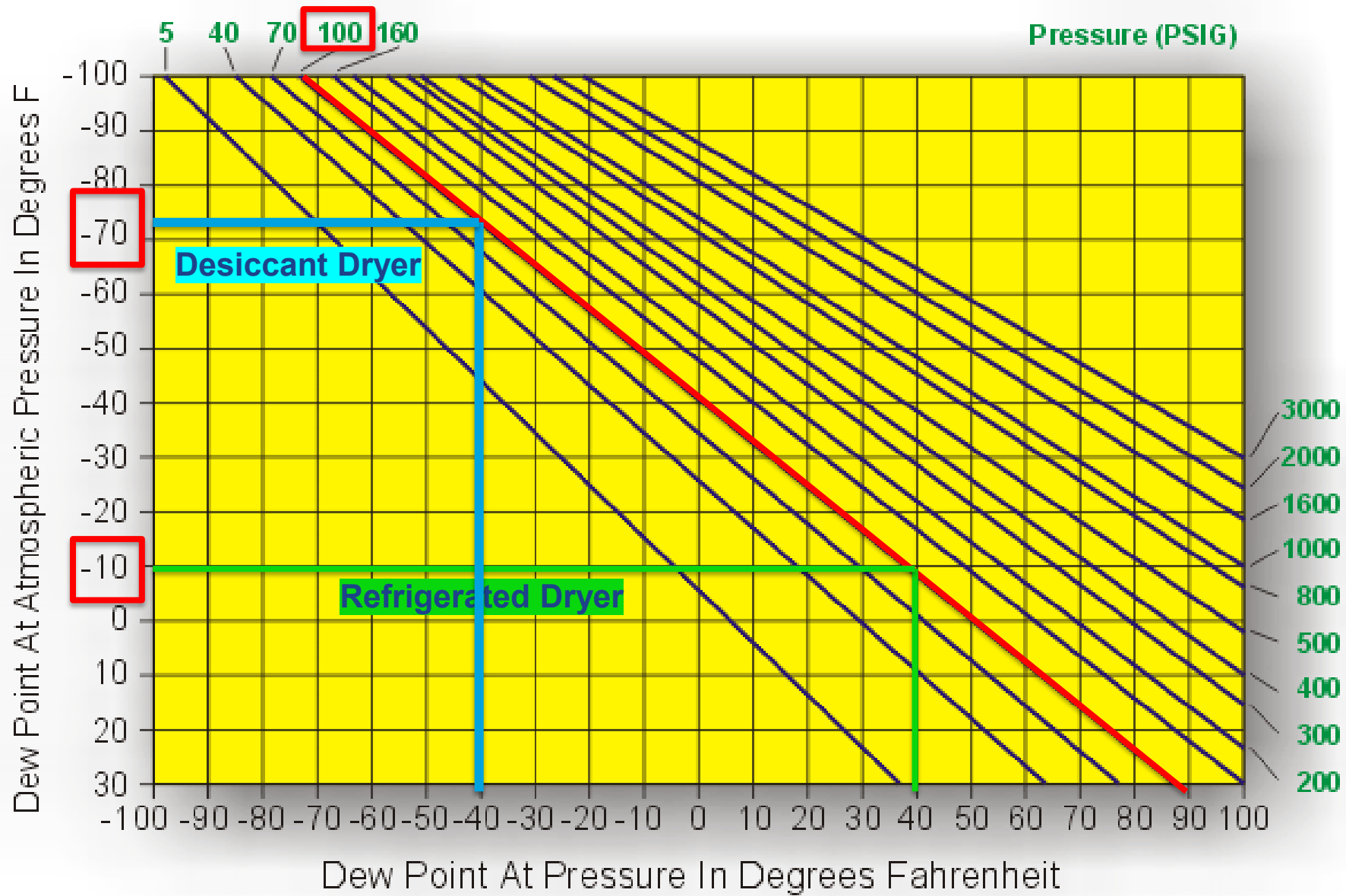

Moisture Content

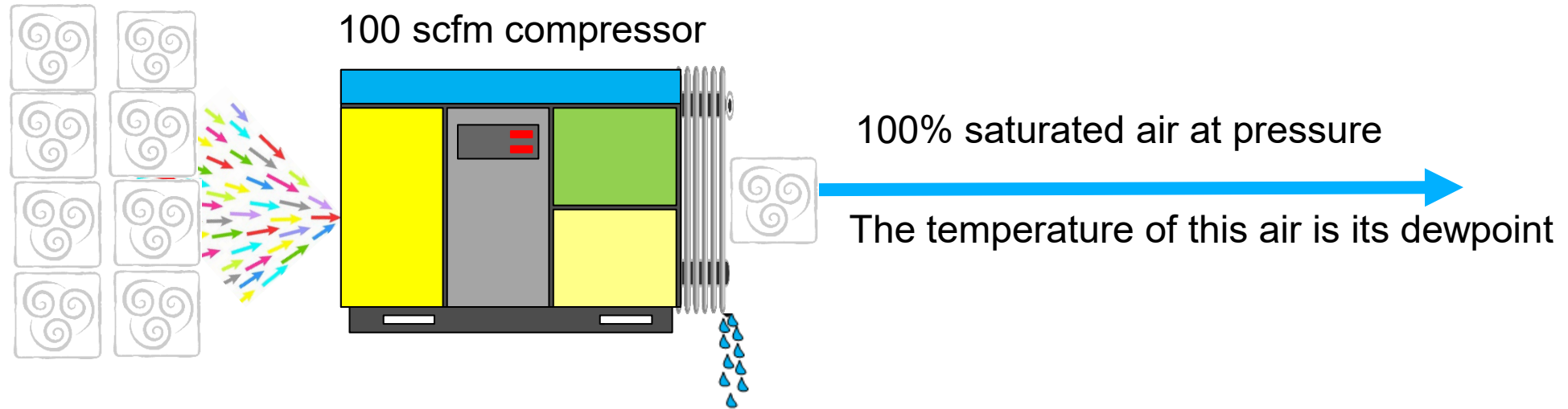

- 7.8 cubic feet of air is drawn in and compressed to 100 psig and subsequently cooled in an aftercooler.
- The increased temperature of the compressed air increases its vapor holding capacity which, in turn, reduces the relative humidity of the air because the actual water vapor content has remained constant.
- The aftercooler can remove a significant proportion of the water vapor (up to 75%) from the air through the principle of condensation. When leaving the aftercooler, the compressed air is saturated - any further cooling of the air will result in condensation.
- When air is 100% saturated, its temperature equals its dewpoint.

Moisture Content

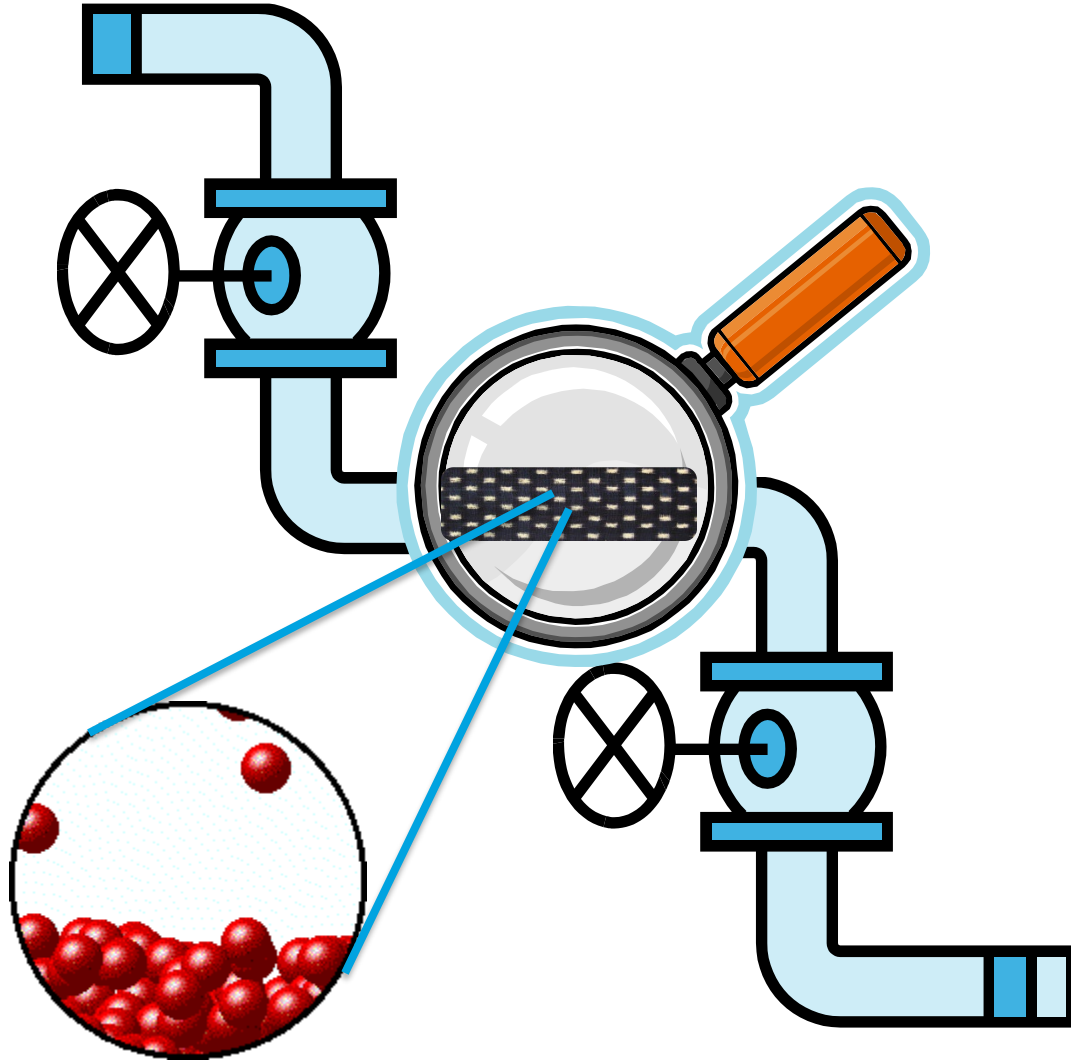

- Vapor Pressure measurements are the basis for all dew point calculations.
- These measurements are then converted to GRAINS PER CUBIC FOOT for each temperature.
- They represent the specific amount of moisture vapor which is contained in a cubic foot of saturated air.

Moisture Content

- 7000 Grains = 1 pound or 1 pint of water



Moisture Content during a 40 HOUR WEEK

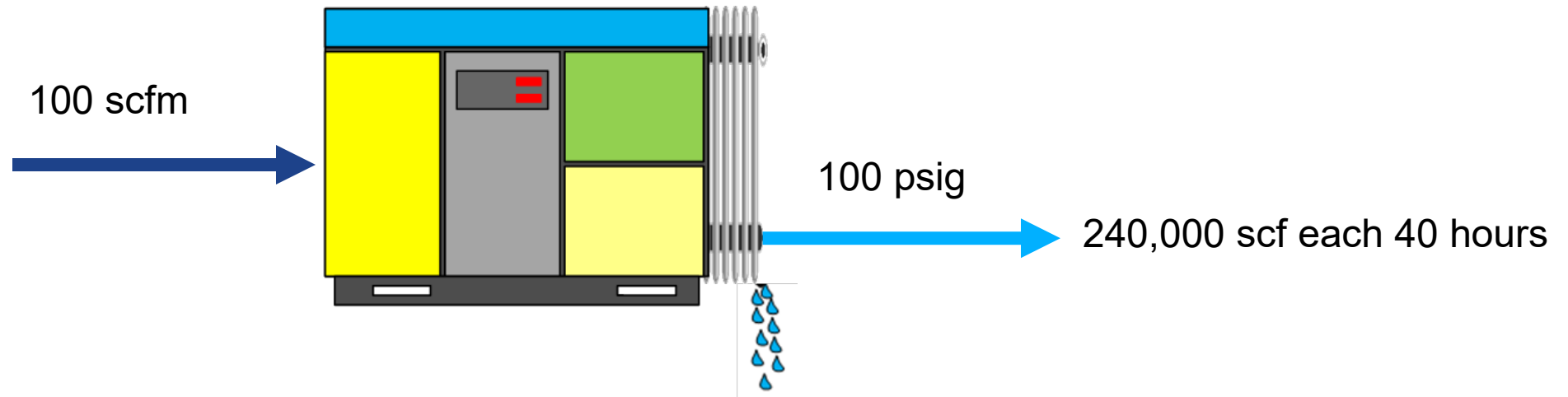

- Typical 25 hp compressor produces about 100 SCFM (Standard Cubic Feet Per Minute) at 100 psig.
- During a 40-hour week the compressor would discharge approximately 240,000 SCF into the plant piping system.
- $100 \text{ standard cubic feet/min} \times 60 \text{ minutes} \times 40 \text{ hours} = 240,000 \text{ scf}$

Moisture Content

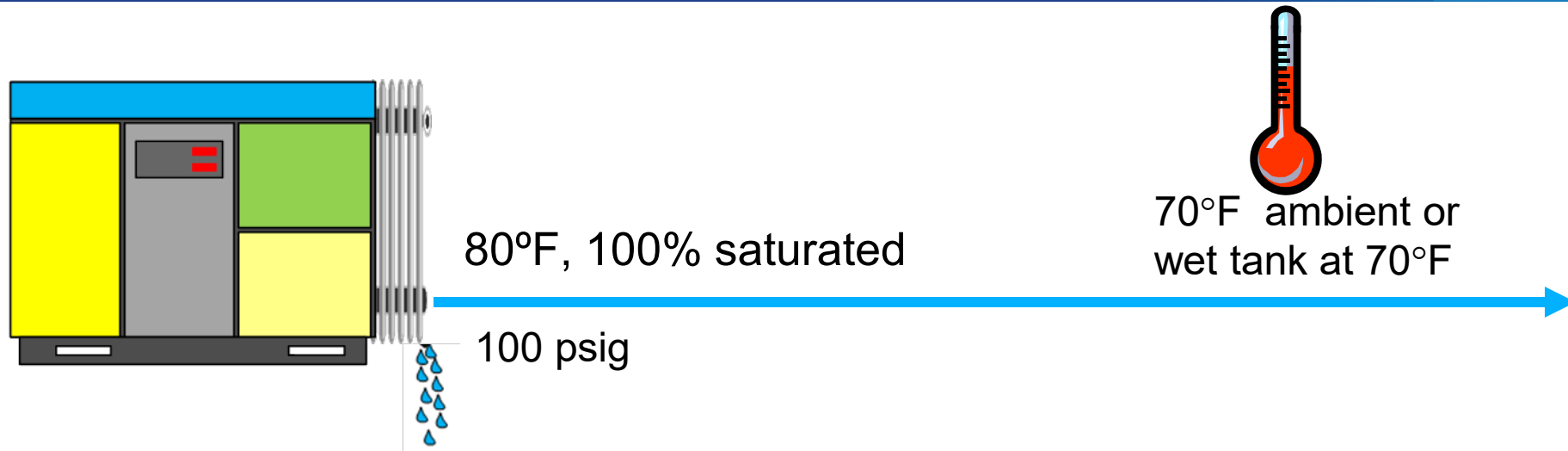

- Assume at the aftercooler outlet, the air is 80°F and saturated.
- Each scf contains 1.42 grains of moisture vapor at 80°F.
- The air surrounding the airlines is 70°F.
- Is this 10°F reduction in temperature enough to cause appreciable condensation ??

MOISTURE CONTENT

- At 80°F there is 1.42 grains per standard cubic foot.
- At 70°F a standard cubic foot of free air will still hold 1.03 grains of moisture vapor at 100% relative humidity.
- Making a difference of .39 grains per cubic foot.
- Multiply this by 240,000 standard cubic feet/week.

EQUALS 93,600 GRAINS OF MOISTURE CONDENSING IN ONE WEEK BECAUSE OF A 10 DEGREE REDUCTION IN TEMPERATURE!!

Moisture Content

- Assume compressed air leaves the compressor aftercooler at 80°F. Flow from the compressor is 100 scfm at 100 psig. Compression ratio is $114.7/14.7 = 7.8$
- Water vapor content per ft³ at 80°F and 100 psig = 10.93 grains (see chart).
- Water vapor content per ft³ at 70°F (the wet tank temperature or piping) = 7.98 grains. (see chart)
- $10.93 - 7.98 = 2.95$ grains condensing for each 7.8 ft³ of free air delivered to the system, therefore $2.95 \div 7.8 = .39$ grains condensing per ft³.
- Multiply this by 240,000 standard cubic feet/week
- Equals 93,600 grains of moisture condensing in one week because of a 10-degree reduction in temperature!!
- 93,600 divided by 7000 equals 13.4 pounds or 13 pints

Temperatures and Percentages of Saturation

Temp °F	RELATIVE HUMIDITY										Temp °F
	10%	20%	30%	40%	50%	60%	70%	80%	90%	100%	
-10	.028	.057	.086	.114	.142	.171	.200	.228	.256	.285	-10
0	.048	.096	.144	.192	.240	.289	.337	.385	.433	.481	0
10	.078	.155	.233	.310	.388	.466	.543	.621	.698	.776	10
20	.124	.247	.370	.494	.618	.741	.864	.988	1.110	1.240	20
32	.211	.422	.634	.845	1.060	1.270	1.480	1.690	1.900	2.110	32
35	.237	.473	.710	.946	1.180	1.420	1.660	1.890	2.13	2.370	35
40	.285	.570	.855	1.140	1.420	1.710	1.990	2.280	2.560	2.850	40
45	.341	.683	1.020	1.370	1.710	2.050	2.390	2.730	3.070	3.410	45
50	.408	.815	1.220	1.630	2.040	2.450	2.850	3.260	3.670	4.080	50
55	.485	.970	1.460	1.940	2.420	2.910	3.390	3.880	4.360	4.850	55
60	.574	1.150	1.720	2.300	2.870	3.450	4.020	4.600	5.170	5.750	60
65	.678	1.360	2.030	2.710	3.390	4.070	4.750	5.420	6.100	6.780	65
70	.798	1.600	2.390	3.190	3.990	4.790	5.590	6.380	7.180	7.980	70
75	.936	1.870	2.810	3.740	4.680	5.620	6.550	7.490	8.420	9.360	75
80	1.09	2.19	3.28	4.37	5.47	6.56	7.65	8.75	9.84	10.93	80
85	1.27	2.54	3.81	5.08	6.35	7.62	8.89	10.16	11.43	12.73	85
90	1.48	2.96	4.44	5.92	7.40	8.87	10.35	11.83	13.31	14.78	90
95	1.72	3.44	5.16	6.88	8.60	10.32	12.04	13.76	15.48	17.15	95
100	1.98	3.95	5.93	7.91	9.88	11.86	13.84	15.81	17.79	19.77	100
110	2.63	5.26	7.89	10.52	13.15	15.78	18.41	21.04	23.67	26.33	110
120	3.45	6.90	10.35	13.80	17.25	20.70	24.15	27.60	31.05	34.48	120
130	4.44	8.88	13.32	17.76	22.20	26.64	31.08	35.52	39.96	44.42	130
140	5.68	11.36	17.04	22.72	28.40	34.08	39.76	45.44	51.12	56.82	140
150	7.19	14.38	21.57	28.76	35.95	43.14	50.33	57.52	64.71	71.96	150
160	9.04	18.08	27.12	36.16	45.20	54.24	63.28	72.32	81.36	90.44	160
170	11.26	22.52	33.78	45.04	56.30	67.56	78.82	90.08	101.34	112.63	170
180	13.92	27.84	41.76	55.68	69.60	83.52	97.44	111.36	125.28	139.23	180

Saturation Column



MOISTURE CONTENT

- 7000 grains of water equals one pound or one pint
- 93,600 divided by 7000 equals 13.4 pounds or 13 pints

Just a 10° F drop in temperature will allow 13 pints (1.625 gallons) of water to condense into the piping system in 40 hours!

Even with this amount of water removed, the RH is still 100% and the dew point down stream of the aftercooler is now 70° F

Is the Separator and Trap Even Working?



Is the Separator and Trap Even Working?



Water Contamination Inside Pipe



Moisture Content

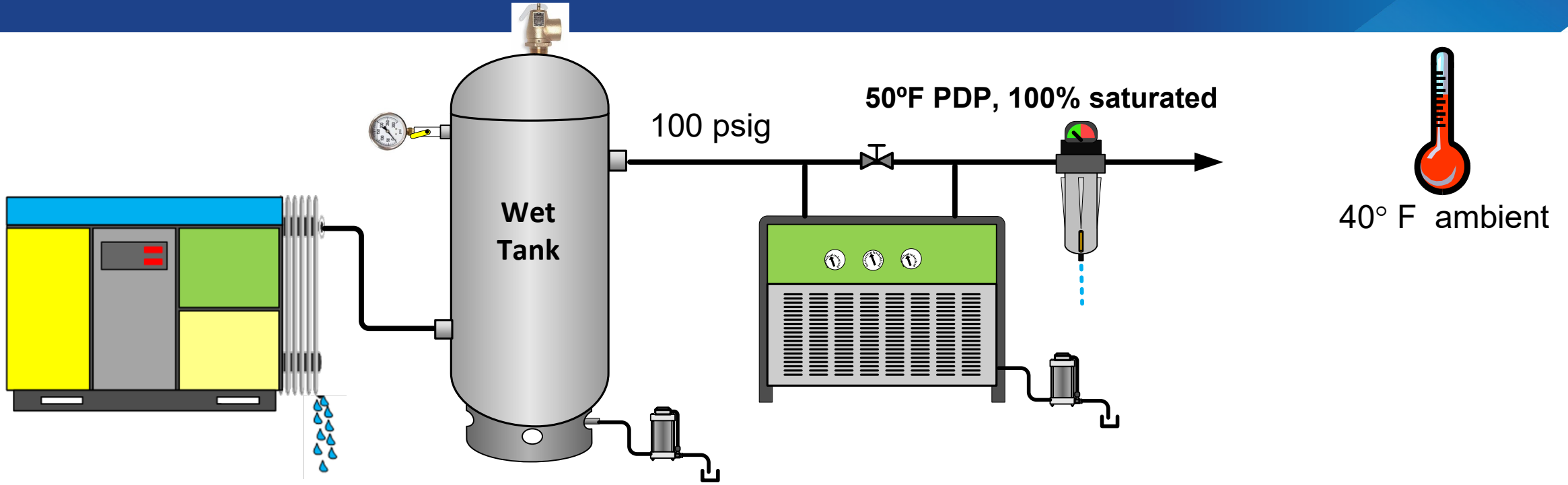

- The dryer has chilled the air to 50°F which creates a 50°F PDP.
- Each scf contains .523 grains of moisture vapor at 50°F.
- The air surrounding the dryer outlet piping is 40°F.
- Is this 10°F reduction in temperature enough to cause appreciable condensation ??

MOISTURE CONTENT

- At 50°F there is .523 grains per standard cubic foot.
- At 40°F a standard cubic foot of free air will still hold .3654 grains of moisture vapor at 100% relative humidity.
- Making a difference of .1576 grains per cubic foot.
- Multiply this by 240,000 standard cubic feet/week.

EQUALS 37,824 GRAINS OF MOISTURE CONDENSING IN ONE WEEK BECAUSE OF A 10 DEGREE REDUCTION IN TEMPERATURE!!

MOISTURE CONTENT

- 7000 grains of water equals one pound or one pint
- 37,824 divided by 7000 equals 5.4 pounds or 5.4 pints (.675 gallons)

Just a 10° F drop in temperature below the dewpoint will allow 5.4 pints (.675 gallons) of water to condense into the piping system in 40 hours!

Even with this amount of water removed, the RH is still 100% and the dew point down stream of the aftercooler is now 40° F

The Aftercooler Must Work!

Capacity	100	cfm
	102	psi (g)
	80	°F
Air Usage	100	cfm

Water Remaining in Compressed Air

Imperial Units

Drying Method	Dewpoint	Gallons Week	Gallons Annum
No Treatment	127°F	76.4	3975.0
After Cooler	98°F	32.6	1693.0
Deliquescent	87°F	23.7	1232.8
Refrigerant	37°F	4.3	225.9
Desiccant	-40°F	0.09	4.8

Metric Units

Drying Method	Dewpoint	Litres Week	Litres Annum
No Treatment	53°C	347.5	18068.2
After Cooler	37°C	148.0	7695.4
Deliquescent	26°C	107.8	5603.7
Refrigerant	3°C	19.7	1026.6
Desiccant	-40°C	0.4	22.0

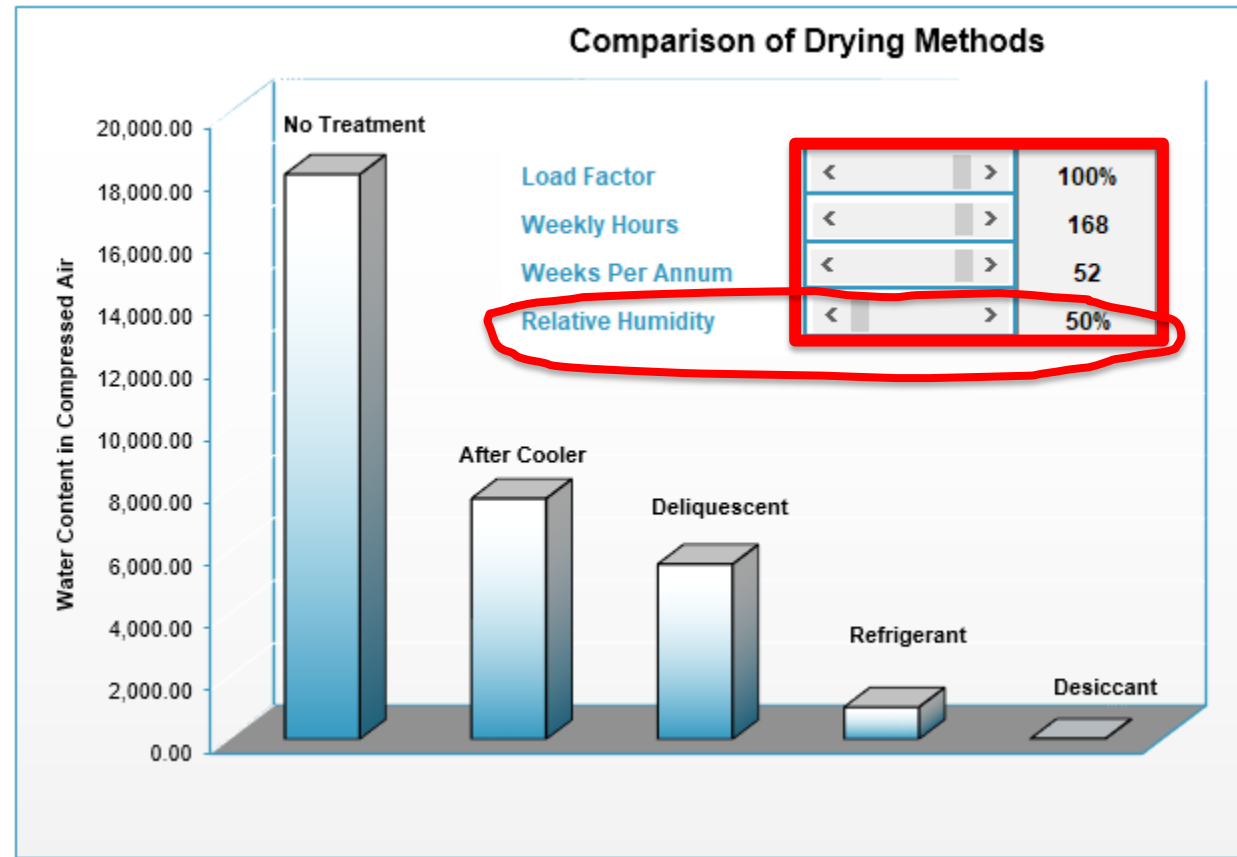

The Aftercooler Must Work!

Capacity	100	cfm
	102	psi (g)
	80	°F
Air Usage	100	cfm

Water Remaining in Compressed Air

Imperial Units

Drying Method	Dewpoint	Gallons Week	Gallons Annum
No Treatment	154°F	145.2	7552.5
After Cooler	98°F	32.6	1693.0
Deliquescent	87°F	23.7	1232.8
Refrigerant	37°F	4.3	225.9
Desiccant	-40°F	0.09	4.8

Metric Units

Drying Method	Dewpoint	Litres Week	Litres Annum
No Treatment	68°C	660.2	34329.5
After Cooler	37°C	148.0	7695.4
Deliquescent	26°C	107.8	5603.7
Refrigerant	3°C	19.7	1026.6
Desiccant	-40°C	0.4	22.0

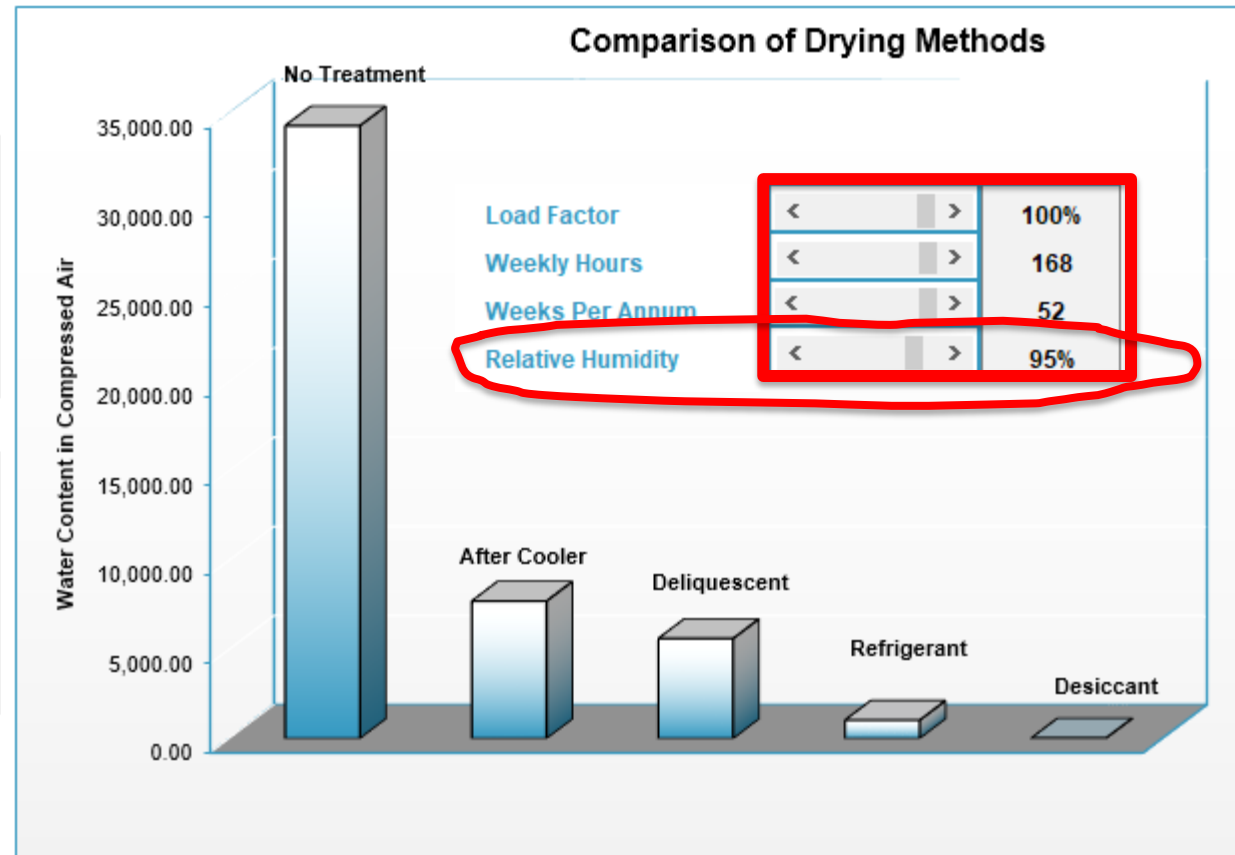

Water Basics

- Water will be carried past drain locations if the pipe diameter is too small.
 - The key is to use a large enough pipe diameter to slow the air velocity below 20 fps, which makes it easier for liquids to drop out of the air flow.
- Always use level activated drains at condensation drain locations.
 - This provides the best opportunity for immediate and continuous removal of liquids.

Water Basics

- Water vapor will always move from an area of high relative humidity to an area of low relative humidity, regardless of the direction of air flow.
 - Yes, an air leak can allow water vapor into your piping.
- Liquid water will always drain down by gravity, regardless of the direction of air flow.
 - This sounds like common sense, but many people forget this when evaluating or installing piping and draining systems.
- Liquid water left to stand in air receivers, filter housings, etc., will evaporate into the dry air.
 - This will raise the relative humidity and pressure dew point within the system, and carry liquids throughout the system

Deterioration of Dew Point Through Compressed Air Leaks

- Small pinhole leaks that develop in compressed air pipelines allow moisture to enter and deteriorate the dew point.
- As compressed air exits through any leak, rapid expansion takes place, which absorbs heat from any source and chills the surface of the pipe near the leak.

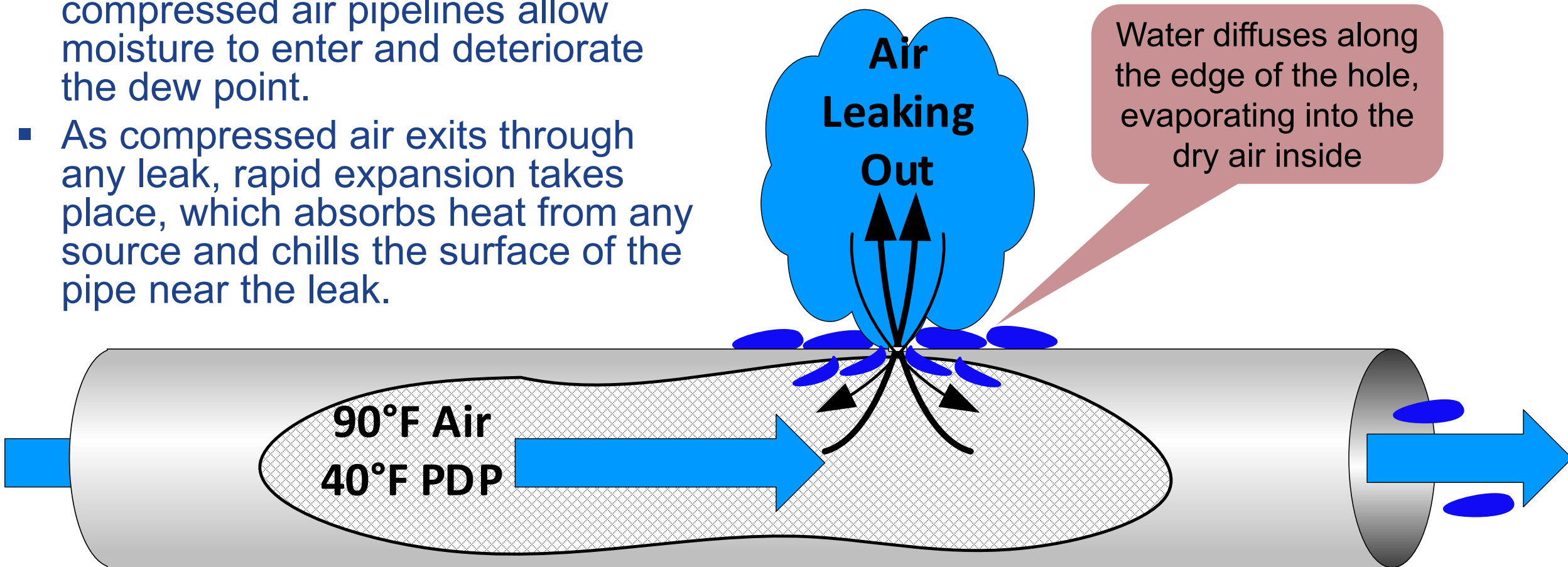

Deterioration of Dew Point Through Compressed Air Leaks (Ficks Law)

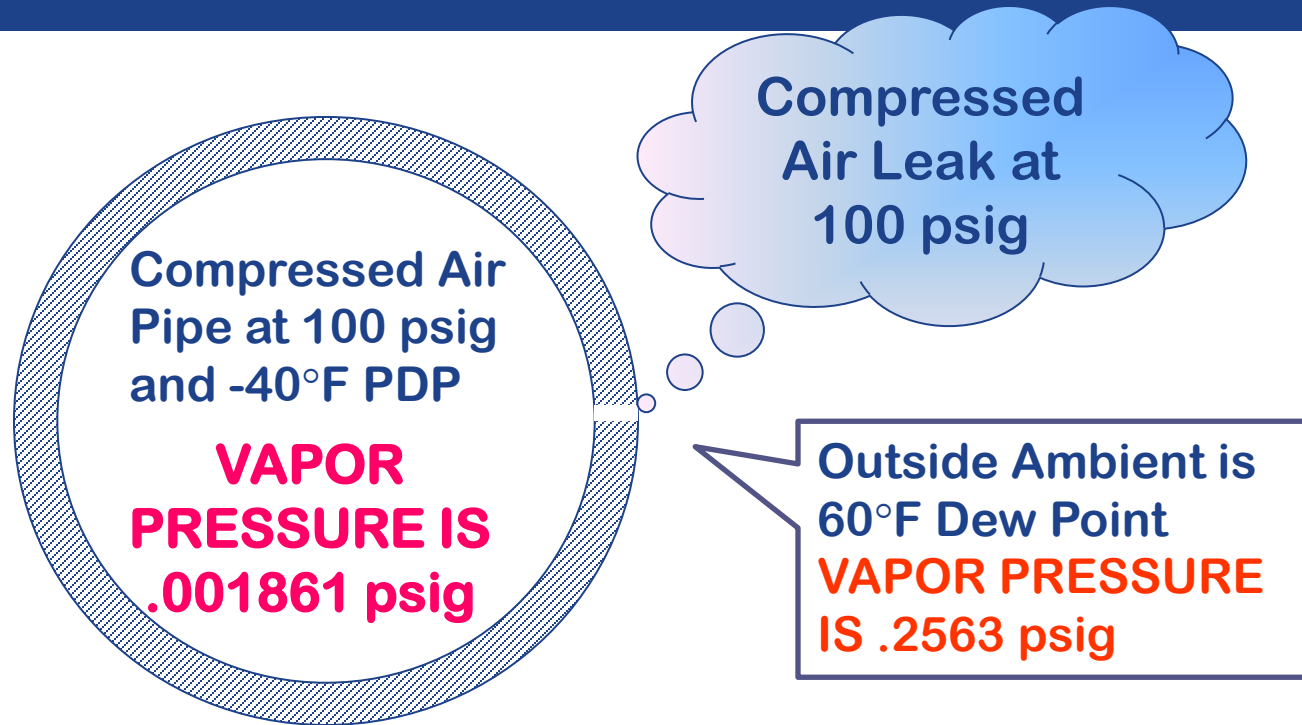

- Water and air will always seek to reach equilibrium.
- Any dryer will create an unstable gas that will aggressively seek water vapor.
- If the entire compressed air supply is dried to -20 F or below, the piping must be completely free of any leaks, or the dewpoint will degrade.
- Maintaining such a dry air condition would involve welding every connection throughout the entire pipeline.

Vapor Pressure Differential

Ratio (VPDR) for -40°F is $.2563/.001861 = 138$

Moisture Driving Force Into Compressed Air is 138 Times!

At a -100°F VPDR it would be 11,192!

Wet Compressed Air

- The tough question you must answer is which type of dryer is the best choice for your application.

Specifying the Right Dryer

- In specifying the right dryer for a compressed air installation, keep the following information in mind
 - Do not over specify - Drying the entire compressed air supply in a factory to dewpoints less than -40°F (-40°C) is wasteful.
 - It is more sensible to subdivide the compressed air supply by application, treating each end use point as needed to provide appropriately dry air for the downstream application served.
 - Do not underspecify - Damage caused by wet air costs money in maintenance time and supplies, downtime, and lost production.

Specifying the Right Dryer



versus



- Do not dry compressed air more than is required by the application.
- Consider initial drying with a refrigerant type dryer then drying further only to meet the requirement at a specific point of use.
- Leaks in the piping can degrade the Pressure-Dewpoint.

Instrument Air

- The Specification for Instrument air quality is governed by ANSI/ISA-7.0.01-1996 "Quality Standard for Instrument Air". This specification stipulates the following:
 - **Pressure Dew Point:** "The pressure dew point as measured at the dryer outlet shall be at least 10°C (18°F) below the minimum temperature to which any part of the instrument air system is exposed. The pressure dew point shall not exceed 39°F (4°C) at line pressure".
 - **Particle Size:** "A maximum 40-micron particle size in the instrument air system is acceptable for a majority of pneumatic devices".
 - **Lubricant Content:** "The lubricant content should be as close to zero as possible and under no circumstances shall it exceed 1 ppm.
 - **Contaminants:** "Instrument air should be free of corrosive contaminants and hazardous gases which could be drawn into the instrument air supply".

Refrigerant Dryer

1. Air section (Air to Air Heat Exchanger)

- Hot wet air at the inlet is precooled
- Cold dry air is reheated when leaving the heat exchanger

2. Evaporator (Air to Refrigerant Heat Exchanger)

- Air is further cooled down by the refrigerant at low pressure.
- Typical PDP of 35°F to 39°F
- **The power requirement, including the effect of pressure drop through the dryer, is 0.80 kW/100 cfm.**

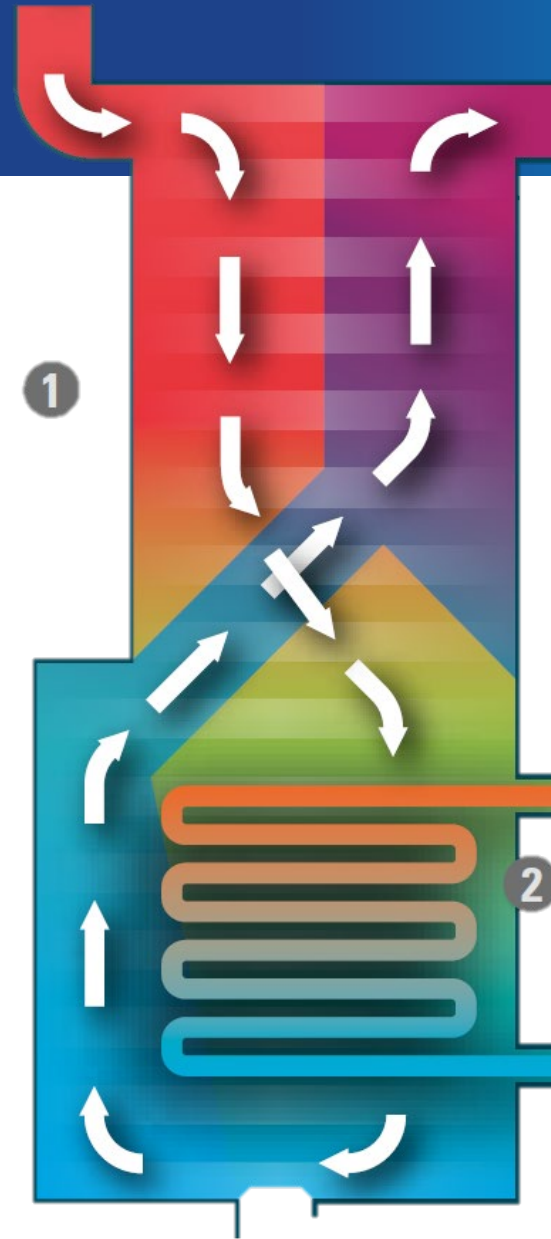

Refrigerant Dryer

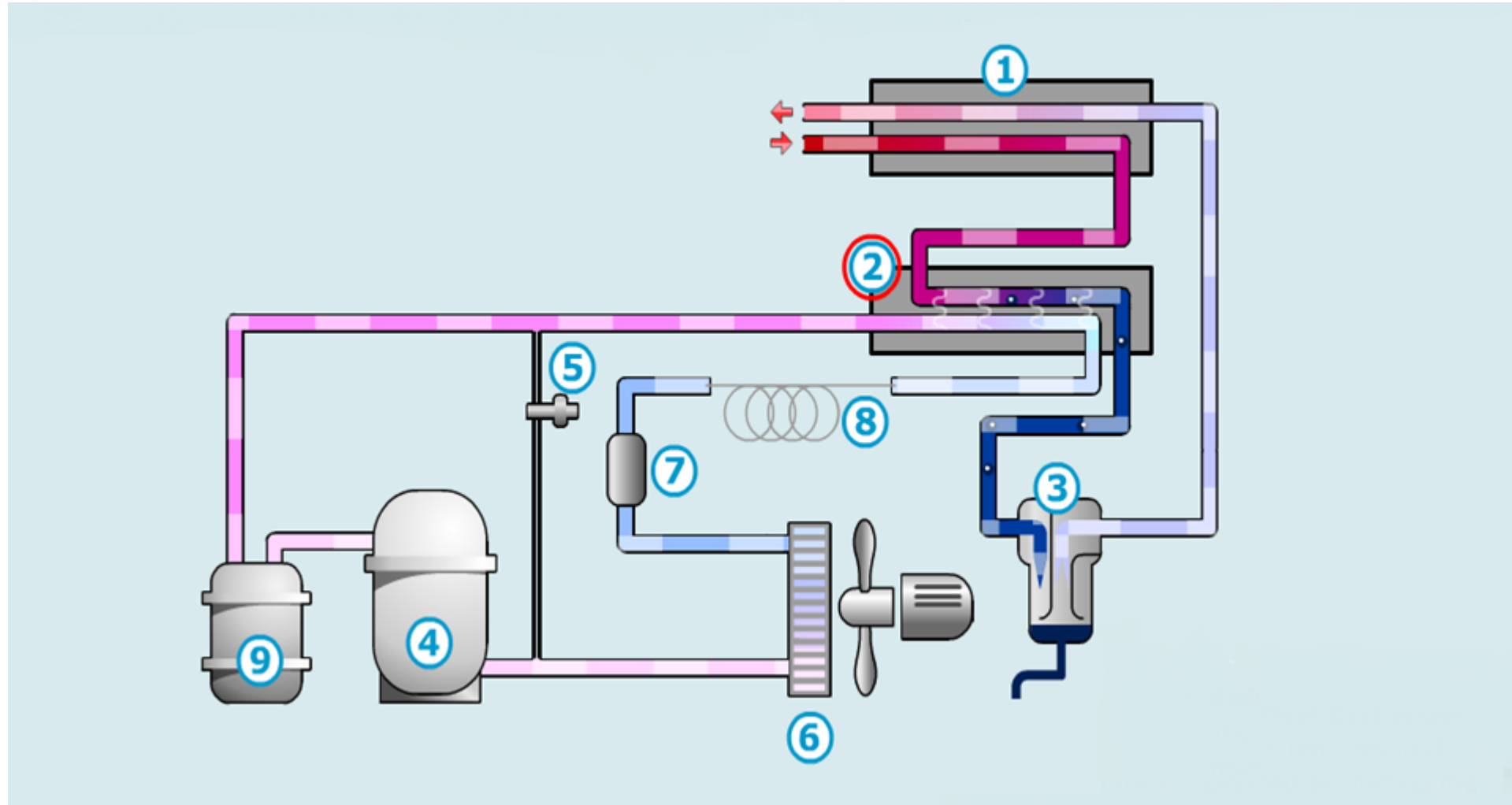

3-100 Rule

C₁ – Inlet Air Pressure Correction Factor

Pressure

(PSIG)	40	60	80	100	120	140	150	180	200
C ₁	.67	.83	.94	1.00	1.03	1.05	1.08	1.09	1.11

C₂ – Inlet Air Temperature Correction Factor

Temp ° F	60	70	80	90	100	110	120
C ₂	2.73	1.94	1.50	1.21	1.00	0.84	0.69

C₃ – Ambient Air Temperature Correction Factor (air cooled unit only)

Temp ° F	60	70	80	90	100	110
C ₃	1.34	1.24	1.15	1.07	1.00	0.91

C₄ – Pressure Dew Point Correction Factor

Temp ° F	35°F to 39°F	45°F to 50°F
C ₃	1	1.2

Approach Temperature or CTD

- Aftercooler approach temperature is 15°F
- Cooling air moving through fins is 90°F
- Compressed air leaving this aftercooler should be 105°F

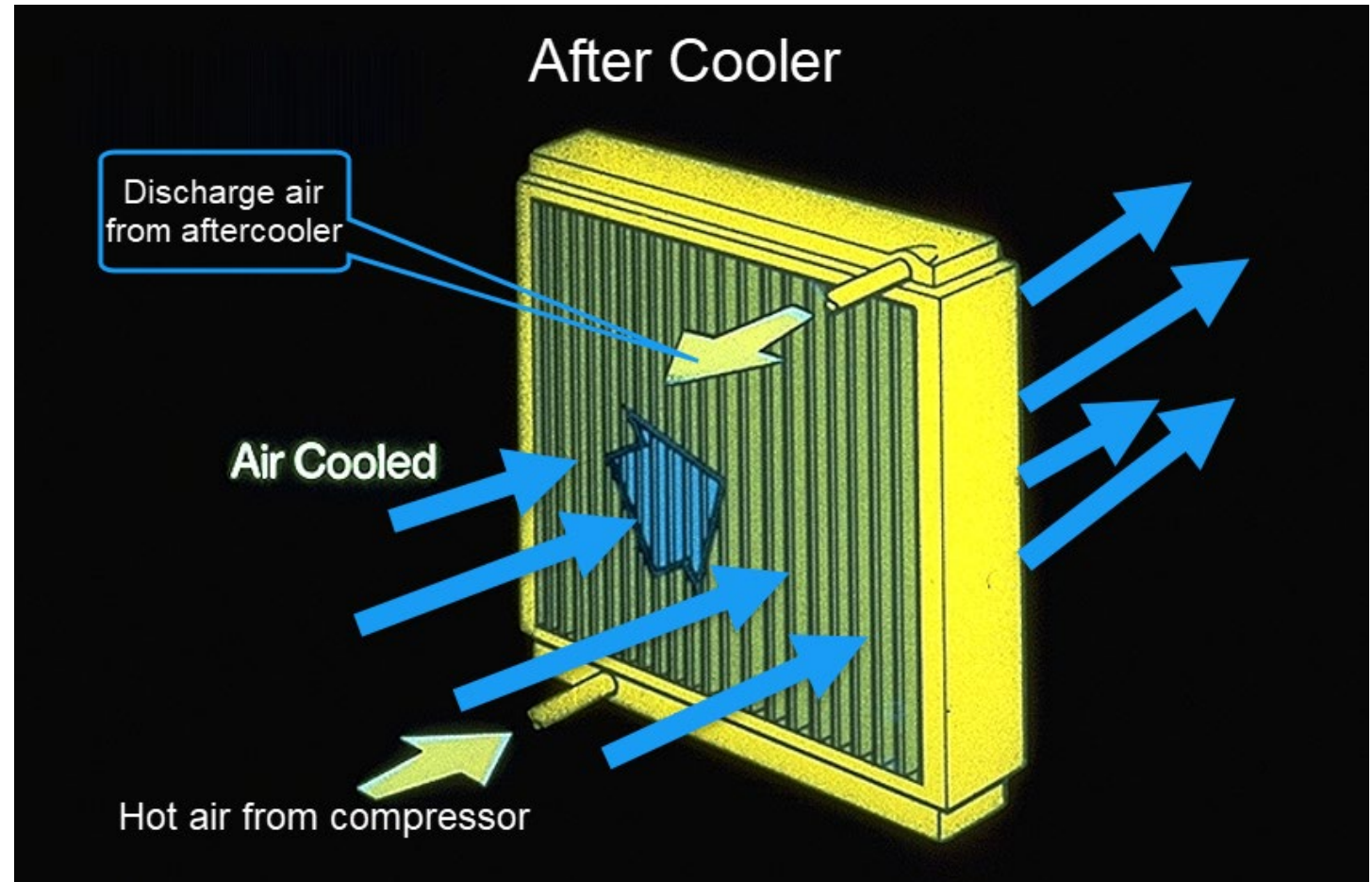

Adsorption Drying (Heatless, Heated, Blower Purge)

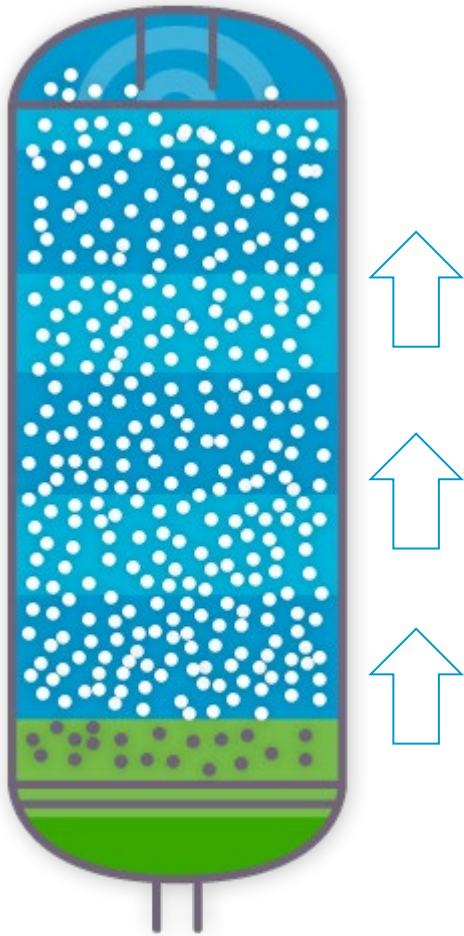

- Water vapor transfers to the desiccant because the water is more attracted to the desiccant than to the air.
- Attraction slowly decays as the desiccant gets wet.
- The beads becomes fully saturated at around 50% of the cycle time.
 - Constant dew point $-40^{\circ}\text{C}/\text{F}$ until that time
- Once saturated, the dew point degrades slowly.
- Positive dew point: hard to regenerate the desiccant.
- **The power requirement, including the effect of pressure drop through the dryer is 2.0-3.0 kW/100cfm.**

Adsorption Drying (Heatless, Heated, Blower Purge)



- These dryers use a porous desiccant that adsorbs the moisture by collecting it in its myriad pores, allowing large quantities of water to be retained by a relatively small quantity of desiccant.
 - Activated Alumina (highly porous form of aluminum oxide),
 - Silica Gel - Silicon dioxide (SiO_2), is the same material found in quartz. It is a granular amorphous form of silica, made from sodium silicate and sulfuric acid. Extremely high capacity for adsorbing water
 - Molecular Sieve (synthetic zeolite materials engineered with pores of precise and uniform structure and size)

Adsorption Dryer - Heatless

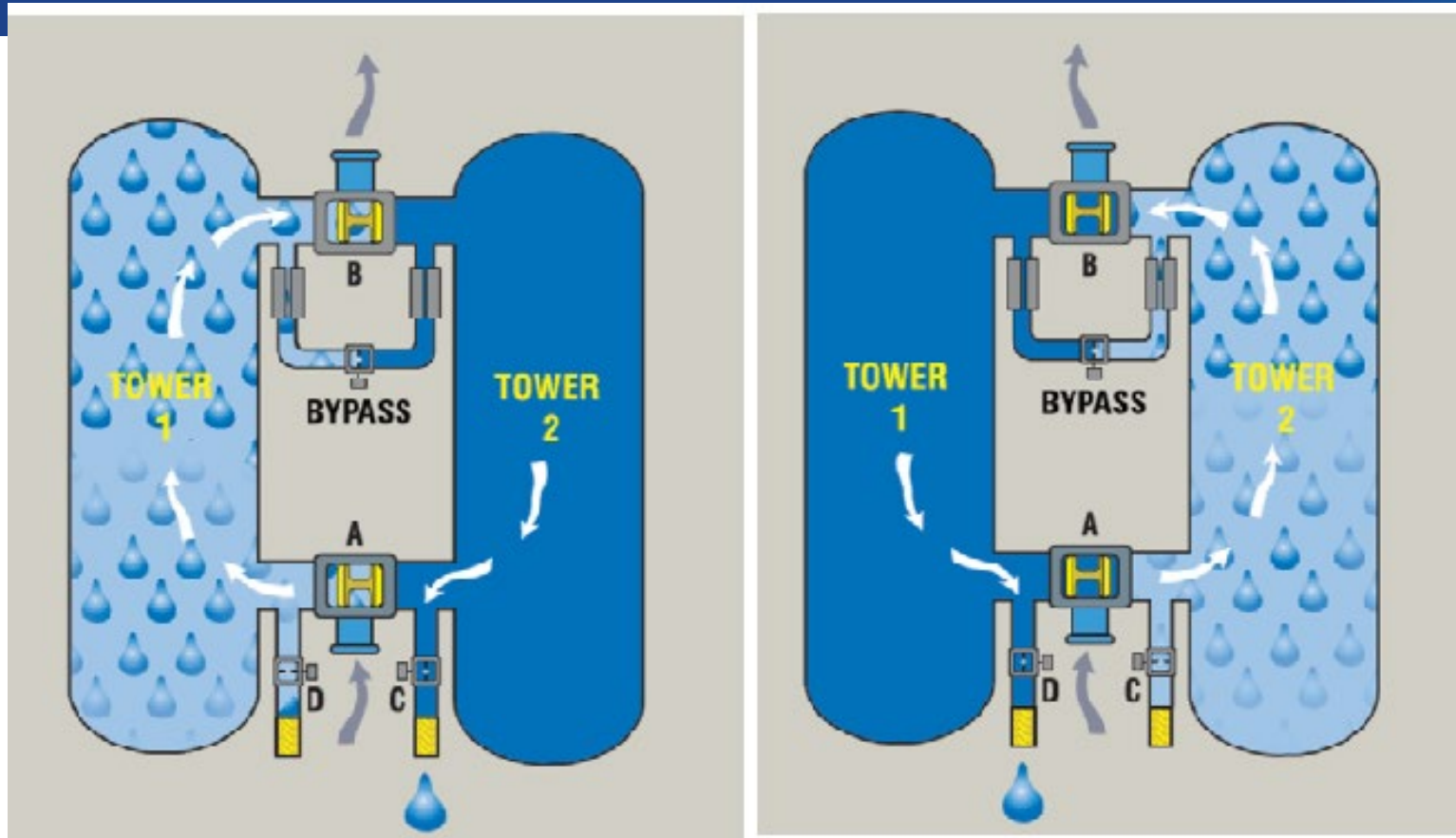

- The power requirement, including the effect of pressure drop through the dryer is 2.0-3.0 kW/100cfm.

Adsorption Drying

- Water vapor is bound by a physical process.
(this means the process of adsorption is reversible)
- All materials can adsorb and desorb water.
- One desiccant bead contains more pores than a football field contains blades of grass.
- Typical PDP is -40°F

Typical Cycle Time
of 5 to 10 minutes

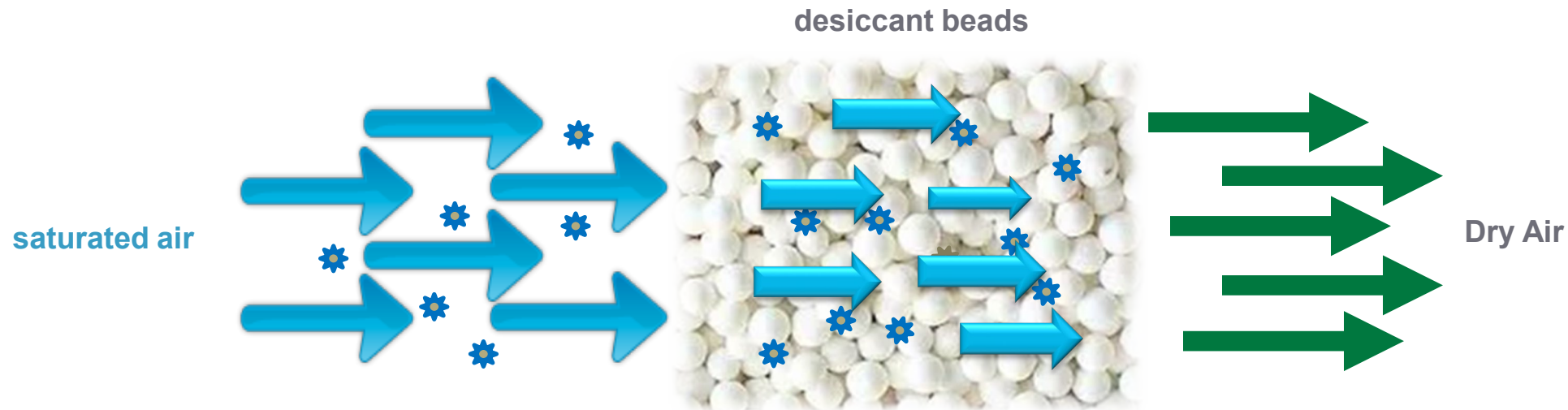

Adsorption Dryer – Heatless Regeneration

- Regeneration occurs by using 15-18 percent of the dry compressed air.
- Expanded purge air is much dryer than the desiccant.
- Water vapor is more attracted to the dry air than to the desiccant.
- Water detaches from the desiccant and moves into the dry air flow.

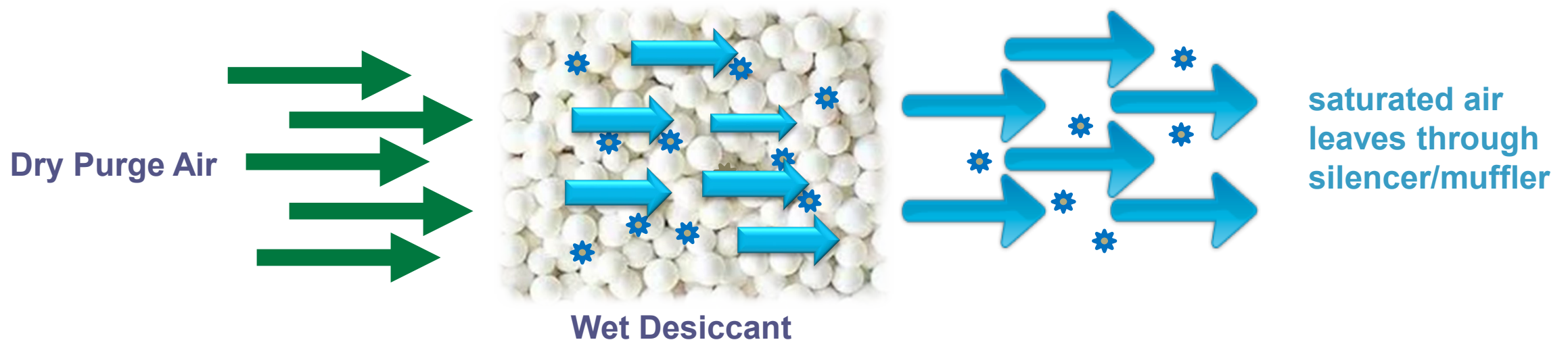

Regenerative-Desiccant Externally Heated or Blower Purge

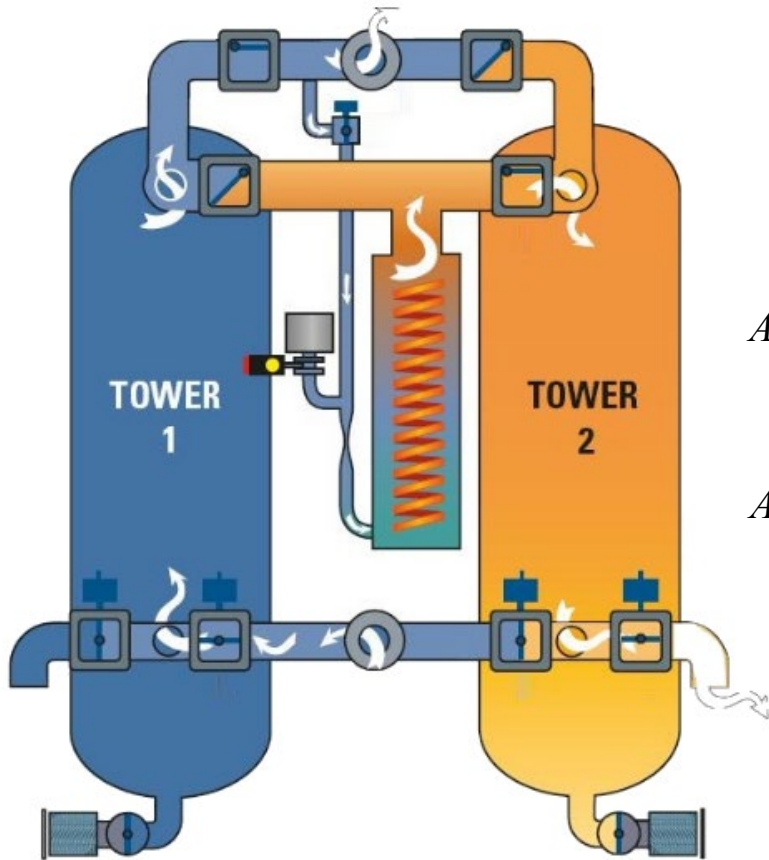

4 hours is a standard cycle: 3 hours drying, 1 hour of regeneration @ 350-400°F

$$\text{Average Purge} = \text{Peak Purge} \times \frac{\text{Peak Purge Time}}{\text{Half Cycle Time}}$$

$$\text{Average } 2\% = 8\% \times \frac{1 \text{ hour (cooling)}}{4 \text{ hours Half Cycle Time}}$$

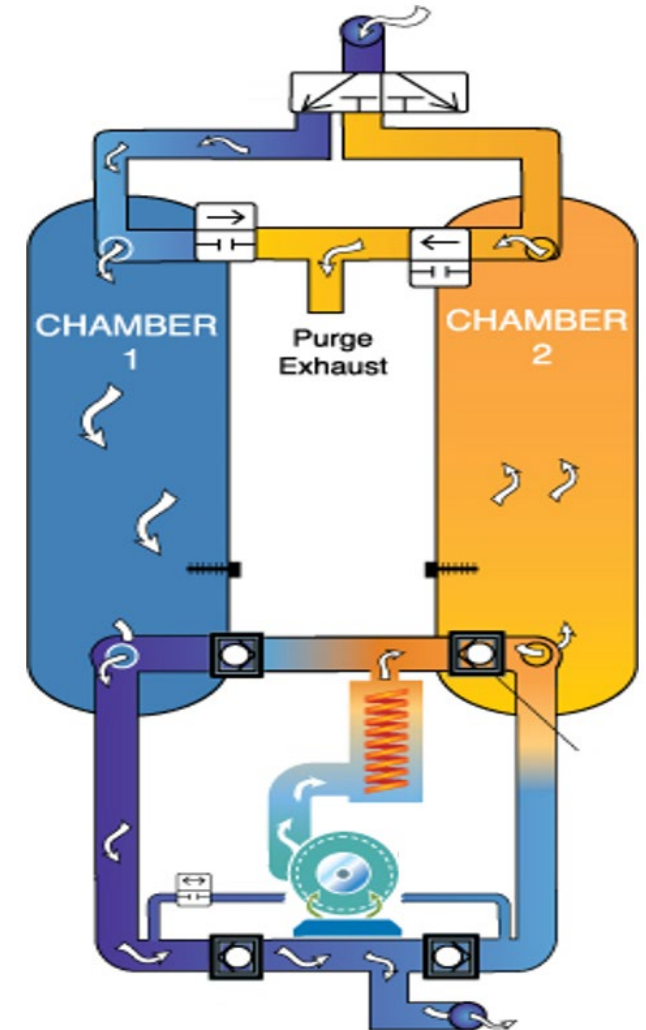

Adsorption Dryer – Heated Regeneration

- Regeneration is enhanced by adding energy (heat).
- This causes the water molecules in the desiccant beads to vibrate and move around frantically, which triggers the reverse physical action of adsorption.
- The surface tension is reduced.... and the water retaining forces – the so-called Van der Waals forces – are broken down, setting the water free in the form of vapor that we can then discharge.

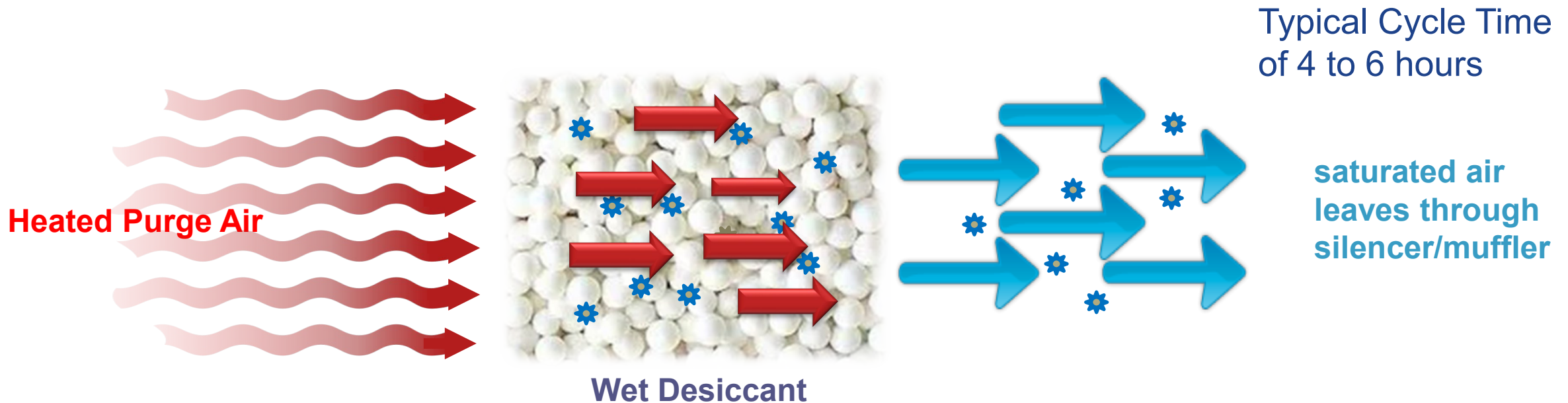

Be Aware of Purge Rates

- What does average purge rate mean?
- Heatless dryers can have a continuous 15% - 20% purge loss.
- Heated blower purge dryers might advertise 2% purge loss.
- Typically, they have a 4-hour half cycle with up to one hour of cooling using 8% purge.
- Be aware of the continuous cooling purge amount.

$$\text{Peak Purge} \times \frac{\text{Peak Purge Time}}{\text{Half cycle time}} = \text{Average Purge}$$
$$8\% \times \frac{1 \text{ Hour Cooling}}{4 \text{ Hours Halfcycle Time}} = 2\% \text{ Average Purge}$$

Heat of Compression Desiccant Type Dryer

- The heat of compression supplies the temperature differential to create the “RH” imbalance and allows the removal of the water vapor to the regenerating bed to the “purge” air stream.
- The “purge” air stream goes through the water-cooled after-cooler/separator where the moisture in the air stream is condensed to liquid and removed. The after-cooler is mounted on the dryer.
- The “purge” air stream then goes to the drying tower where all of the discharge air is dried and sent to the air system. No “purge” air is lost.

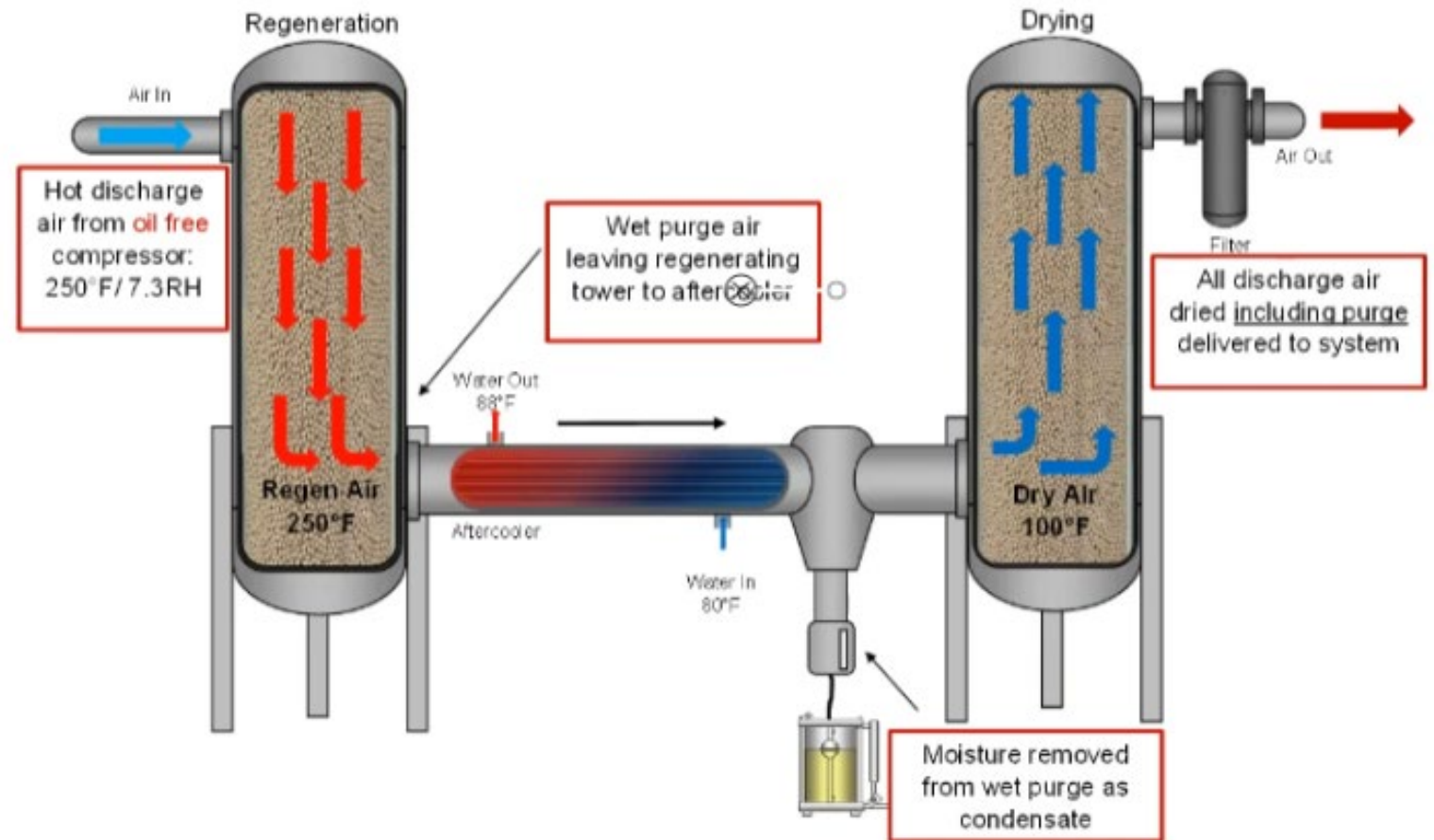

Heat of Compression Dryer

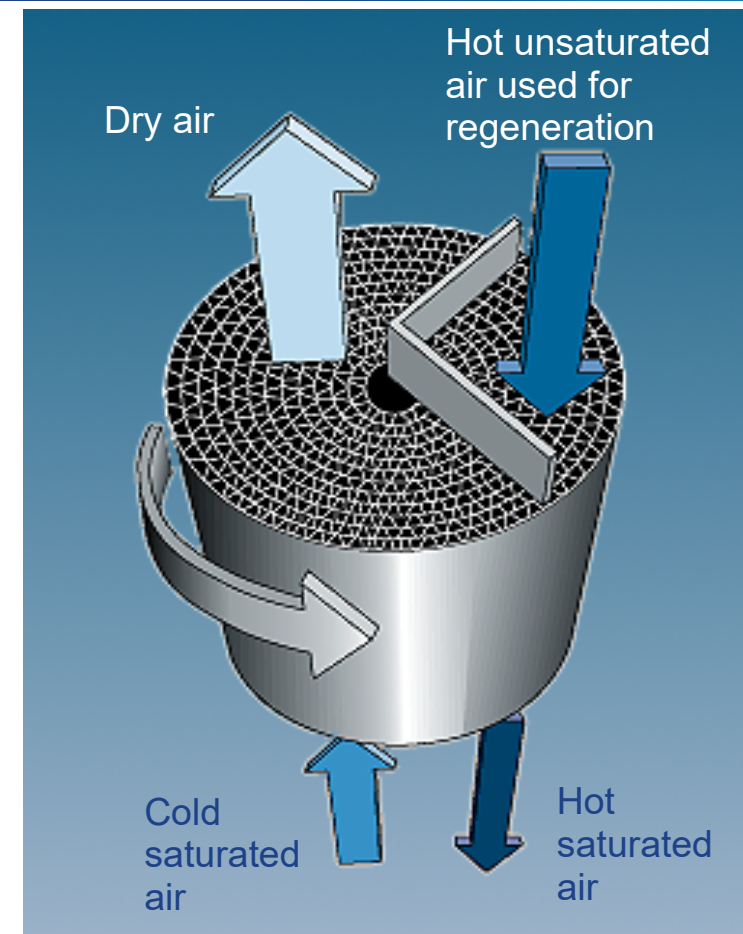
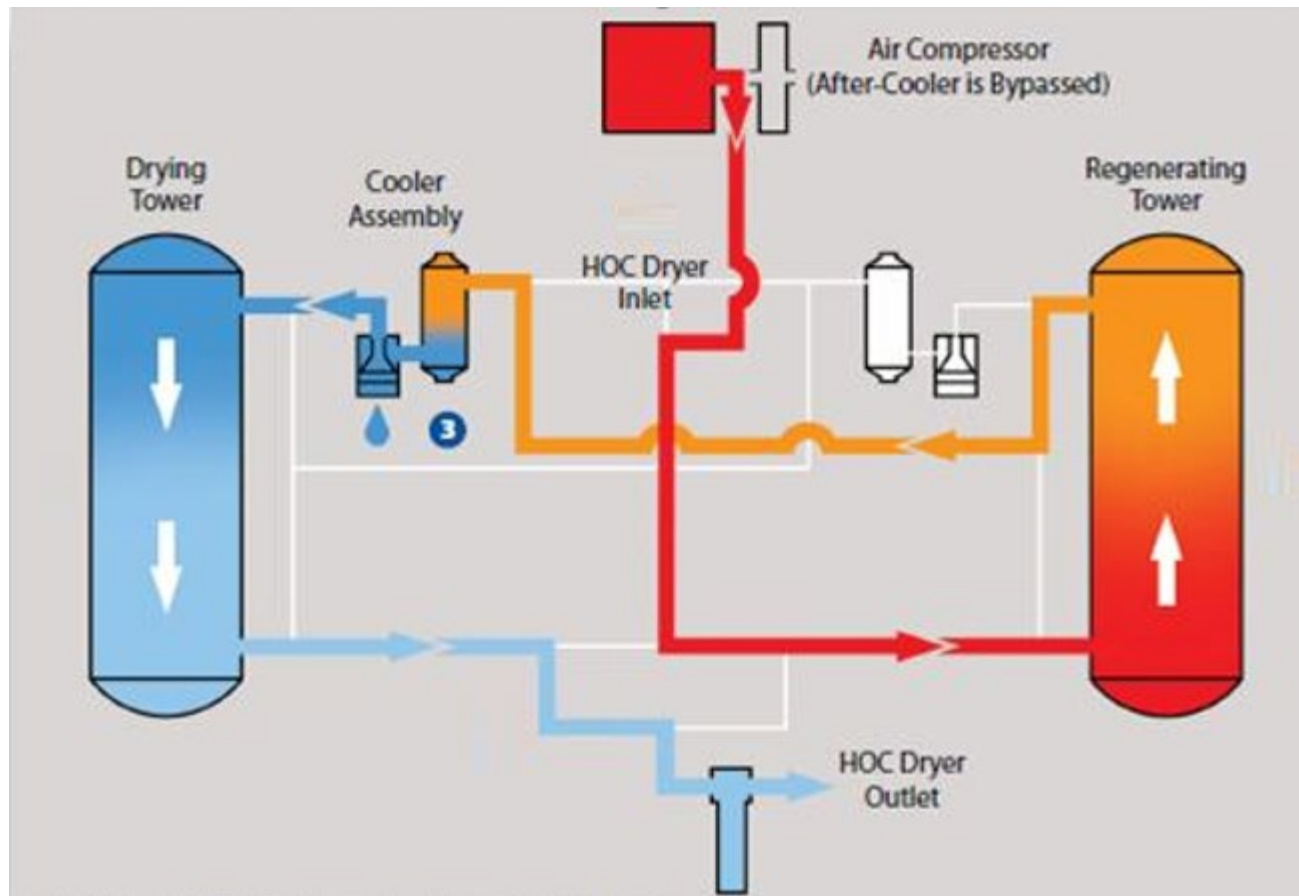

- The power requirement, including the effect of pressure drop through the dryer, is approximately **0.80 kW/100 cfm**.

Watch for Problems

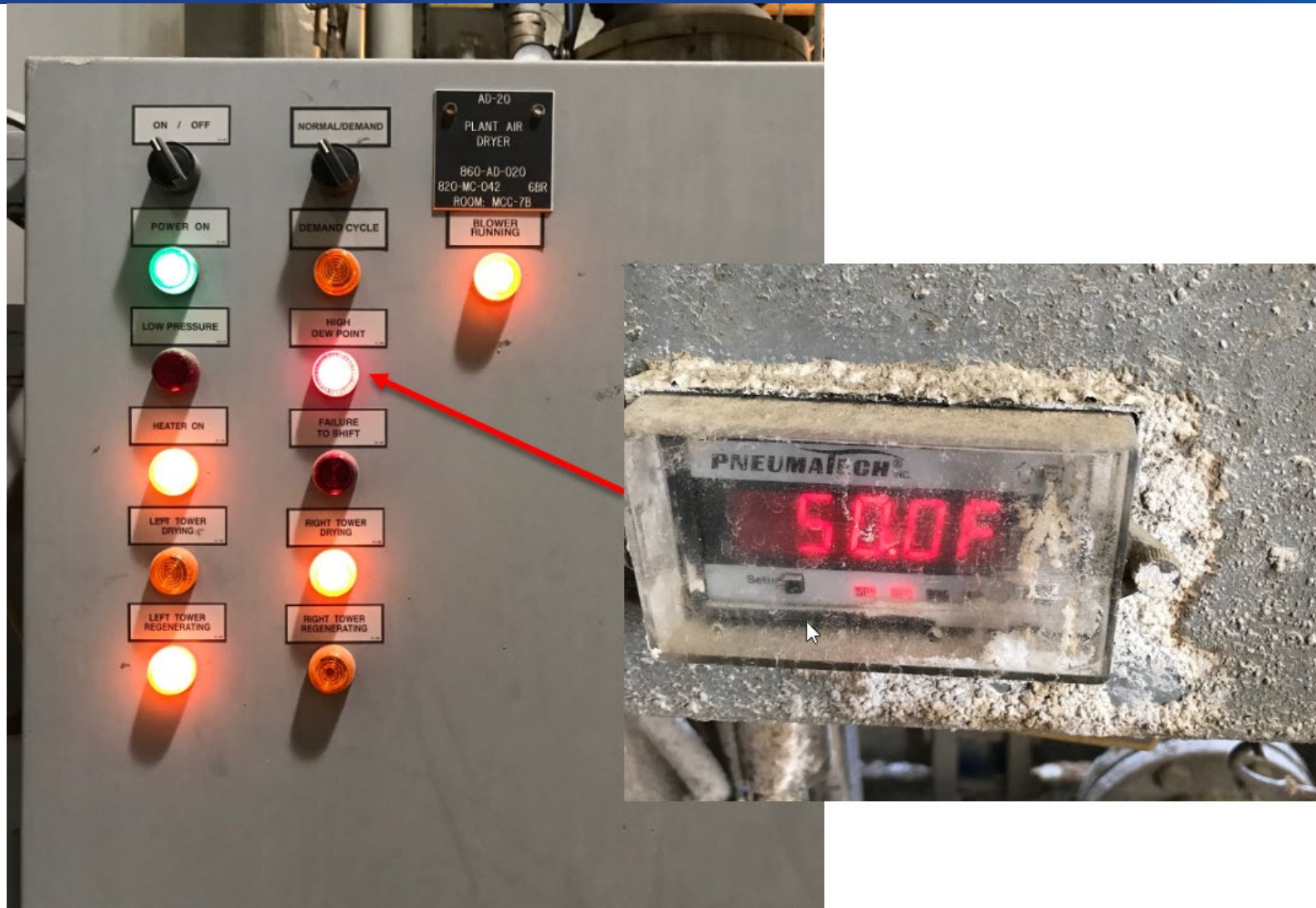

Watch for Problems

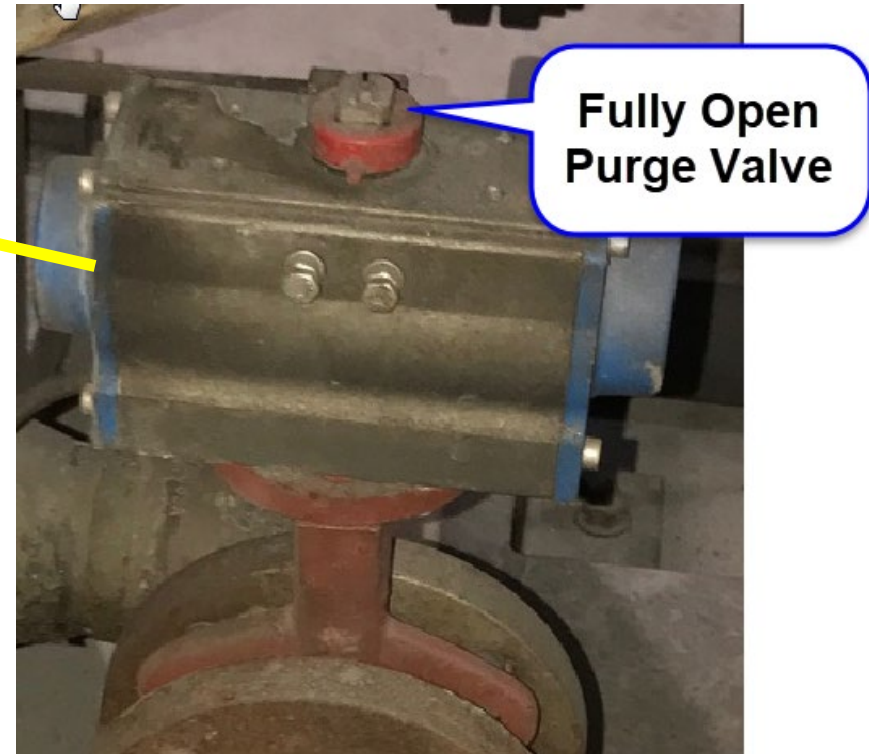
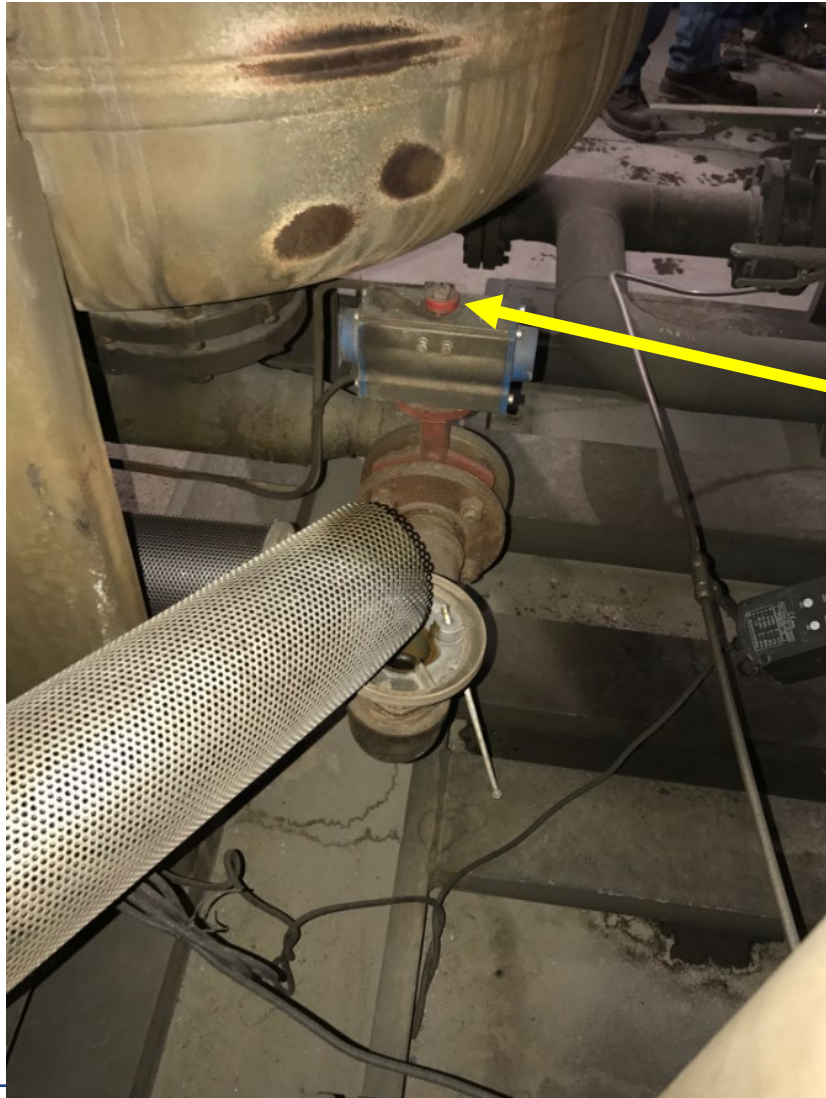

Membrane Dryer

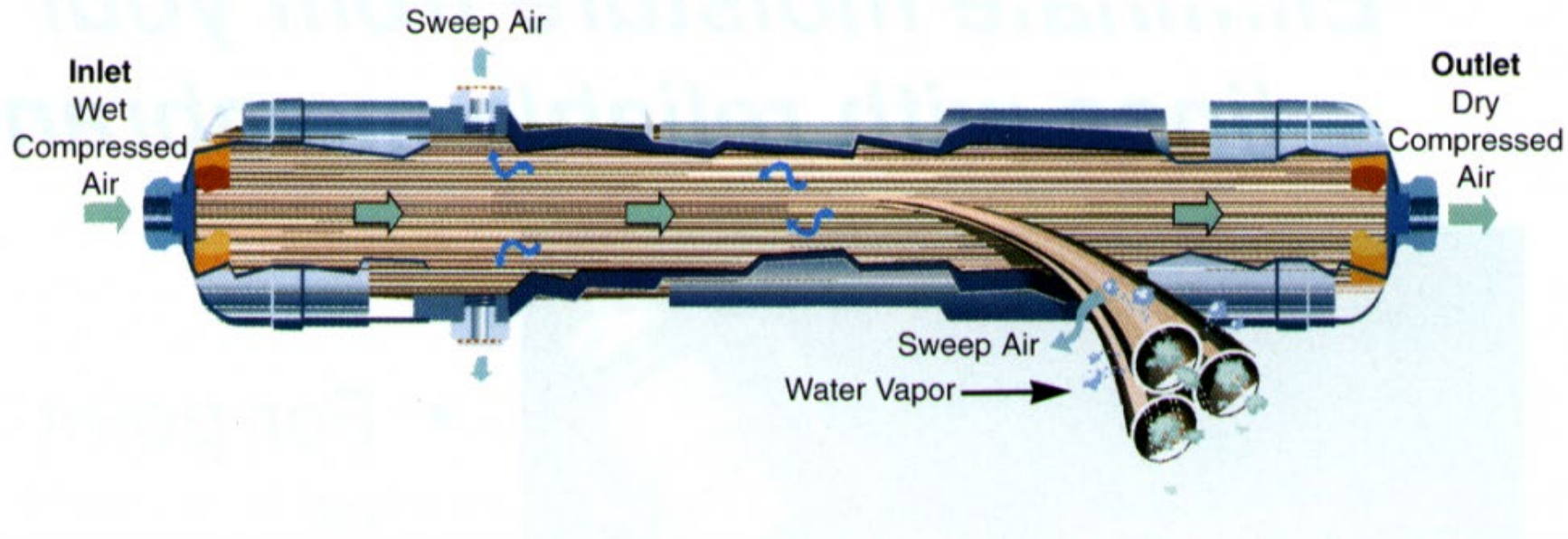

- A membrane dryer suppresses the dew point.
- The dew point achieved normally is 40°F but lower dew points to -40°F can be achieved at the expense of additional purge air loss.
- The power requirement, including the effect of pressure drop through the membrane dryer is **3 – 4 kW/100cfm**

Deliquescent Dryer

- A deliquescent dryer is basically a tank full of salt tablets.
- As the compressed air passes through the salt, the salt attracts water and dissolves into a brine that can be drained off.
- Provide a pressure dew point suppression of around 20°F below the inlet temperature.
- These are the least expensive dryers to purchase and maintain because they have no moving parts and require no power to run.
- The power requirement, including the effect of pressure drop through the dryer is **.8 kW/100cfm**

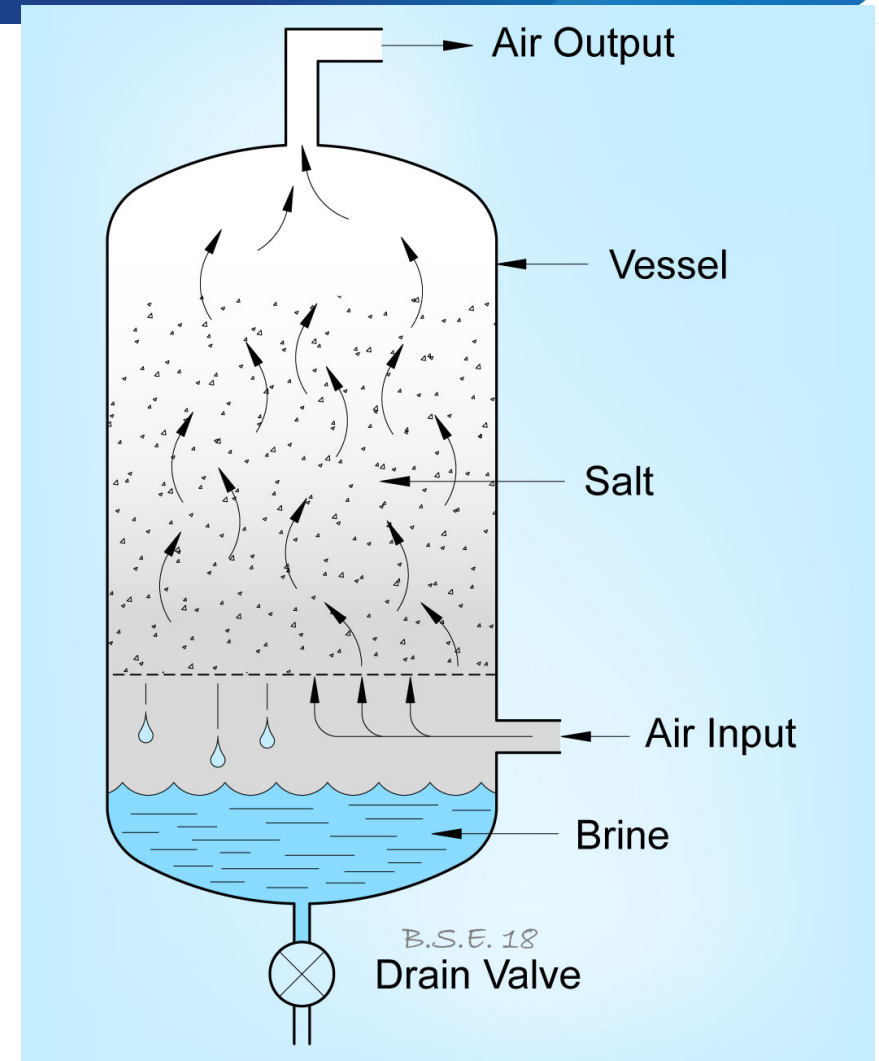

CAGI Refrigerated Compressed Air Dryer Performance Verification Program

- The Compressed Air and Gas Institute (CAGI) sponsors the Performance Verification Program for Refrigerated Compressed Air Dryers.
- The program provides a uniform and commercially practical means of verifying participants' claimed ratings



CAGI Refrigerated Compressed Air Dryer Performance Verification Program

- The following manufacturers of refrigerated compressed air dryers are currently participating in the CAGI Performance Verification Program
 - Atlas Copco
 - Hankison
 - Parker
 - Ingersoll Rand
 - Mikropor
 - Zeks

Date	Model Number	Rated Flow	Rated Outlet Pressure Dew Point	Result
1-15	RD-400	400	39.5	Passed
7-15	RD-500	500	39.5	Passed
3-16	RN325	325	39.5	Passed
3-16	RN250	250	39.5	Passed

CAGI Refrigerated Compressed Air Dryer Performance Verification Program

- Participation in the Program is voluntary and is open to all manufacturers of standalone refrigerated compressed air dryers from 200 – 1000 SCFM.
- On a regular and random basis, the Program Administrator, Intertek Testing Services, selects and tests samples of equipment to verify that actual performance meets the manufacturer's certified published performance ratings.

DRYER DATA SHEET
Refrigerant Dryers

MODEL DATA				
1	Manufacturer			
2	Date	13 03 2017		
3	Model Number			
4	Cycling / Non-Cycling	NON-CYCLING		
5	Refrigerant Type	R134a		
6	Air/Water Cooled	Air Cooled		
7	Voltage	230 V		
	DESCRIPTION	FULL FLOW	10% FLOW	UNITS
6	Tested Flow ^a	200	20	scfm ^b
7	Outlet Pressure Dewpoint	42,9	39,0	°F
8	Pressure Drop	2,2	1	psi(d)
9	Total Dryer Input Power	2,42	2,15	kW
10	Specific Package Power ^c	1,21	10,77	kW/100 scfm

DRYER DATA SHEET
Refrigerant Dryers

MODEL DATA				
1	Manufacturer			
2	Date	12/29/16		
3	Model Number			
4	Cycling/Non-Cycling	Cycling		
5	Refrigerant Type	R-404A		
	DESCRIPTION	FULL FLOW	10% FLOW	UNITS
6	Tested Flow	200	20	scfm ^b
7	Outlet Pressure Dewpoint	40.5	40.5	°F
8	Pressure Drop	2.8	0.7	psi(d)
9	Total Dryer Input Power	2.1	.63	kW
10	Specific Package Power ^c	1.05	3.15	kW/100 scfm

Notes:

10. Total Dryer Input Power/tested flow x 100

WHY DO YOU NEED A FILTER?

Which Contaminants do we find in compressed air?

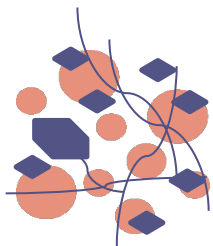

SOLID - PARTICLES



WATER



OIL



GASEOUS CONTAMINANTS

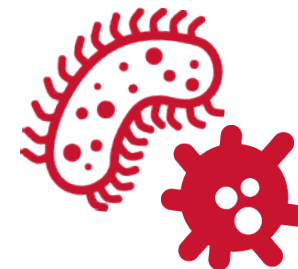

MICROBIOLOGICAL CONTAMINANTS

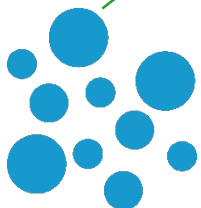

LIQUID



VAPOR (HUMIDITY)



LIQUID (AEROSOL)



VAPOR (HYDROCARBON)

THE RELATIVE SIZE OF PARTICLES

From the COVID-19 pandemic to the U.S. West Coast wildfires, some of the biggest threats now are also the most microscopic.

A particle needs to be 10 microns (μm) or less before it can be inhaled into your respiratory tract. But just how small are these specks?

Here's a look at the relative sizes of some familiar particles \blacktriangleright

HUMAN HAIR 50-180 μm \blacktriangleright
FOR SCALE

FINE BEACH SAND 90 μm \blacktriangleright

GRAIN OF SALT 60 μm \blacktriangleright

WHITE BLOOD CELL 25 μm \blacktriangleright

GRAIN OF POLLEN 15 μm \blacktriangleright

DUST PARTICLE (PM₁₀) <10 μm \blacktriangleright

RED BLOOD CELL 7-8 μm \blacktriangleright

RESPIRATORY DROPLETS 5-10 μm \blacktriangleright

DUST PARTICLE (PM_{2.5}) 2.5 μm \blacktriangleright

BACTERIUM 1-3 μm \blacktriangleright

WILDFIRE SMOKE 0.4-0.7 μm \blacktriangleright

CORONAVIRUS 0.1-0.5 μm \blacktriangleright

T4 BACTERIOPHAGE 0.225 μm \blacktriangleright

ZIKA VIRUS 0.045 μm \blacktriangleright



Pollen can trigger allergic reactions and hay fever—which 1 in 5 Americans experience every year.

Source: Harvard Health

The visibility limits for what the naked eye can see hovers around 10-40 μm .



Respiratory droplets have the potential to carry smaller particles within them, such as dust or coronavirus.



Wildfire smoke can persist in the air for several days, and even months.

ISO 8573-1 Compressed Air Quality Classes Simple Chart

ISO 8573-1:2010 Compressed Air Quality Classes

Class	Max. Particle Size		Pressure dewpoint		Max Oil Content (mg/m ³)
	(µm)	(mg/m ³)	(°C/°F)	(g/m ³)	
0	Specified by the equipment manufacturer/supplier and greater than class 1				
1	0.1	0.1	-70/-94	0.003	0.01
2	1	1	-40/-40	0.12	0.1
3	5	5	-20/-4	0.88	1
4	15	8	3/37	6	5
5	40	10	7/45	7.8	25
6	--	--	10/50	9.4	--
7	--	--	Not Specified		--

Note: the Class 0 certification was created in response to industry needs for oil-free air. Stating Class 0 without an agreed specification will mean it is not in accordance with the standard. Class 0 air purity is best achieved at the point of use to minimize cost.

ISO 8573-2010 - Contaminants and purity classes

International standard for compressed air purity classification

ISO 8573-1:2010	Dirt			Mass concentration mg/m ³	Water		Oil
	Maximum number of particles per m ³				Vapor pressure dewpoint	Liquid g/m ³	Total oil (aerosol liquid and vapor) mg/m ³
	0.1 - 0.5 micron	0.5 - 1 micron	1 - 5 micron				
0	As specified by the equipment user or supplier and more stringent than Class 1						
1	≤ 20000	≤ 400	≤ 10	-	≤ -70°C/-94°F	-	0.01
2	≤ 400000	≤ 6000	≤ 100	-	≤ -40°C/-40°F	-	0.1
3	-	≤ 90000	≤ 1000	-	≤ -20°C/-4°F	-	1
4	-	-	≤ 10000	-	≤ +3°C/+37.4°F	-	5
5	-	-	≤ 100000	-	≤ +7°C/+44.6°F	-	-
6	-	-	-	≤ 5	≤ +10°C/+50°F	-	-
7	-	-	-	5 - 10	-	≤ 0.5	-
8	-	-	-	-	-	0.5 - 5	-
9	-	-	-	-	-	5 - 10	-
X	-	-	-	> 10	-	> 10	> 10

ISO 22000



- The Safe Quality Food Institute (SQFI) has introduced a new Safe Quality Food Manual (ISO 22000) in the U.S. in 2018
- It includes a significant change regarding compressed air and other compressed gases such as nitrogen and carbon dioxide.
- Previously, there had been no statement regarding how or when to monitor compressed air quality.
- Going forward, food processors must test (at least) annually for factors including particulate, water, oil, microbiological and relevant gaseous testing in compressed air or other gases.
- A verification of the effectiveness of compressor maintenance and filtration that a management facility has in place should also be conducted.

Compressed Air Testing Kits



Kit Purchase

\$600

Kit Rental

\$60

Manufacturing Air ▾

Dietary Supplements

Food Grade Air

Food Packaging

Instrument / Nuclear

Medical Device

Pet Food

Pharmaceutical

Pure Gas Testing

Microbial Contaminants >

Validations and Qualifications

Environmental ▾

Ambient Air Testing

Contact Plate Testing

Surface Swab Testing

Microbial Contaminants >

- K810 – the AirCheck✓ Kit™ for Particles, Water, and Oil
- K811 – the AirCheck✓ Kit™ for Gases, Particles, Water, and Oil
- KX00 – the AirCheck✓ Kit™ for Microorganisms

Compressed Air Filters

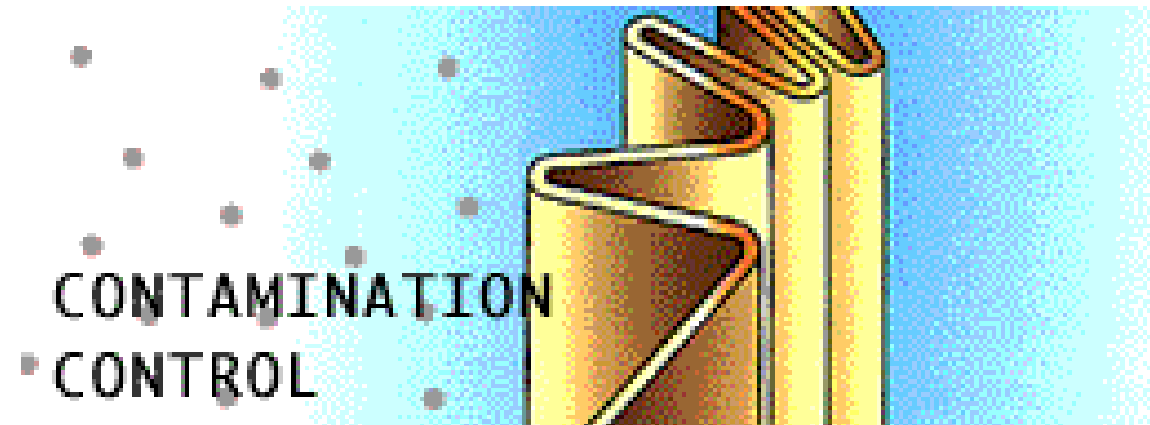
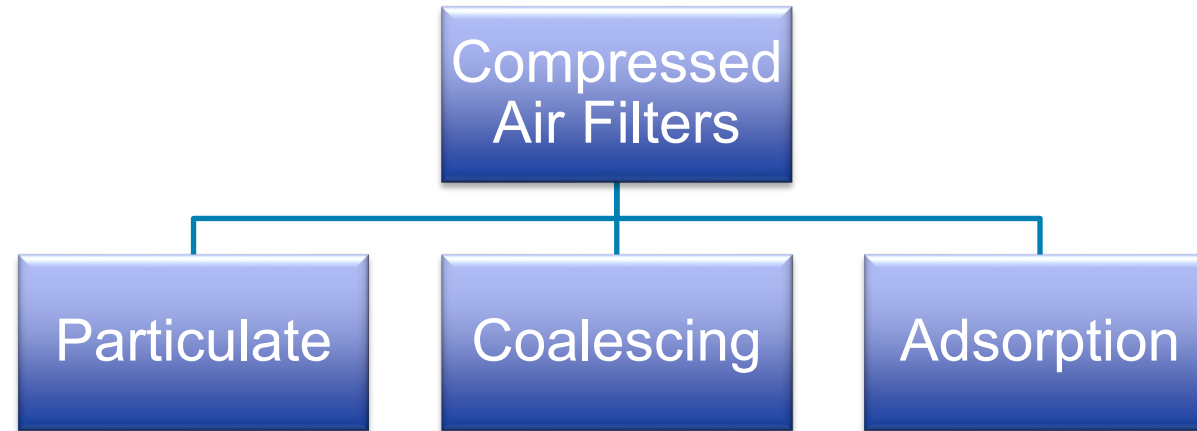

FACTS

- 1 cubic foot of typical atmospheric air contains approximately 4,000,000 particles.
- 80% are 2 micron in size or less.
- 40 micron is the smallest the human eye can see.

ATMOSPHERIC CONTAMINATION

- Dirt
- Water
- Hydrocarbon vapor from unburnt fuels and industrial processes

AFTER THE COMPRESSOR....

- Dirt
- Oil
- Water
- Carbon
- Wear particles

IN THE PIPEWORK.....

- Dirt
- Water / oil emulsion
- Microbes
- Pipe scale
- Rust

COALESCING FILTERS

- Removes
 - Dirt particles down to 0.01 micron
 - Oil aerosol content down to 0.01 ppm

THIS PREVENTS.....

- Rust and corrosion
- Sticking valves and cylinders
- Damage to air operated equipment
- Damage to finished products
- Increased costs due to lost production

BENEFITS.....

- Longer tool life
- Less maintenance
- Clean pipework
- Reduced running costs / down time
- Consistent quality of finished product

Filters



Filters

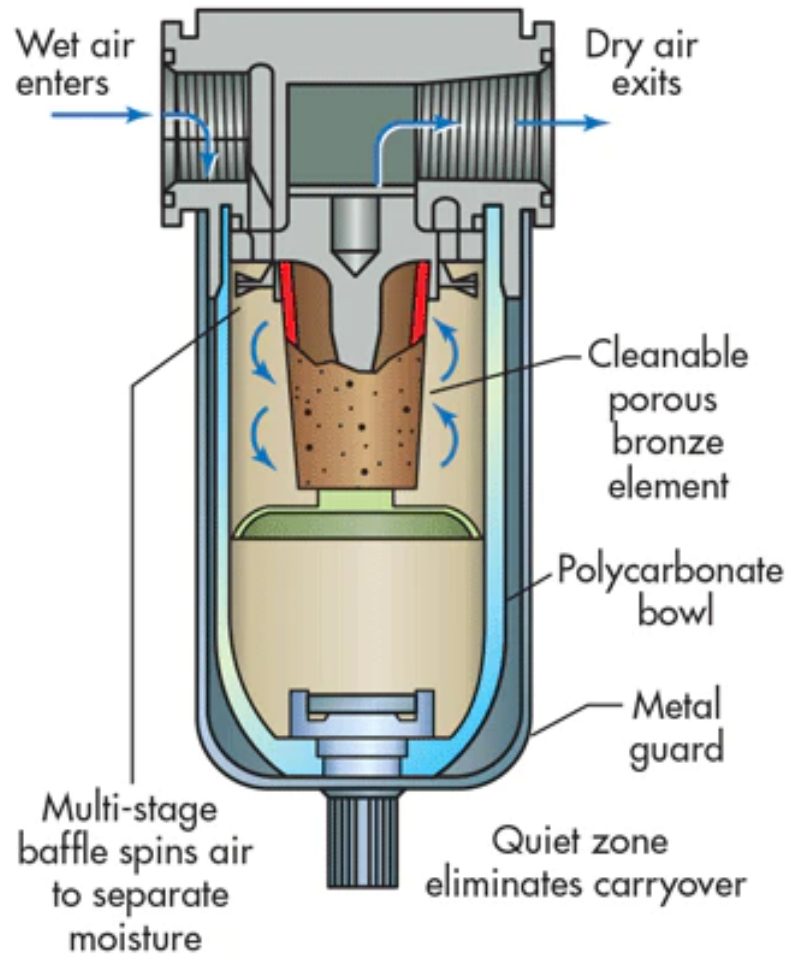

- Here is a cutaway view of airflow through a compressed-air point-of-use filter.
- Filters are rated according to the minimum particle size that their elements will trap.
- Although filters rated at 40 to 60 μm are adequate for protecting most industrial applications, many point-of-use filters are rated at 5 μm .
- Finer ratings increase the pressure drop through the filter, which equates to higher energy cost to compress the air.
- In addition, finer filters clog more rapidly, also increasing pressure drop.
- Therefore, using a filter finer than necessary does no harm to downstream components, but increases air system operating cost.

Filters

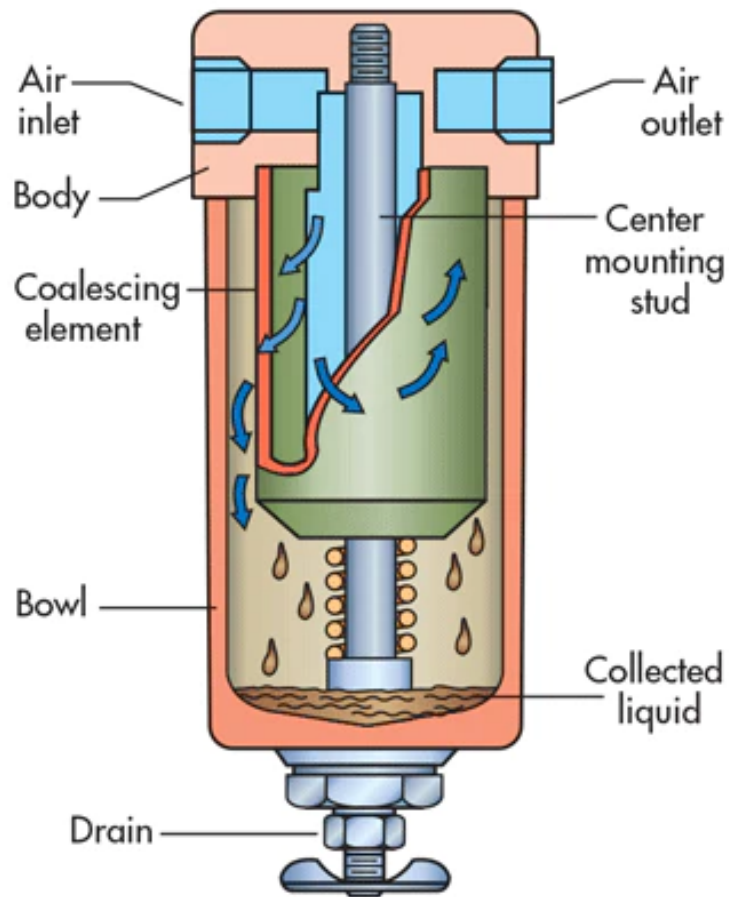

- Here is a cutaway view of airflow through typical coalescing compressed air filter.
- Coalescing filters are often rated to remove aerosols that are substantially smaller than the nominal size of the smallest solid particle that would be captured.
- Some models offer dual-stage filtration; the first removes solid particulates to protect the coalescing element in the second stage.
- Because all coalescing filters create a greater restriction to the airflow, pressure losses will be higher than those of conventional compressed air filters.
- Choose a coalescing filter based on acceptable oil carryover, expected airflow rate, and pipe-connection size.
 - A coalescing filter rated at 0.1 ppm will typically have a clean, wetted pressure drop between 2 and 5 psig, while a high-efficiency filter rated at 0.01 ppm can cause as much as a 10 psig drop once it becomes wetted or fully saturated during service.

COALESCING ELEMENT

- High efficiency borosilicate microfiber filter media
- Anti re-entrainment barrier improves drainage
- Compatible with mineral and synthetic lubricants

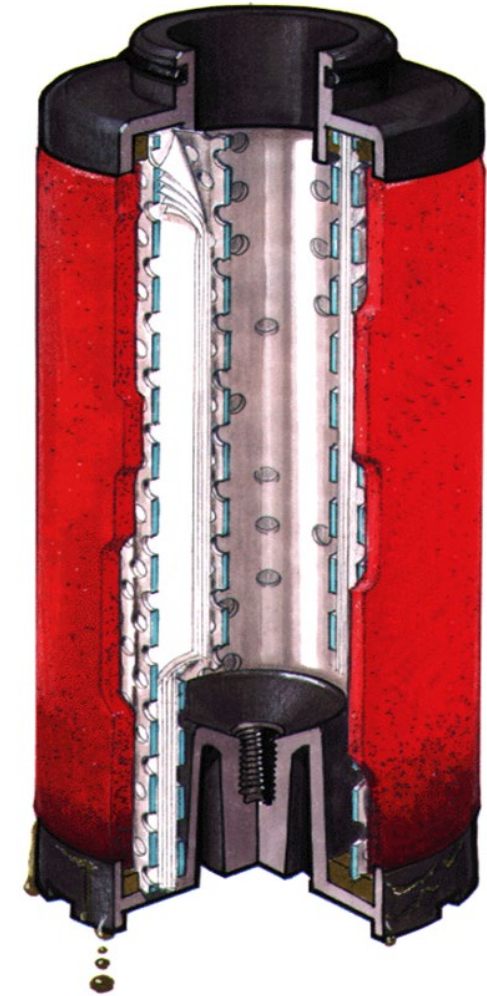

Coalescing Process

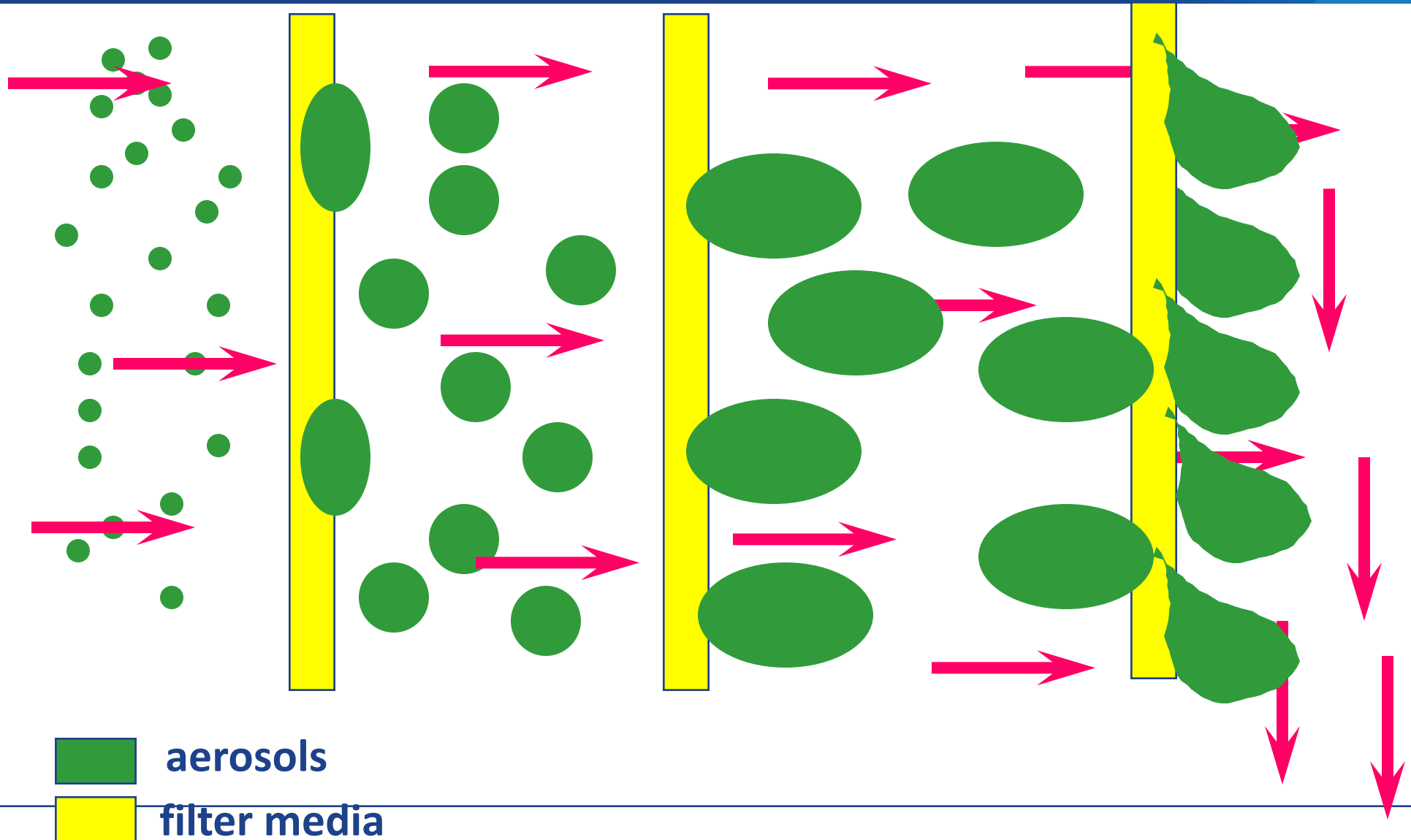

Reduce System Pressure Drop Losses

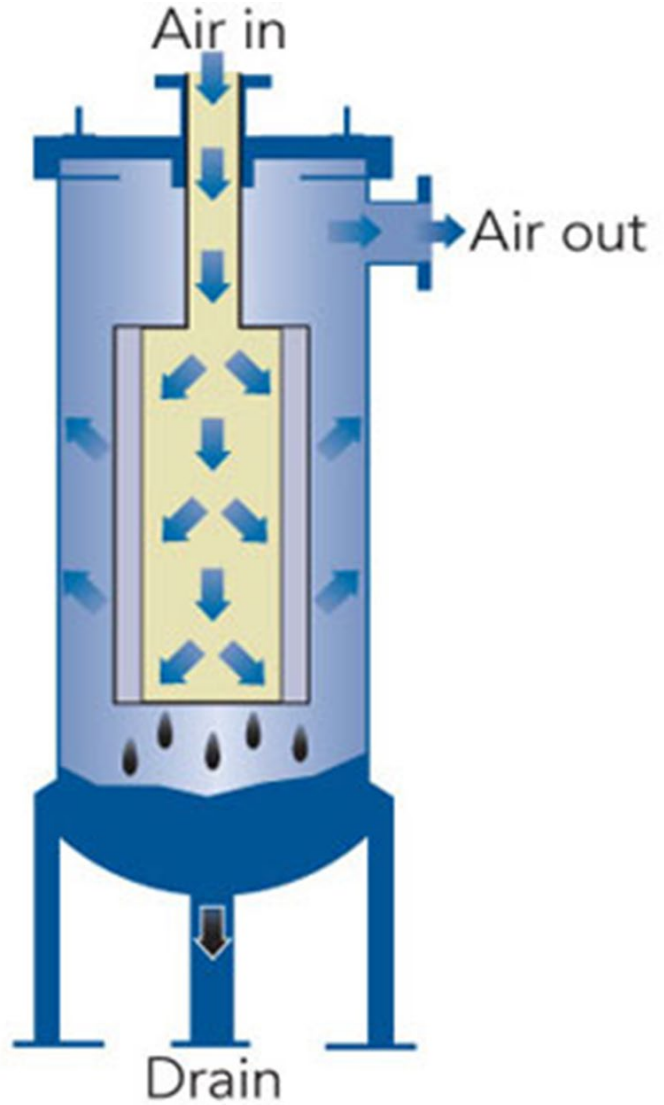

MECHANISMS OF FILTRATION

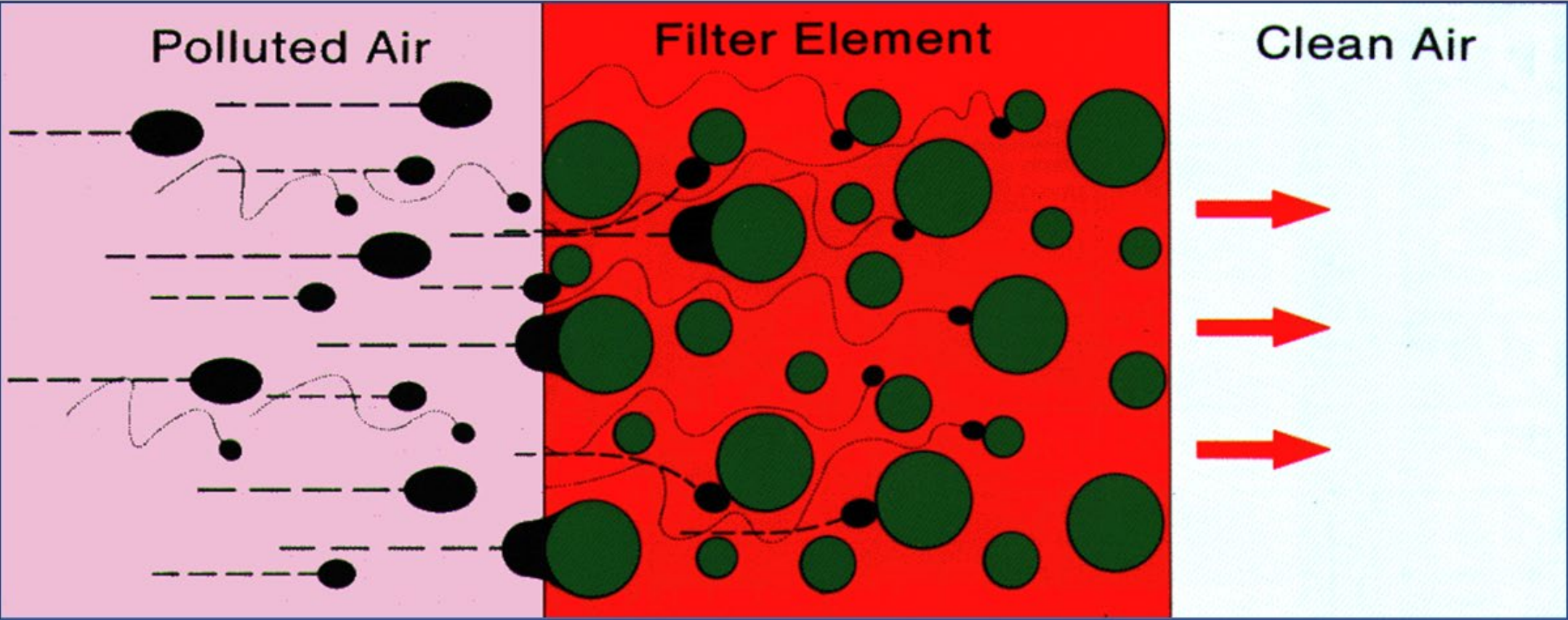

MECHANISMS OF FILTRATION for Mist Eliminator Filter

- Assuming that gravity separation can be disregarded as an effective option, the remaining 3 mechanisms provide the design basis for mist elimination equipment:
 - Direct Interception** - affecting particles over 1 micron in size.
 - Inertial Impaction** - affecting particles in the 0.3 to 1 micron size range.
 - Diffusion** (Brownian Movement) affects particles below 0.3

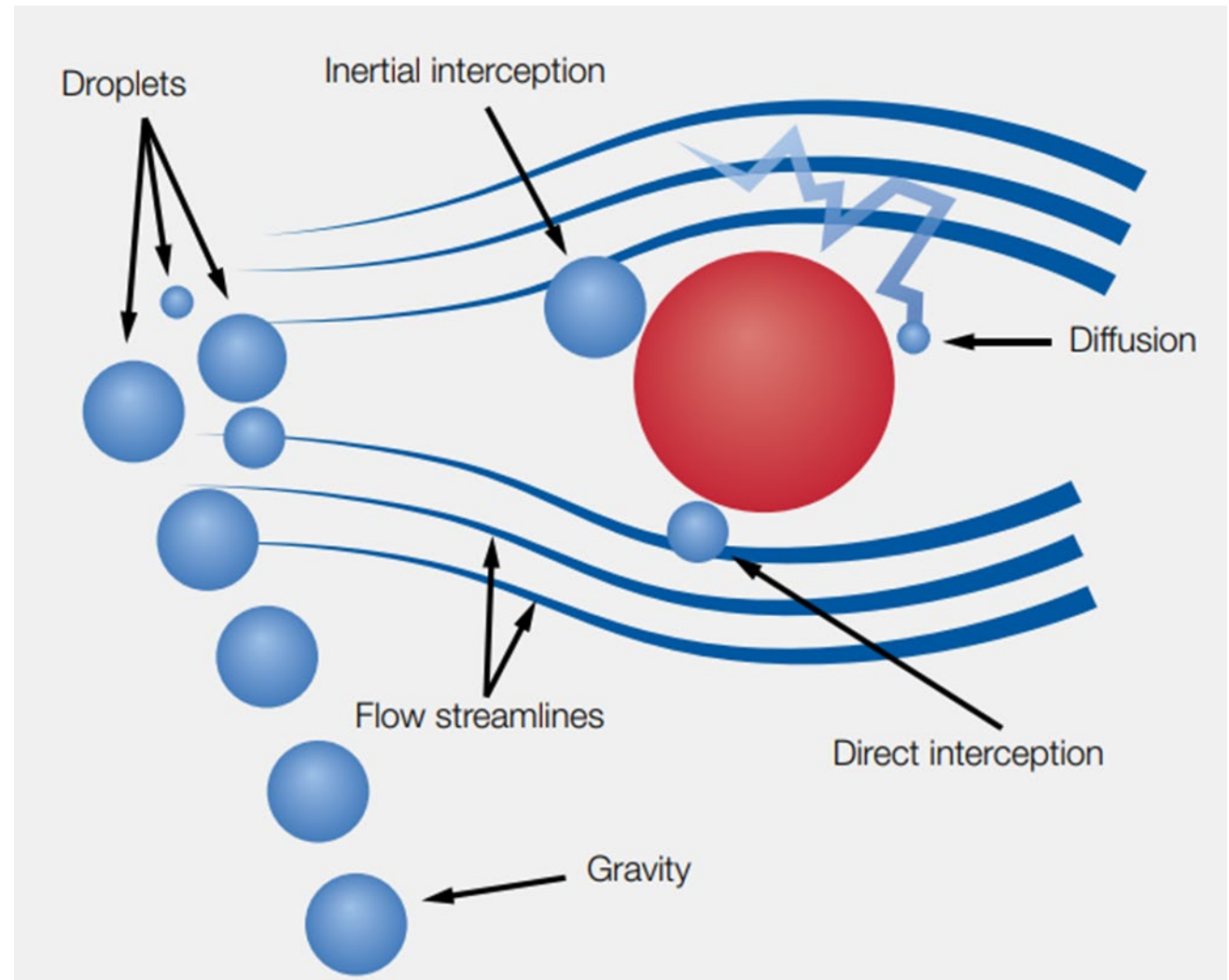

ACTIVATED CARBON ADSORPTION FILTERS

- Removes Oil Vapors and Odors
 - Prevents product Contamination
 - Increased costs due to lost production
 - Offers OSHA compliance for breathing air and pharmaceutical requirements
- This is not a coalescing filter!
 - Removes gaseous hydrocarbons and odors
 - Maximum remaining oil content to 0.003 ppm

Where Are the Filters Installed?

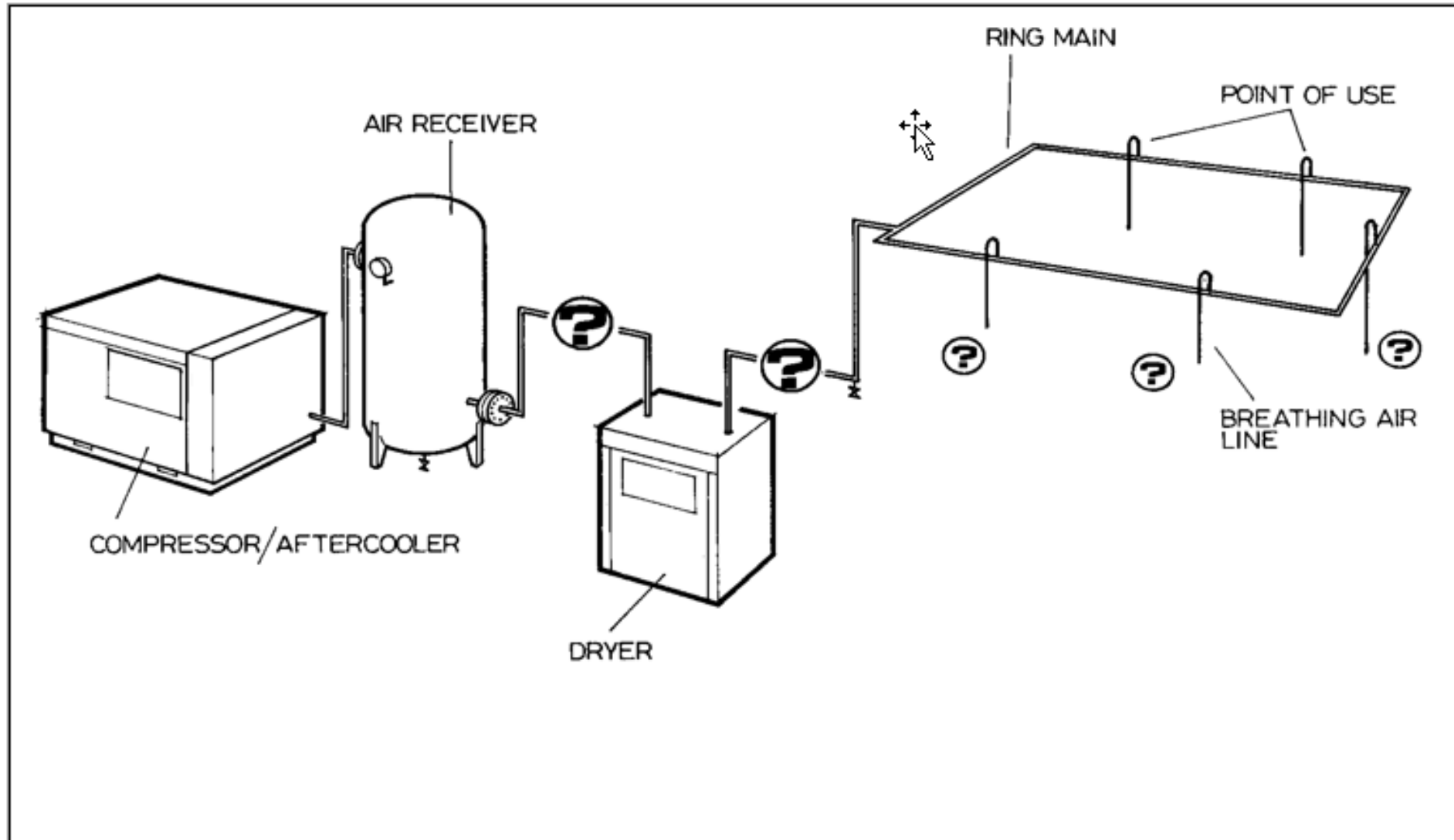

WHY DO YOU NEED Condensate Drains?

Capacity	100	cfm
	102	psi (g)
	80	°F
Air Usage	100	cfm

Water Remaining in Compressed Air

Imperial Units

Drying Method	Dewpoint	Gallons Week	Gallons Annum
No Treatment	127°F	76.4	3975.0
After Cooler	98°F	32.6	1693.0
Deliquescent	87°F	23.7	1232.8
Refrigerant	37°F	4.3	225.9
Desiccant	-40°F	0.09	4.8

Metric Units

Drying Method	Dewpoint	Litres Week	Litres Annum
No Treatment	53°C	347.5	18068.2
After Cooler	37°C	148.0	7695.4
Deliquescent	26°C	107.8	5603.7
Refrigerant	3°C	19.7	1026.6
Desiccant	-40°C	0.4	22.0

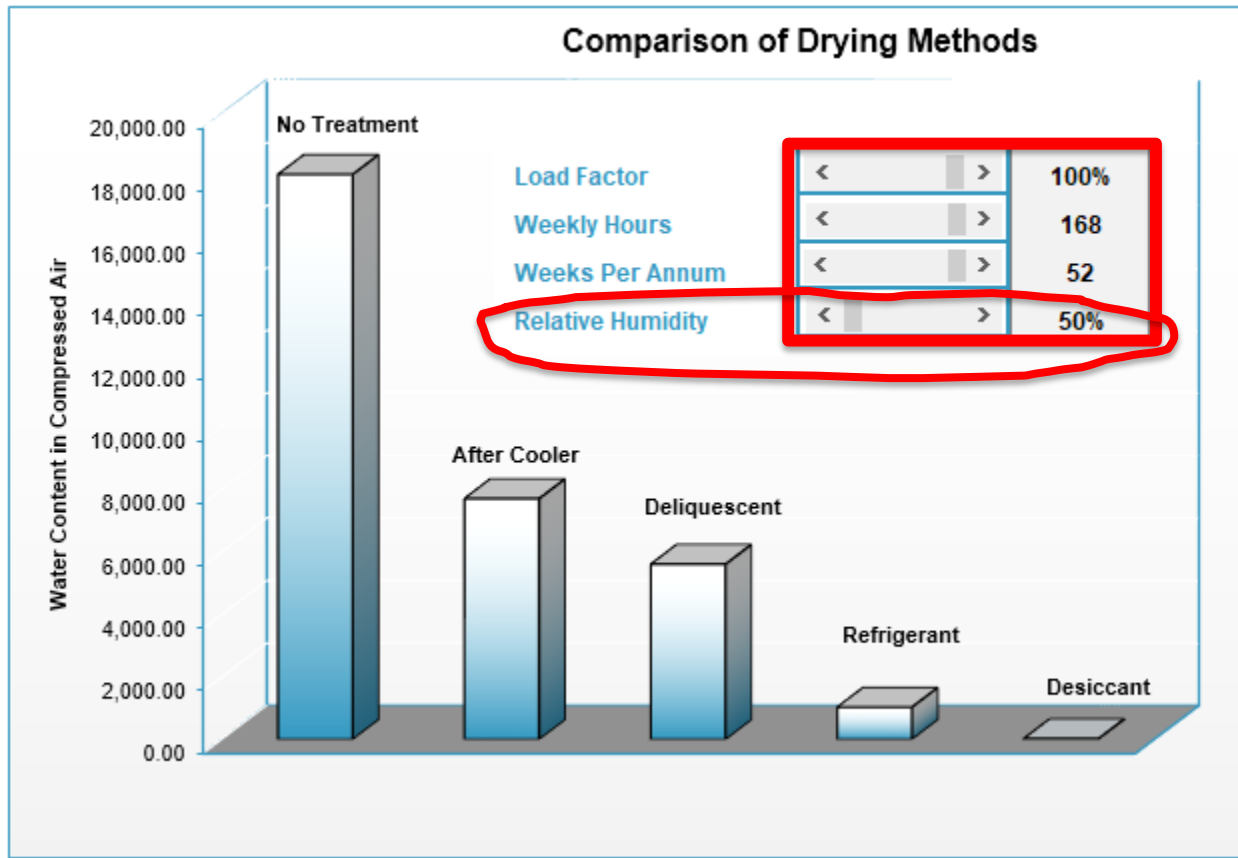

Capacity	100	cfm
	102	psi (g)
	80	°F
Air Usage	100	cfm

Water Remaining in Compressed Air

Imperial Units

Drying Method	Dewpoint	Gallons Week	Gallons Annum
No Treatment	154°F	145.2	7552.5
After Cooler	98°F	32.6	1693.0
Deliquescent	87°F	23.7	1232.8
Refrigerant	37°F	4.3	225.9
Desiccant	-40°F	0.09	4.8

Metric Units

Drying Method	Dewpoint	Litres Week	Litres Annum
No Treatment	68°C	660.2	34329.5
After Cooler	37°C	148.0	7695.4
Deliquescent	26°C	107.8	5603.7
Refrigerant	3°C	19.7	1026.6
Desiccant	-40°C	0.4	22.0

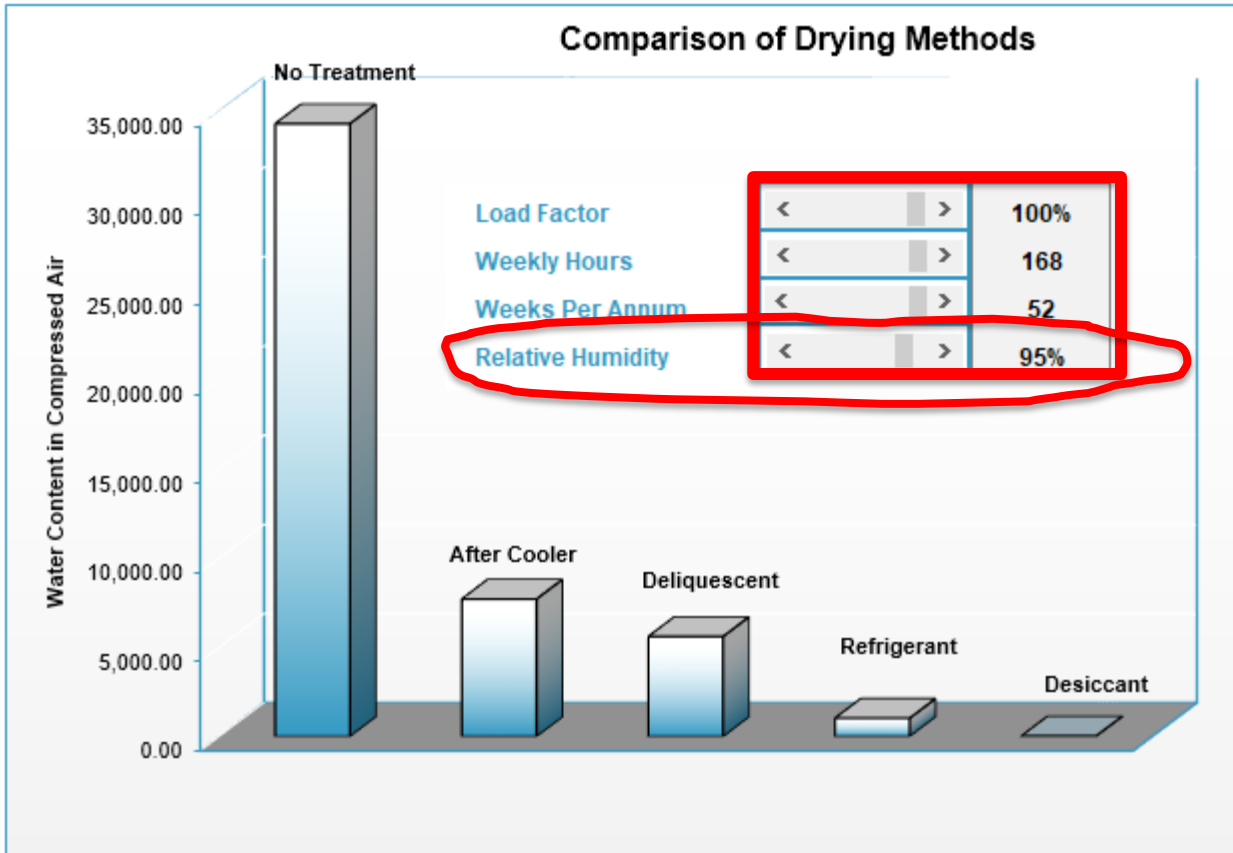

MOISTURE CONTENT

- 7000 grains of water equals one pound or one pint
- 93,600 divided by 7000 equals 13.4 pounds or 13 pints

Just a 10° F drop in temperature will allow 13 pints (1.625 gallons) of water to condense into the piping system in 40 hours!

Even with this amount of water removed, the RH is still 100% and the dew point down stream of the aftercooler is now 70° F

Condensate removal without the loss of compressed air.

- Inspect drain traps regularly and repair as necessary.
- Do not allow open manual drain valves.
- Use drain traps which sense the presence of condensate and drain it without loss of compressed air.

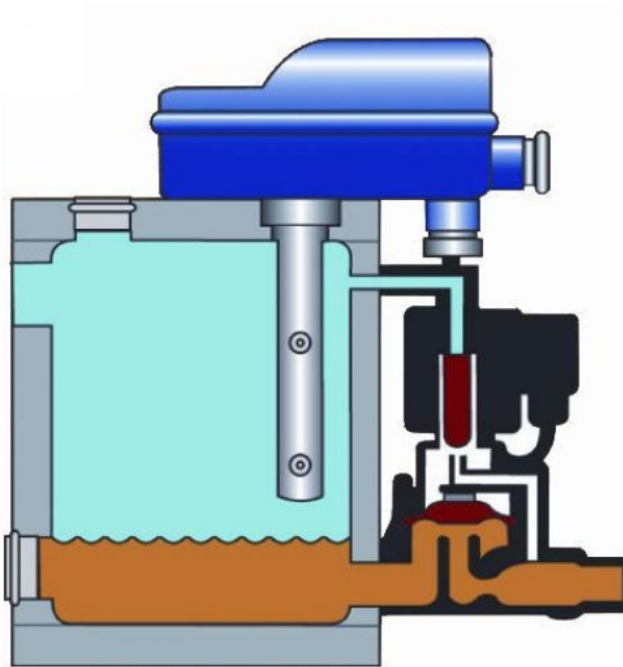

VS



VS



Install Drain-All(s) as shown below.

Install tee for balance line connection.

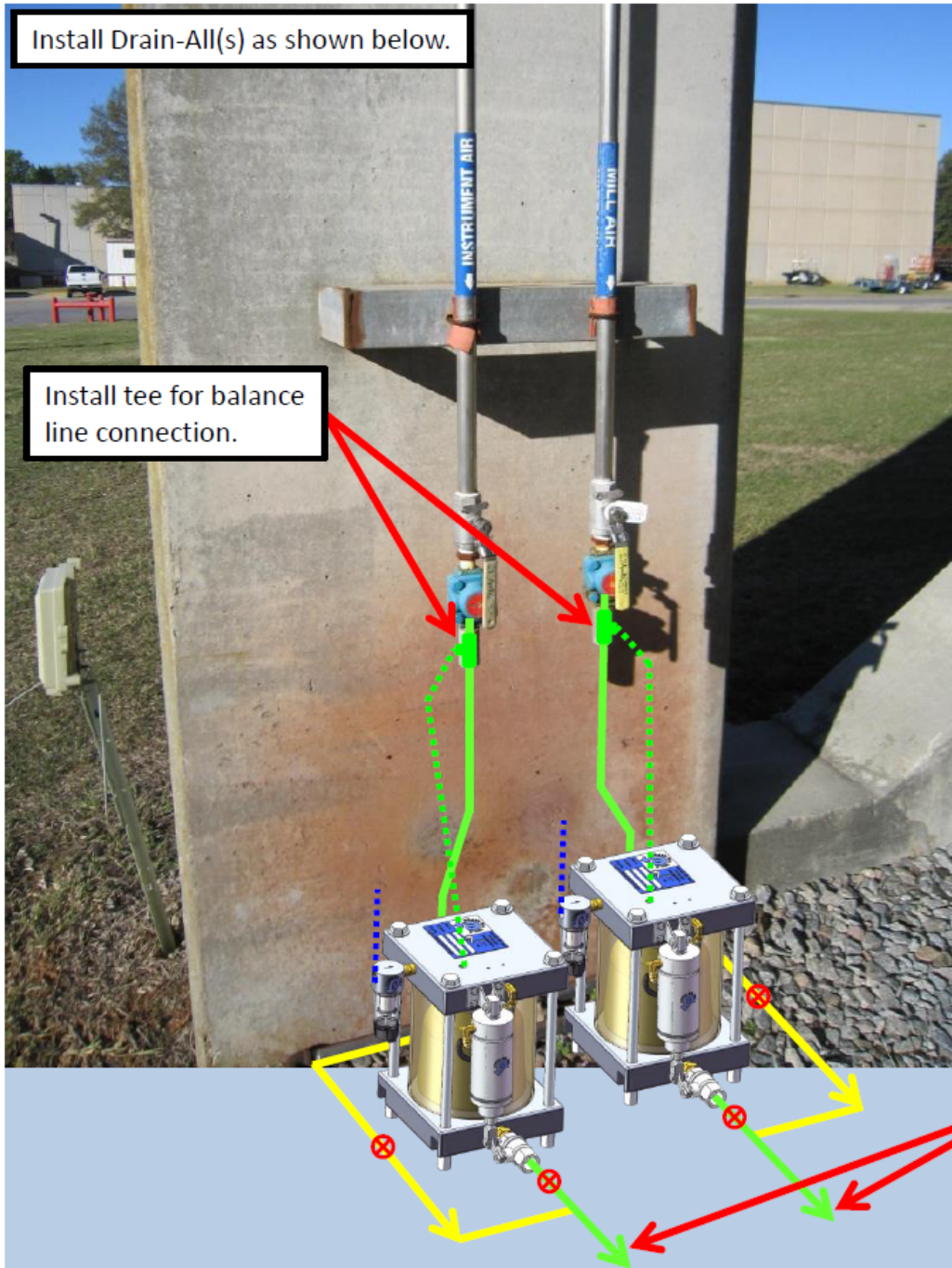

The orientation and location of the Drain-All trap should be adjusted to best accommodate piping and discharge direction to drain considering available space.



Balance Lines should be connected back to the vessel at a location with the same pressure as the condensate drain. Balance line should have no low spots that can hold condensed liquid that would stop proper air flow. Reference section 1, BL2.



Control air should come from a clean, dry air source as shown in Section 1.

Heaters and heat tracing on the pipes is required due to environmental conditions. Insulate trap to prevent freezing.

Drain point piped to existing drain.

Drip Legs

Condensate Drains

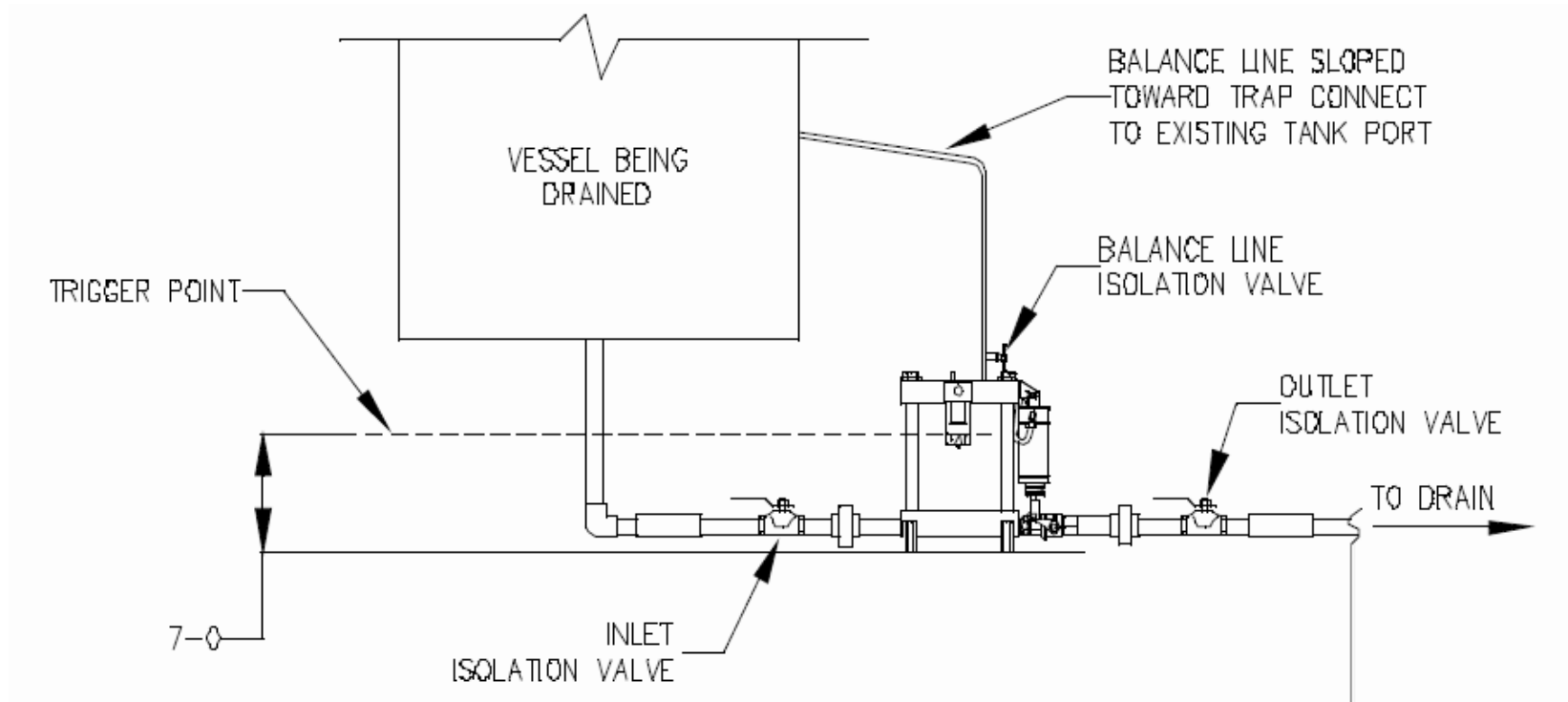

Condensate Drains

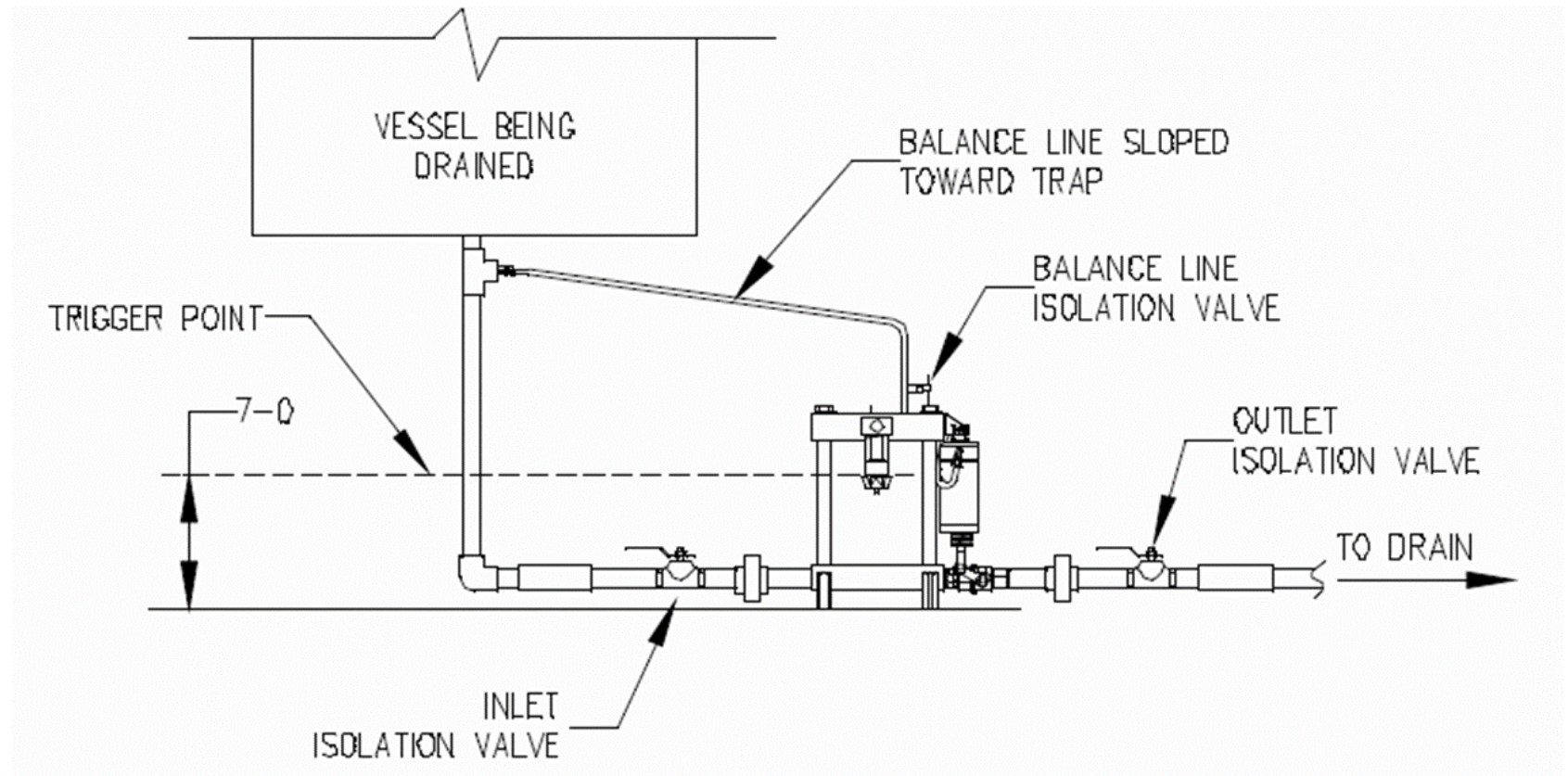

Condensate Drains

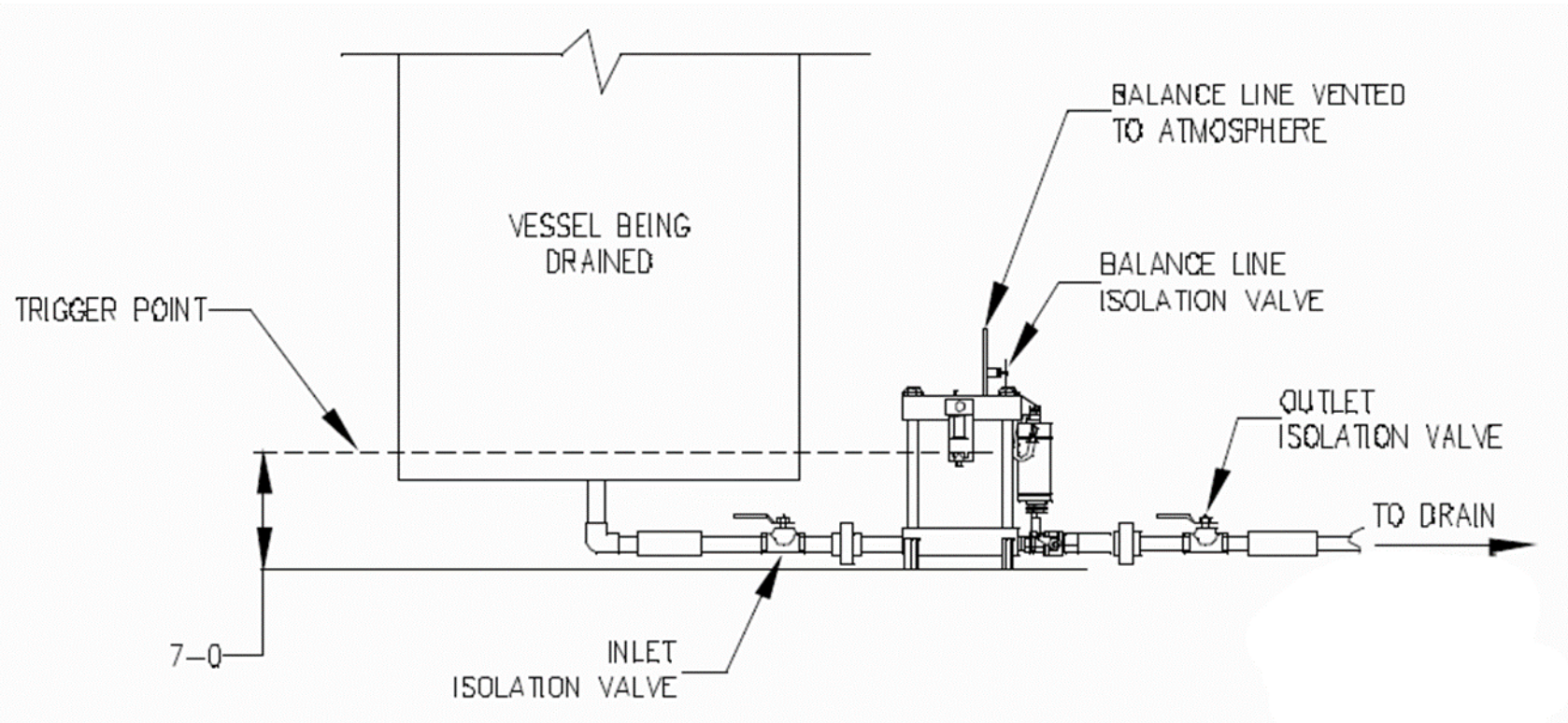

Condensate removal without the loss of compressed air



Is the condensate drain even working?







Condensate removal without the loss of compressed air



Condensate removal without the loss of compressed air





What About Inlet Air Filters?

Inlet Filters

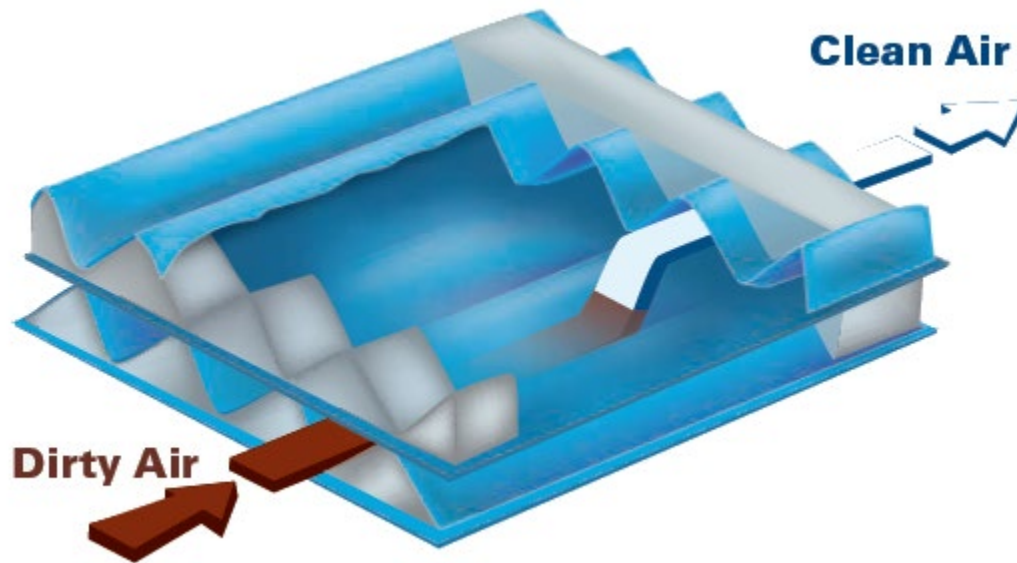

- The inlet air filter prevents dirt and dust particles from entering the compressor.
- This minimizes wear and tear on the airend, extends air/oil separator and lube filter life, and ensures cleaner compressed air to the plant or your mobile power tools and applications.

Inlet Filters

- To prevent adverse effects from intake air quality, it is important to ensure that the location of the entry to the inlet pipe is as free as possible from ambient contaminants, such as rain, dirt, and discharge from a cooling tower.
- If the air is drawn from a remote location, the inlet pipe size should be increased in accordance with the manufacturer's recommendation to prevent pressure drop and reduction of mass flow.
- A pressure gauge indicating pressure drop in inches of water is essential to maintain optimum compressor performance

Inlet Filter Replacement

- As a compressor intake air filter becomes dirty, the pressure drop across it increases, reducing the pressure at the air end inlet and increasing the compression ratios.
- The cost of this loss of air can be much greater than the cost of a replacement inlet filter, even over a short period of time.
- For a 200 horsepower (hp) compressor operating, 7 days a week (8,760 hours per year) with a \$0.05/kilowatt hour (kWh) electricity rate, a dirty intake filter can decrease compressor efficiency by 1%–3%,
 - Which can translate into higher compressed air energy costs of between \$654 and \$1,960 per year.

Inlet Filters

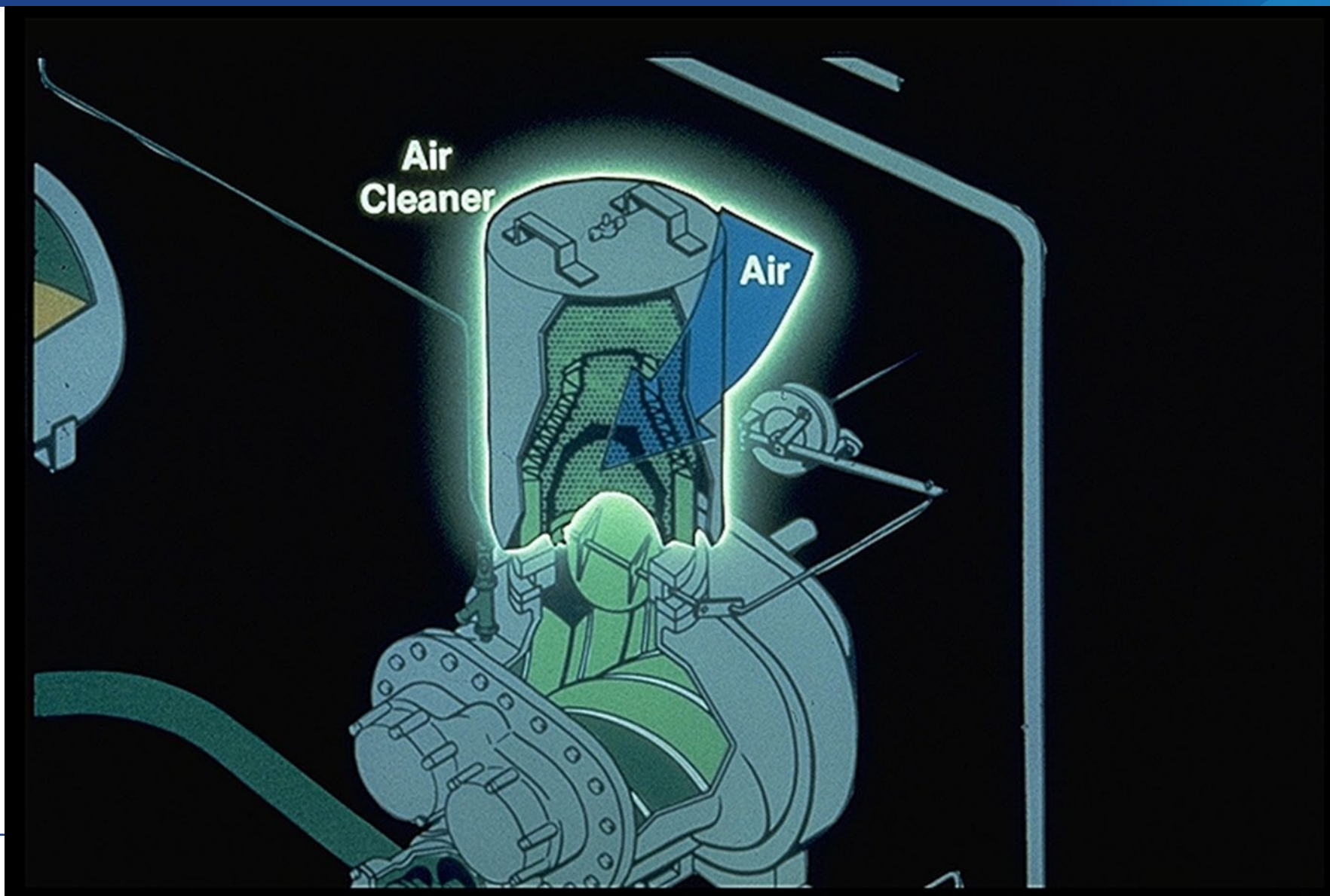

Inlet Filters

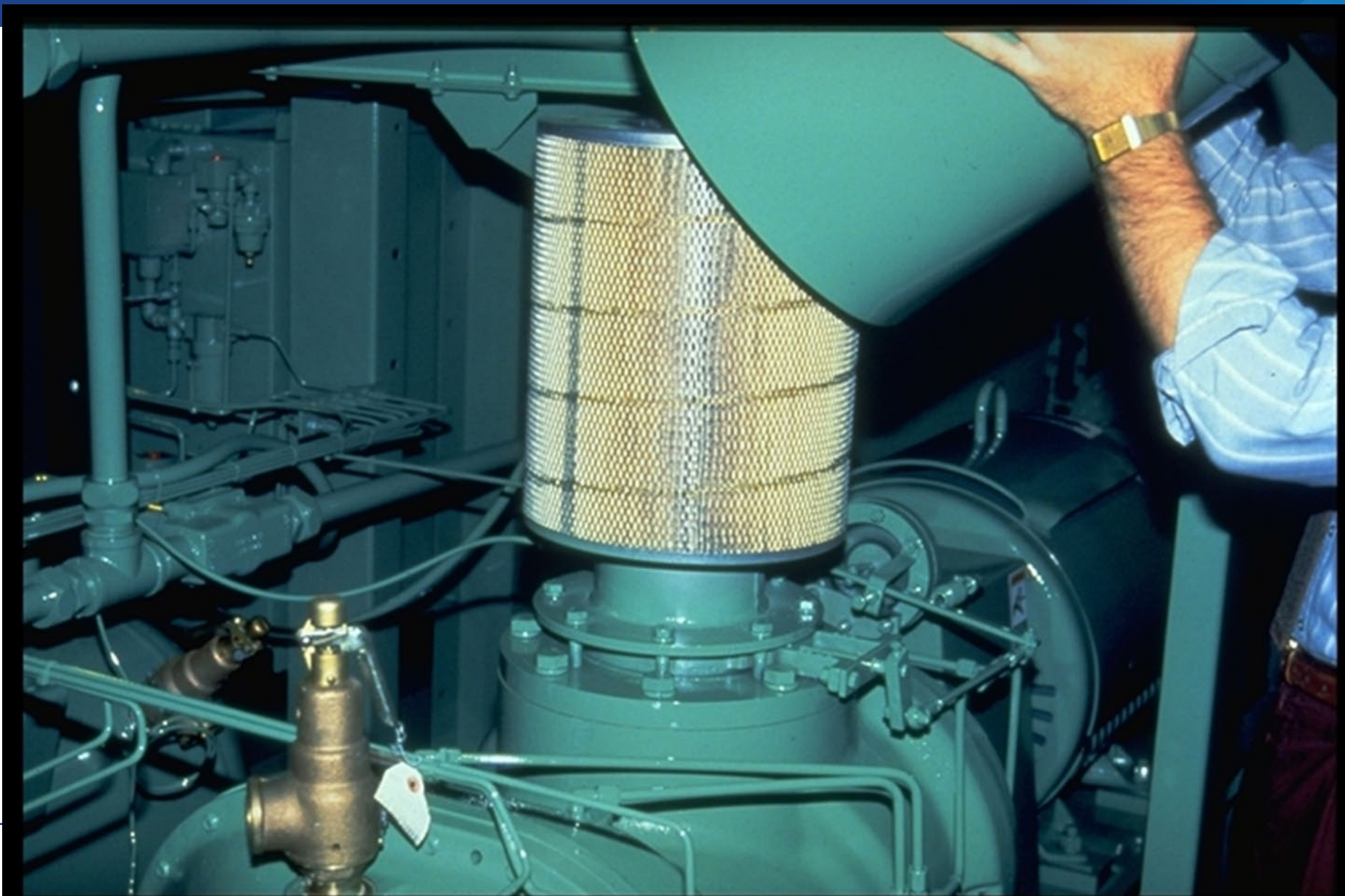

Inlet Filters

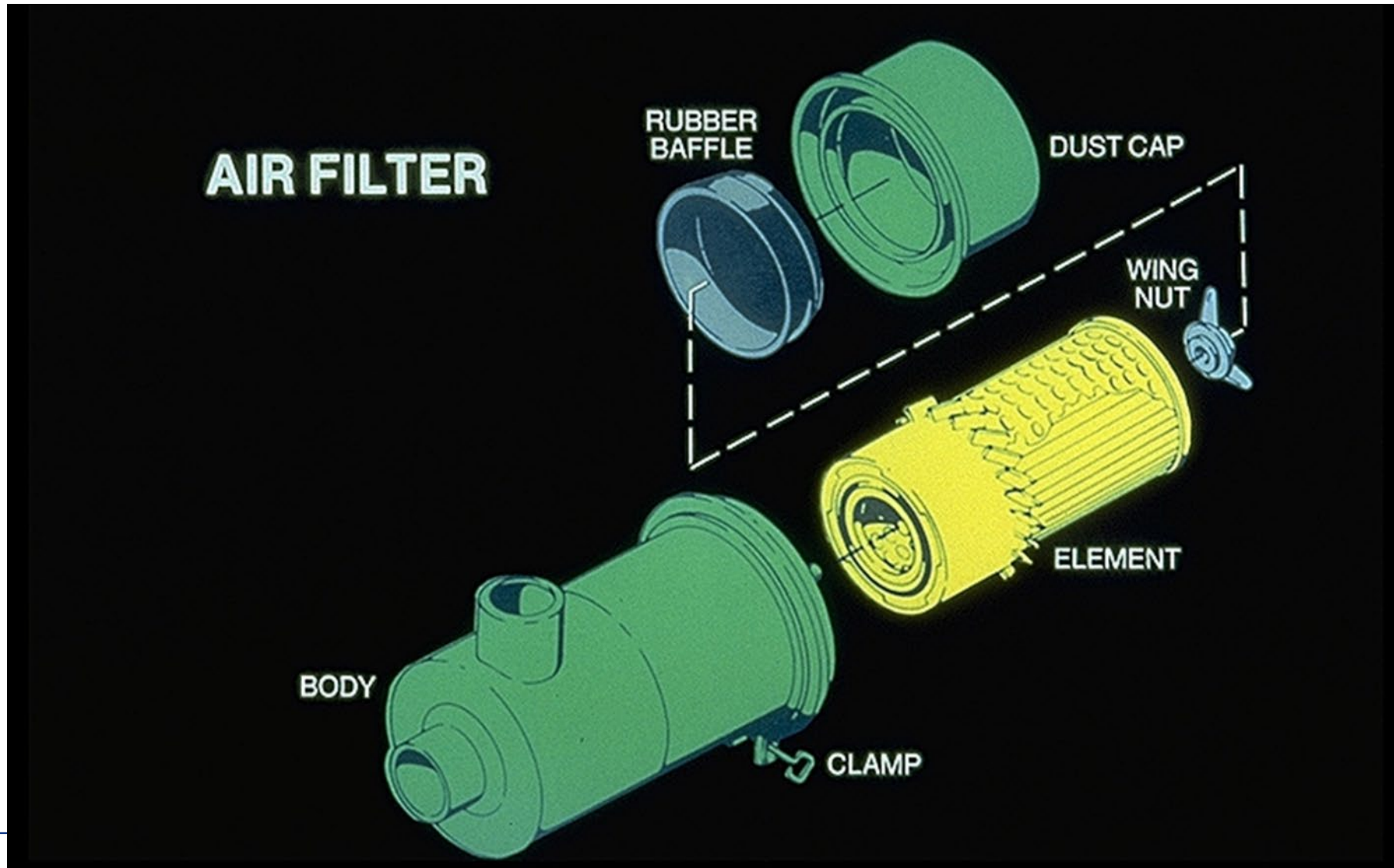

Summary

- The selection of a compressed air dryer should be based on the required pressure dewpoint and ambient conditions.
- Dryer ratings are based upon saturated air at inlet, the geographical location is not a concern.
 - However, the inlet temperature to a dryer is rated at 100F. Higher temperatures will require re-rating of the dryer size.
- Use the correct pre and after filters as applicable. Pressure drop must be taken into account.
- Compressed air should be dried only where necessary and only to the pressure dew point required.
- Compressed air should be filtered only where necessary and only to the quality required for the end use.

Next Week Session 5

➤ **Distribution System**

Pipe sizing

Pipe Material

Correct Layouts

Receiver Tank Locations

Velocity

Pressure Loss

Next Week Session 5 - Distribution System

- The purpose of the distribution system is to ensure the right rate of flow of compressed air, at the right pressure, temperature and quality, for each end use application.
- Where do I place my receiver tanks?

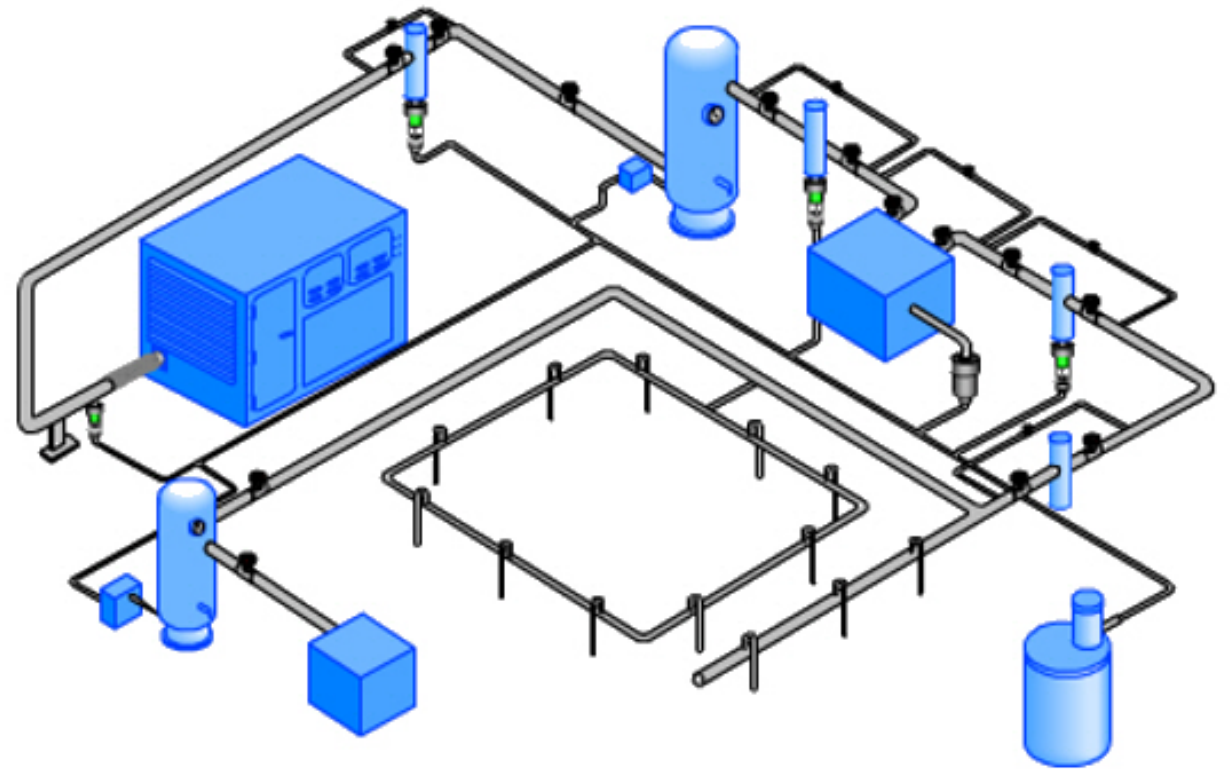

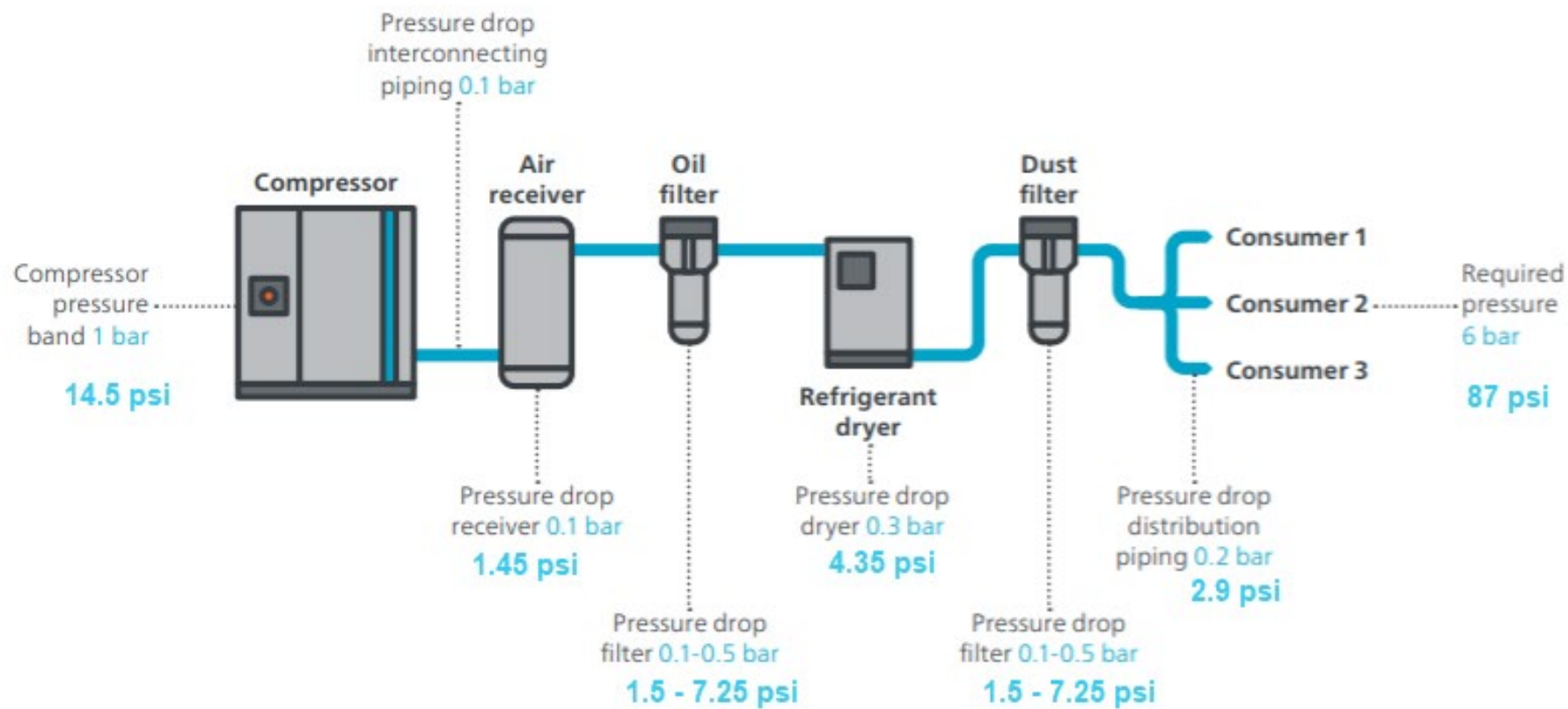

Description	Pressure drop bar(e)
End user	6 87 psi
Final filter	0.1-0.5 1.5 - 7.25 psi
Pipe system	0.3 4.35 psi
Dust filter	0.1-0.5 1.5 - 7.25 psi
Dryer	0.3 4.35 psi
Compressor's regulation range (*)	1 14.5 psi
Compressor max working pressure	7.8-8.6 113.1 - 124.7 psi

Homework for Week 3 – Air Quality

- A factory is located in the Southeast USA. All of piping is located indoors and not subject to freezing temperatures. The compressed air use in the factory is primarily in manufacturing production. What would be the most appropriate type of dryer to use and why?

Homework for Week 3 – Air Quality

- What type of dryer uses a porous material that adsorbs the moisture with compressed air or heat reactivation?

Homework for Week 3 – Air Quality

- What type of dryer uses a drying medium that absorbs the moisture in compressed air?

Homework for Week 3 – Air Quality

- What type of dryer uses a material that allows water vapor to pass through pores faster than other gases thus reducing the water vapor?

Homework for Week 3 – Air Quality

- What type of dryer cools the air to remove the condensed moisture before the air is reheated and discharged?

Homework for Week 3 – Air Quality

- Refrigerated dryer ratings are based on standard dryer inlet conditions. Dryer ratings must be corrected for conditions other than these standard conditions. What are the three temperature conditions an air-cooled refrigerated dryer is rated for?

Homework for Week 3 – Air Quality

- What type of filter can remove oil aerosols?

Questions?