



# In-Plant Trainings

Virtual Platform

Session 2

Compressor Types



# Homework from Session 1

# Homework for Week 1 – Block Diagram

- Draw a block diagram of your compressed air system.
  - No P&ID drawings please.
- Include supply side and demand side if possible.
- Indicate compressor type and horsepower.
- Show dryer type and any filters.

# Homework for Week 1 – Example Diagram

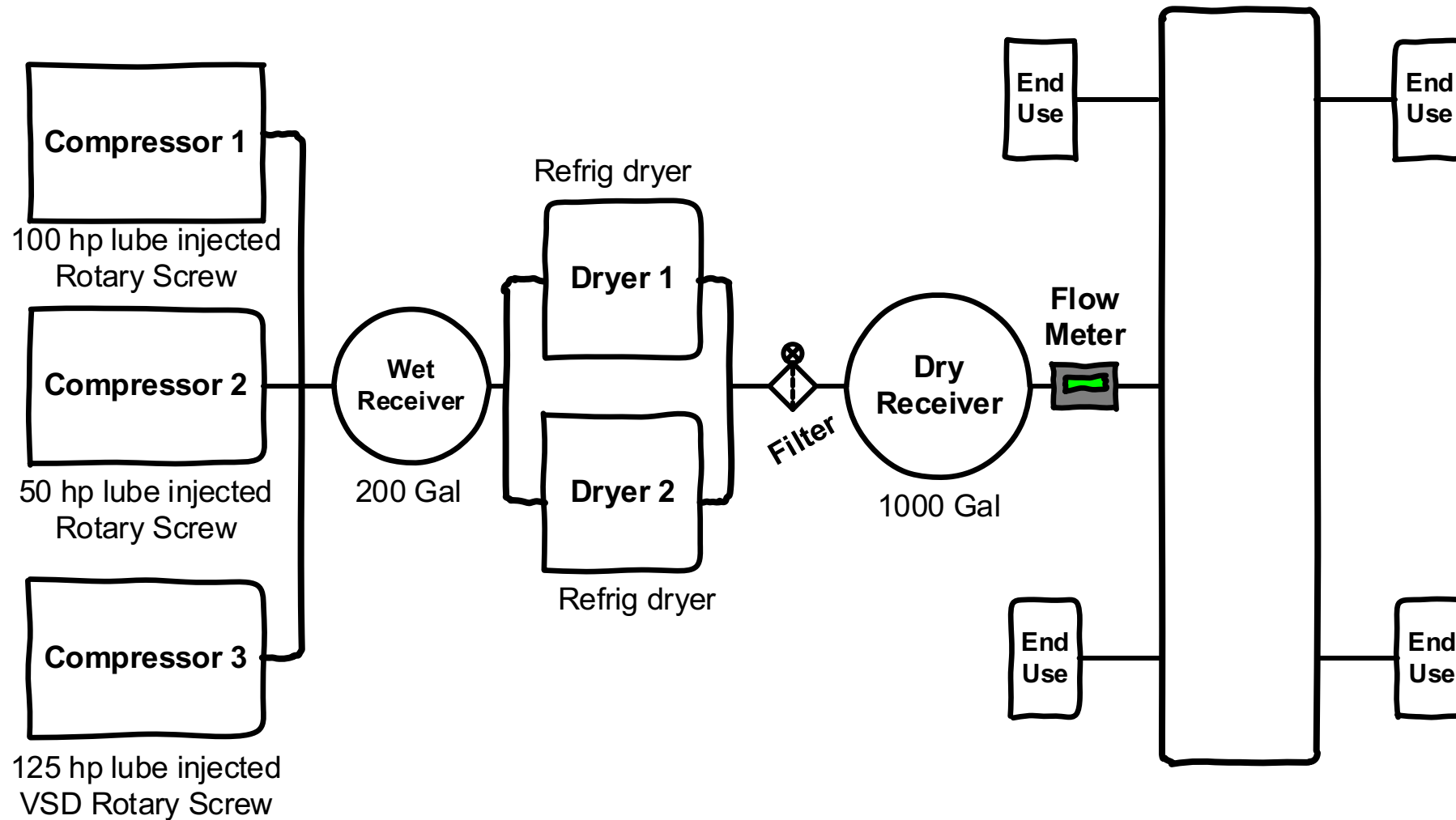

# Homework for Week 1

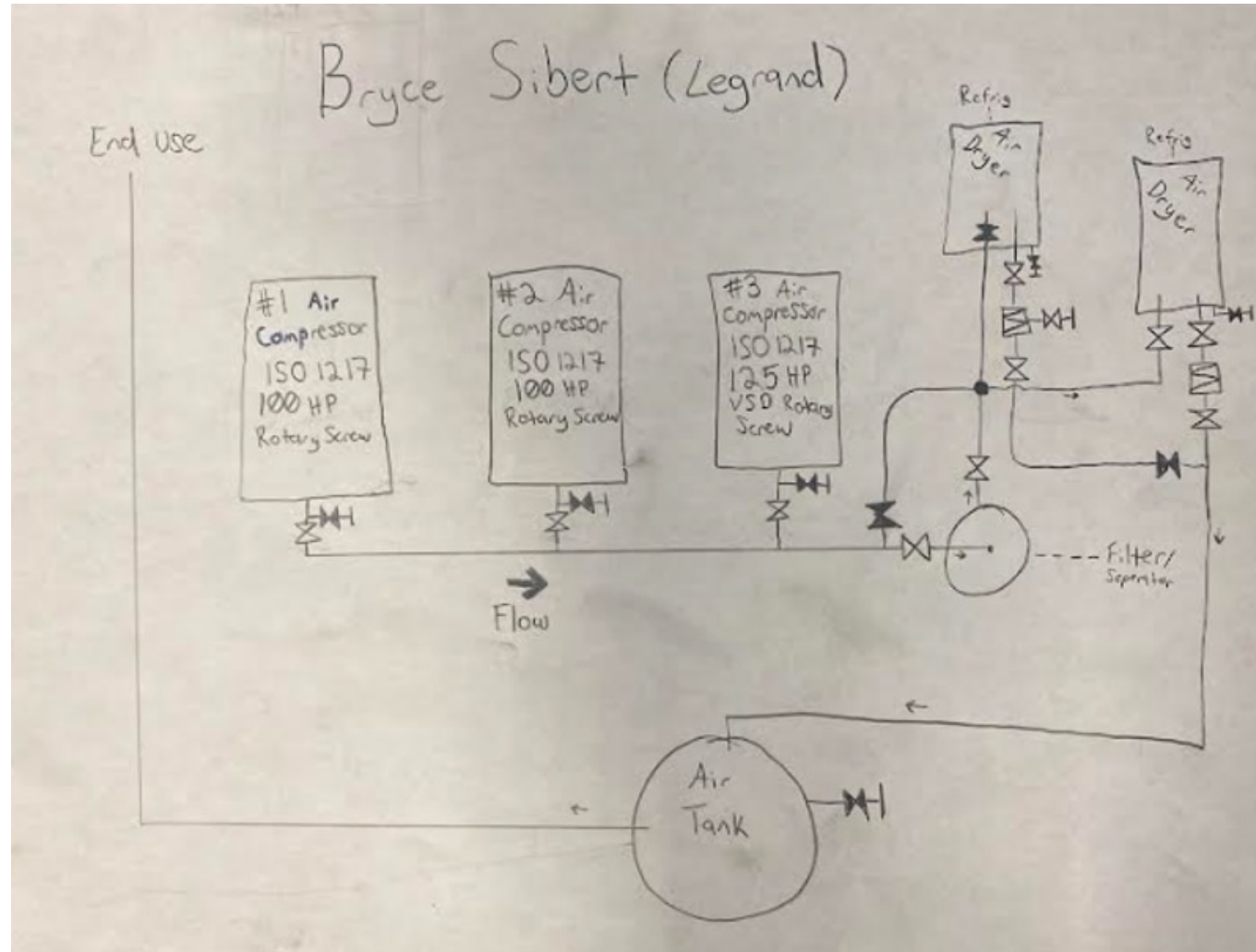

# Homework for Week 1

Number:	Type	Run Hours
Comp. 1	GA45 VSD	103.000
Comp. 2	GA45+	85.500
Comp. 3	GA75	55.000
Comp. 4	GA75 VSD	56.000
Droger 1	FD 450	202.000
Droger 2	FD 510 A	54.000
Filter 1	DD 520 F	220.000
Filter 2	PD 520 F	220.000

**Kadir Demirel**

Werkvoorbereider/Planner  
Maintenance

OwensCorning Apeldoorn | Maintenance

P: +31555386448

M: +31611760267

[kadir.demirel@owenscorning.com](mailto:kadir.demirel@owenscorning.com)



**COMPOSITES**  
Make Impossible Things

Laan van Westenenk 5  
7336 AZ Apeldoorn  
The Netherlands

[www.owenscorning.com](http://www.owenscorning.com)



TM & © 2019 MGM

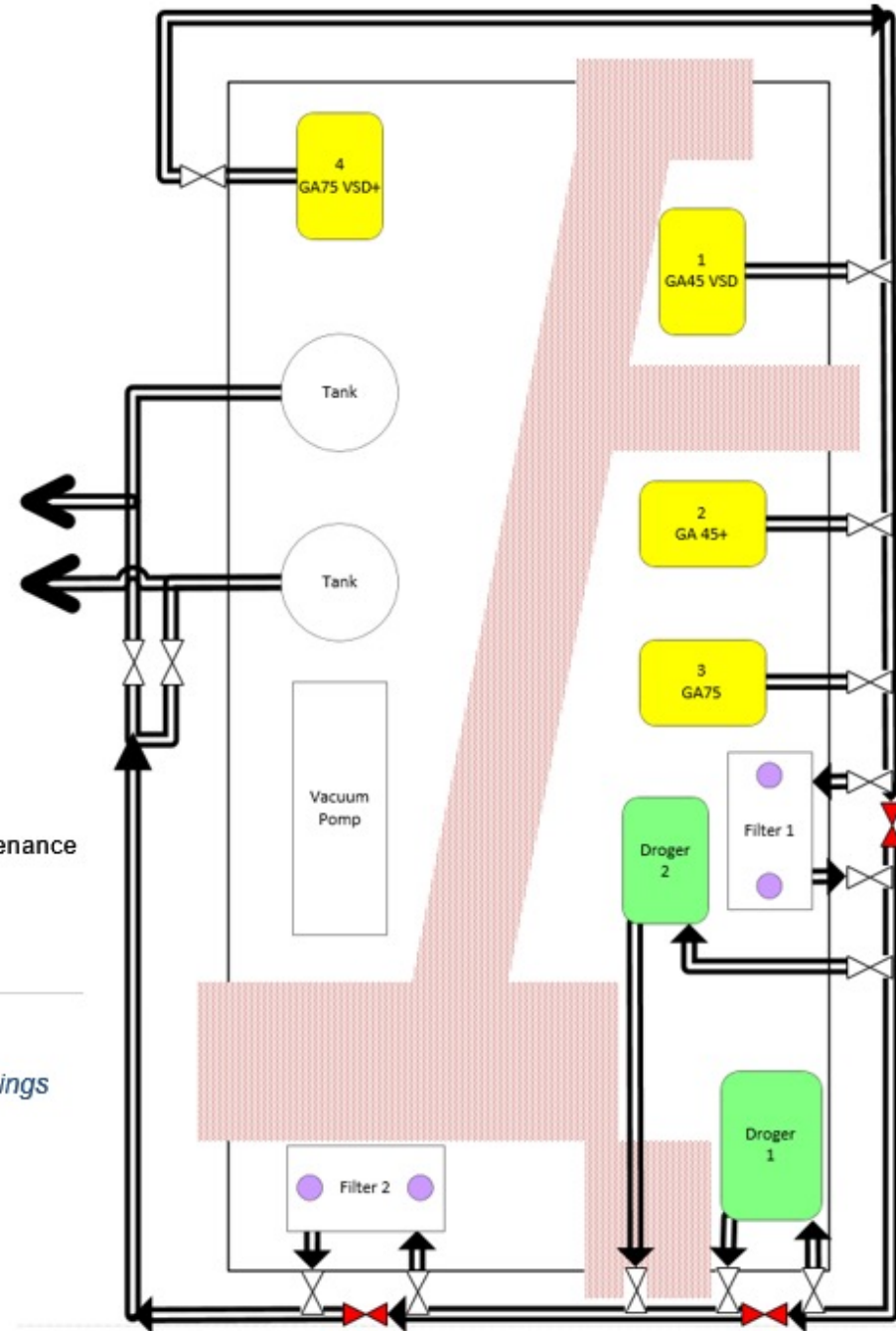

# Homework for Week 1

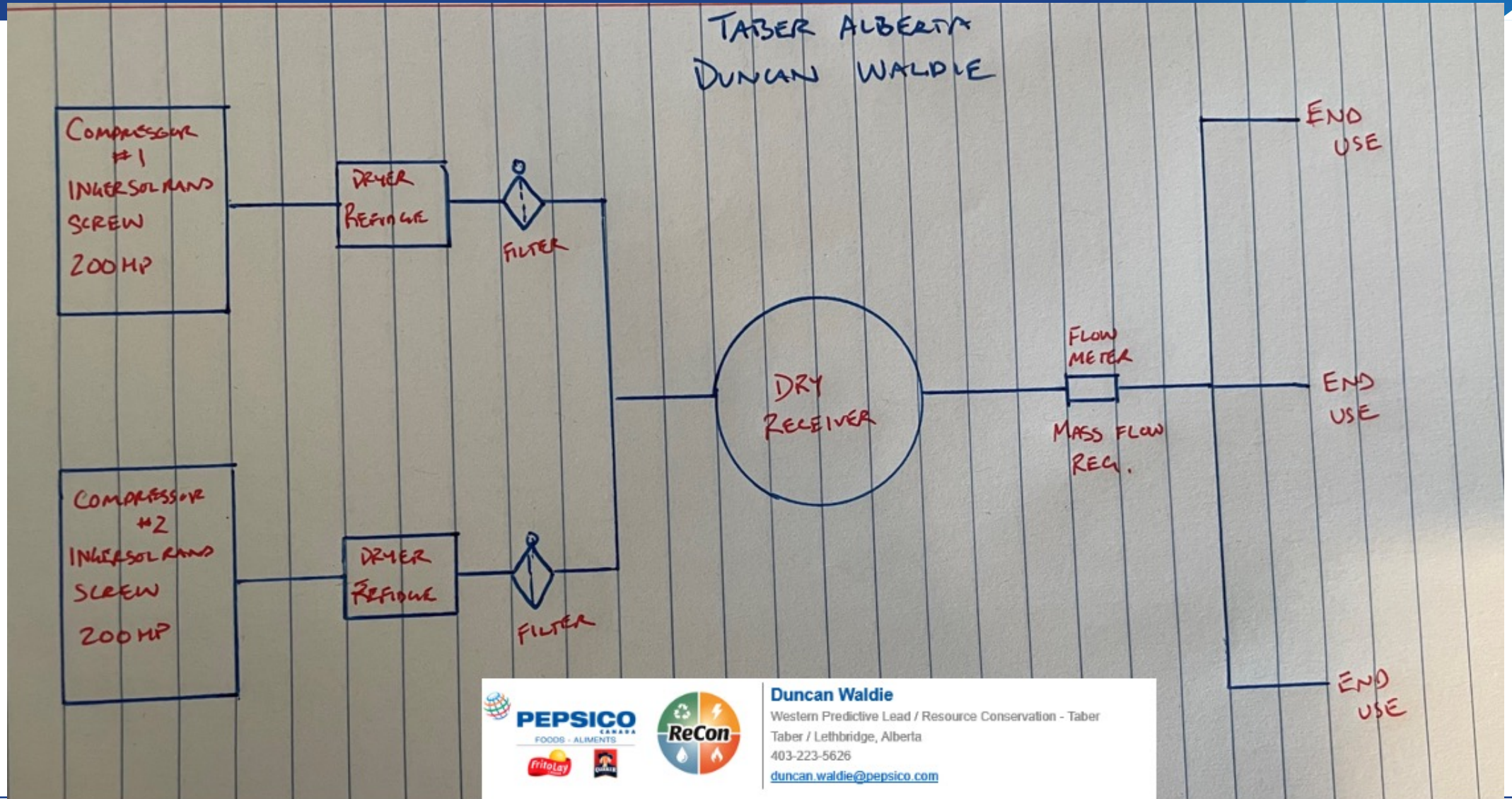

**Duncan Waldie**

Western Predictive Lead / Resource Conservation - Taber

Taber / Lethbridge, Alberta

403-223-5626

[duncan.waldie@pepsico.com](mailto:duncan.waldie@pepsico.com)

# Homework for Week 1 (Bendix 100 psig system)

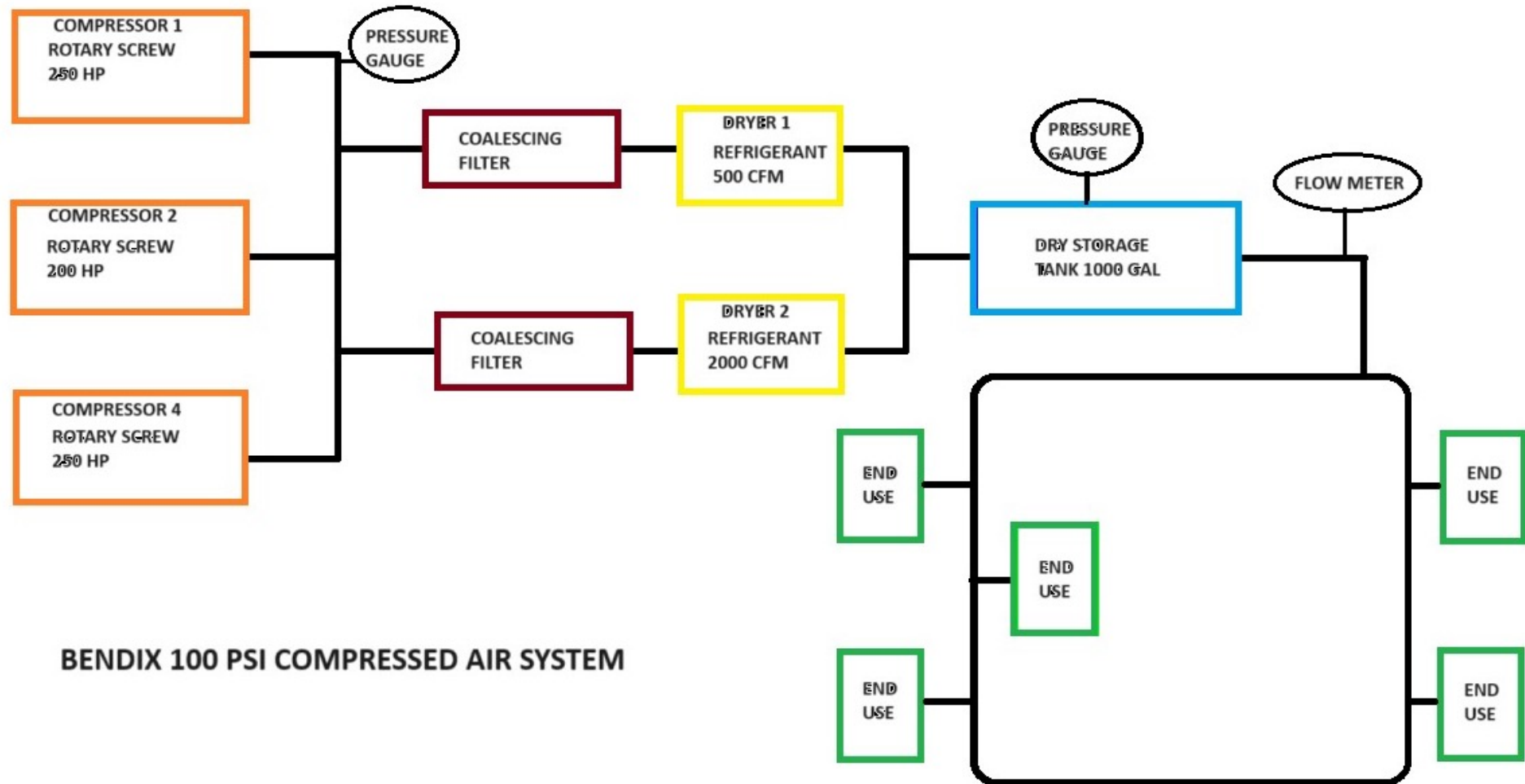



# Homework for Week 1 (Bendix 250 psig system)

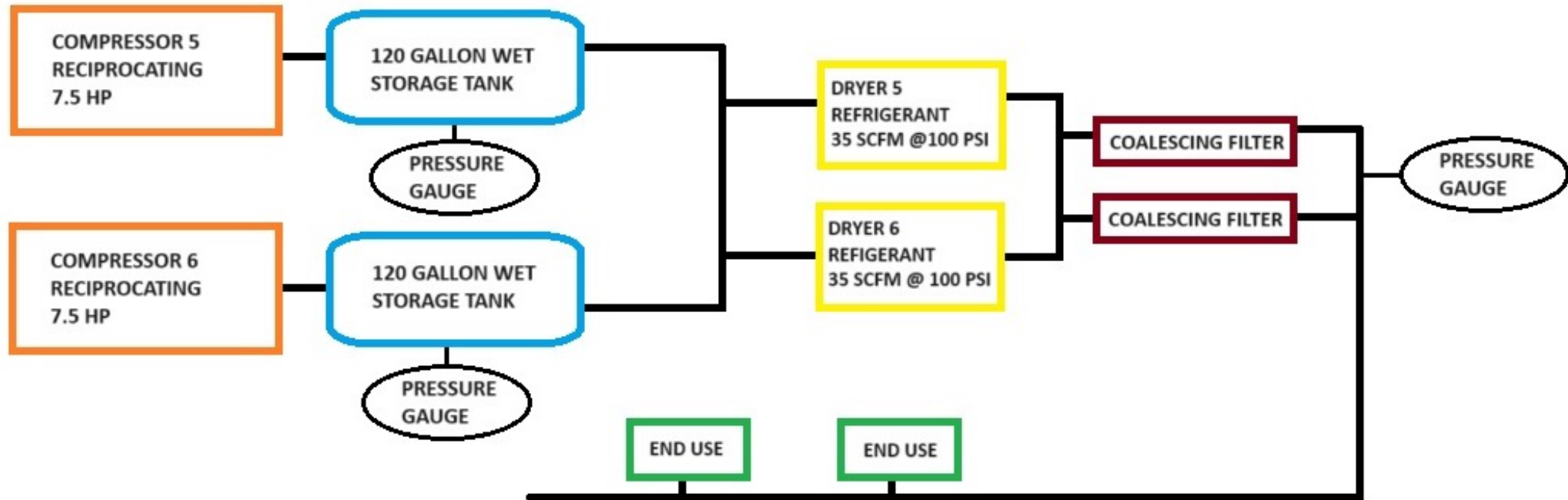

**BENDIX 250 PSI COMPRESSED AIR SYSTEM**

# Homework for Week 1 (Frito Lay)

## Frito-Lay Compressor System Diagram

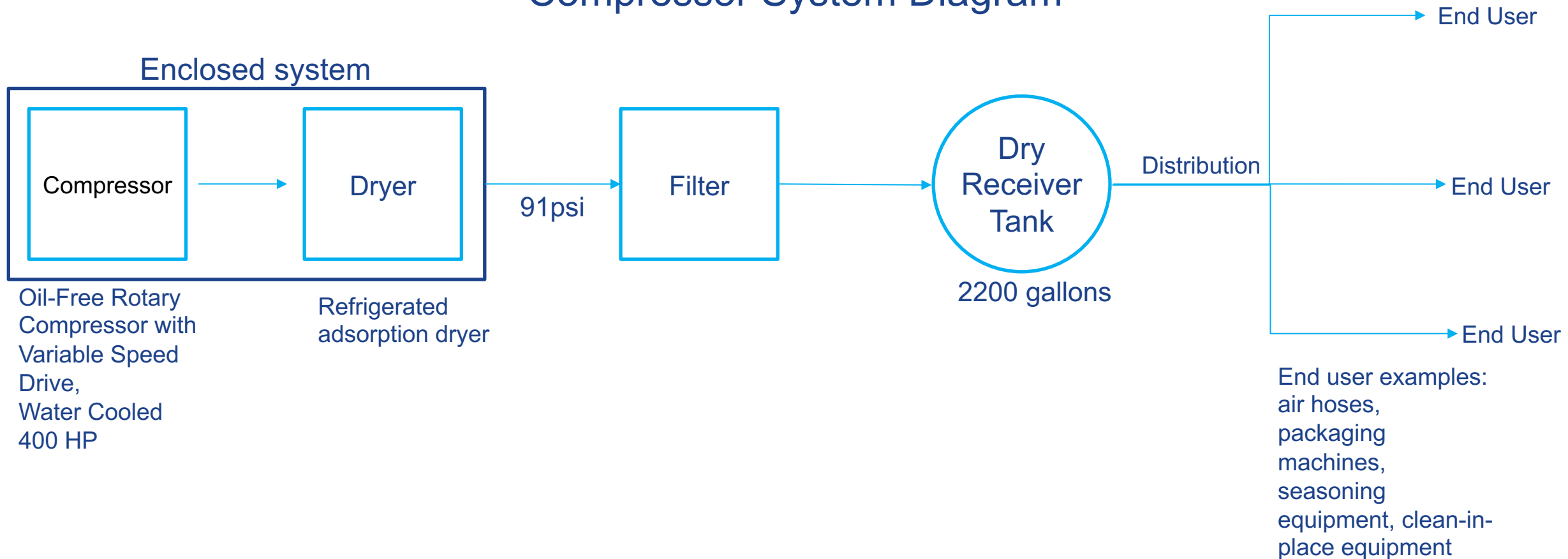

# Homework for Week 1 (Bendix)

## Bill Millsaps

HVAC Technician  
Bendix Commercial Vehicle Systems LLC  
35500 Chester Road  
Avon, Ohio 44011  
Phone: 440-329-9120  
Mobile: 440-420-2856  
[bendix.com](http://bendix.com) • [b2bendix.com](http://b2bendix.com)  
Bendix is growing. [Join Us](#) as we drive the future

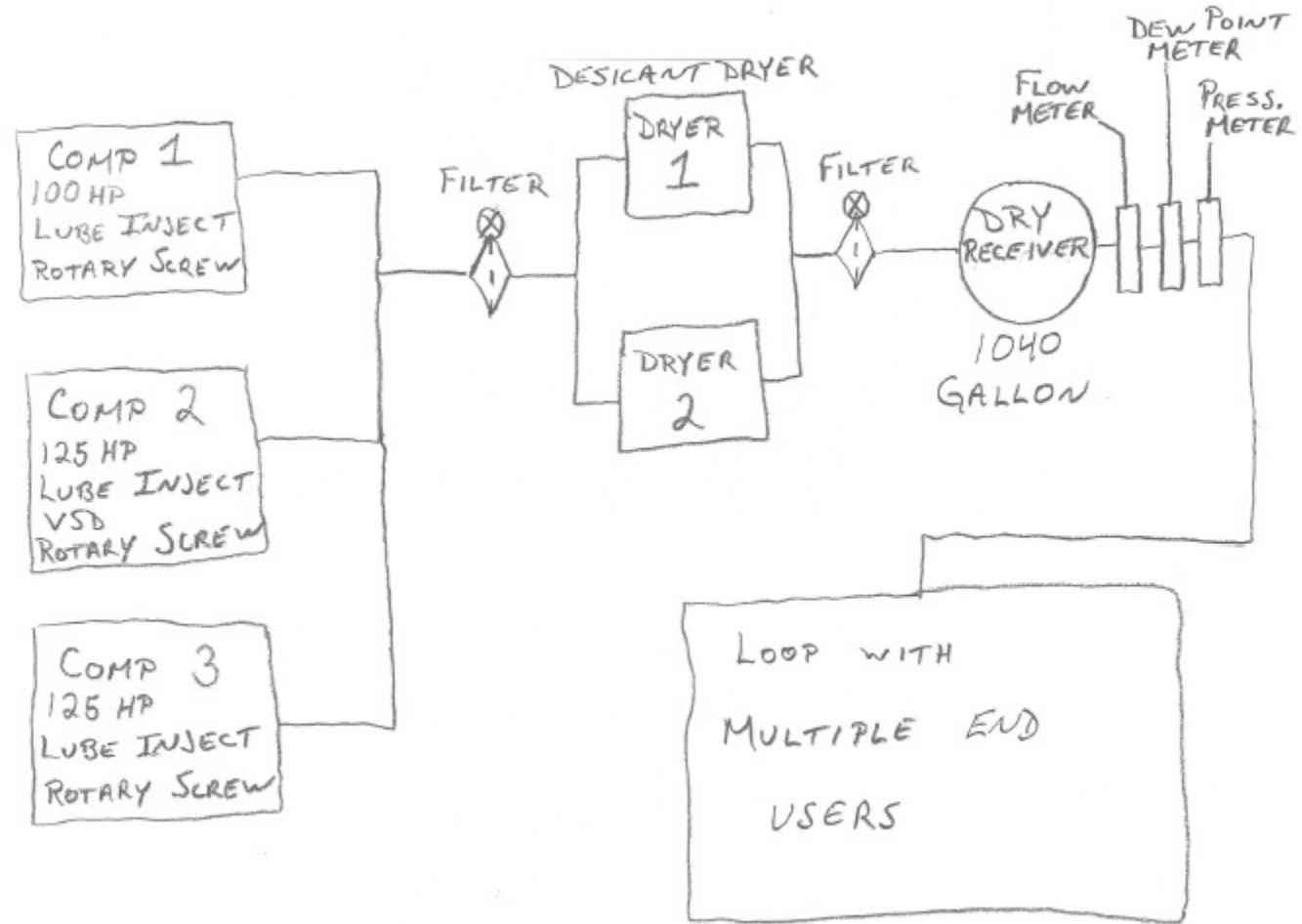



Air Compressor with integrated dryer

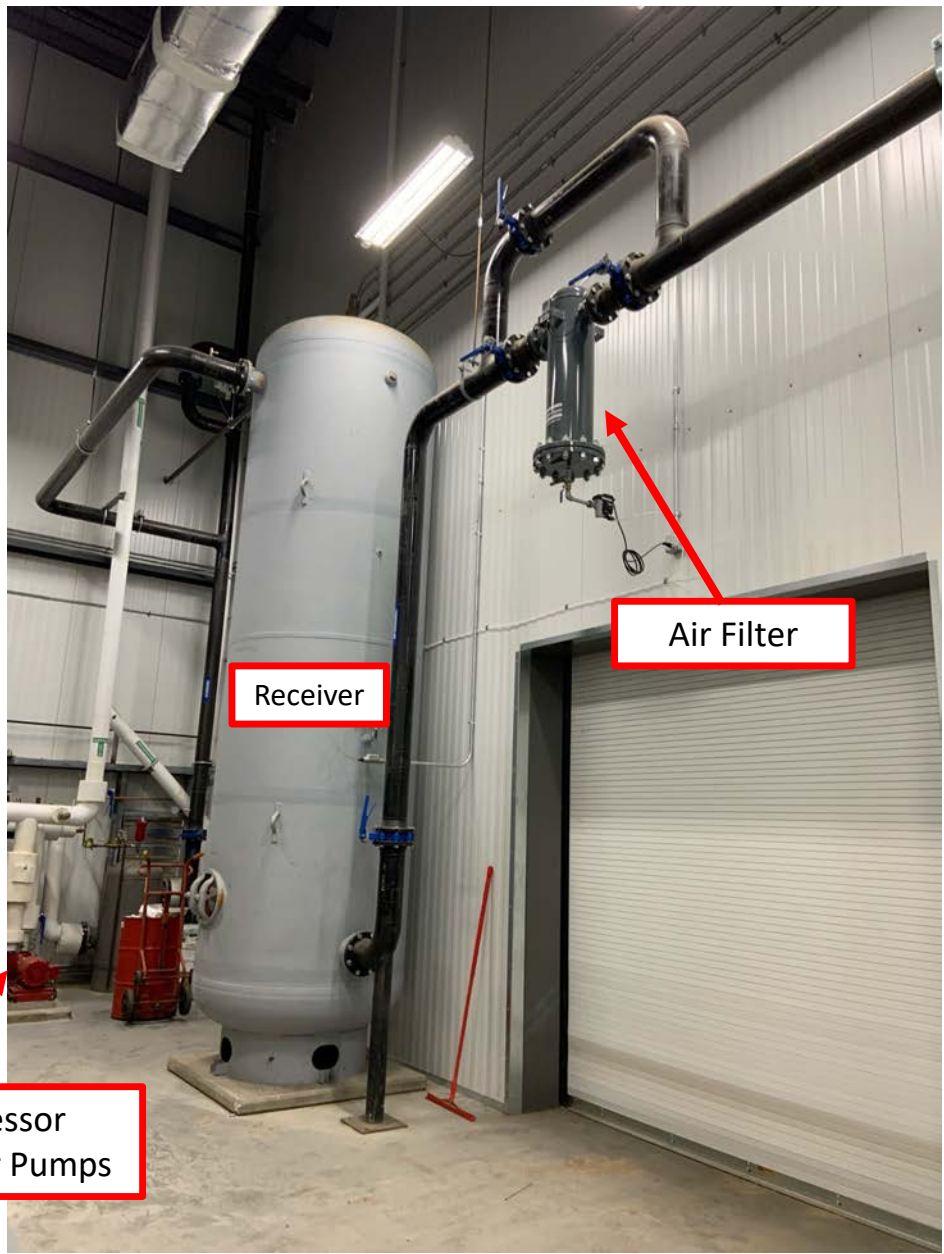

Receiver

Air Filter

Air Compressor Cooling Tower Pumps



Condensate Drain

# Homework for Week 1 (Eastman)

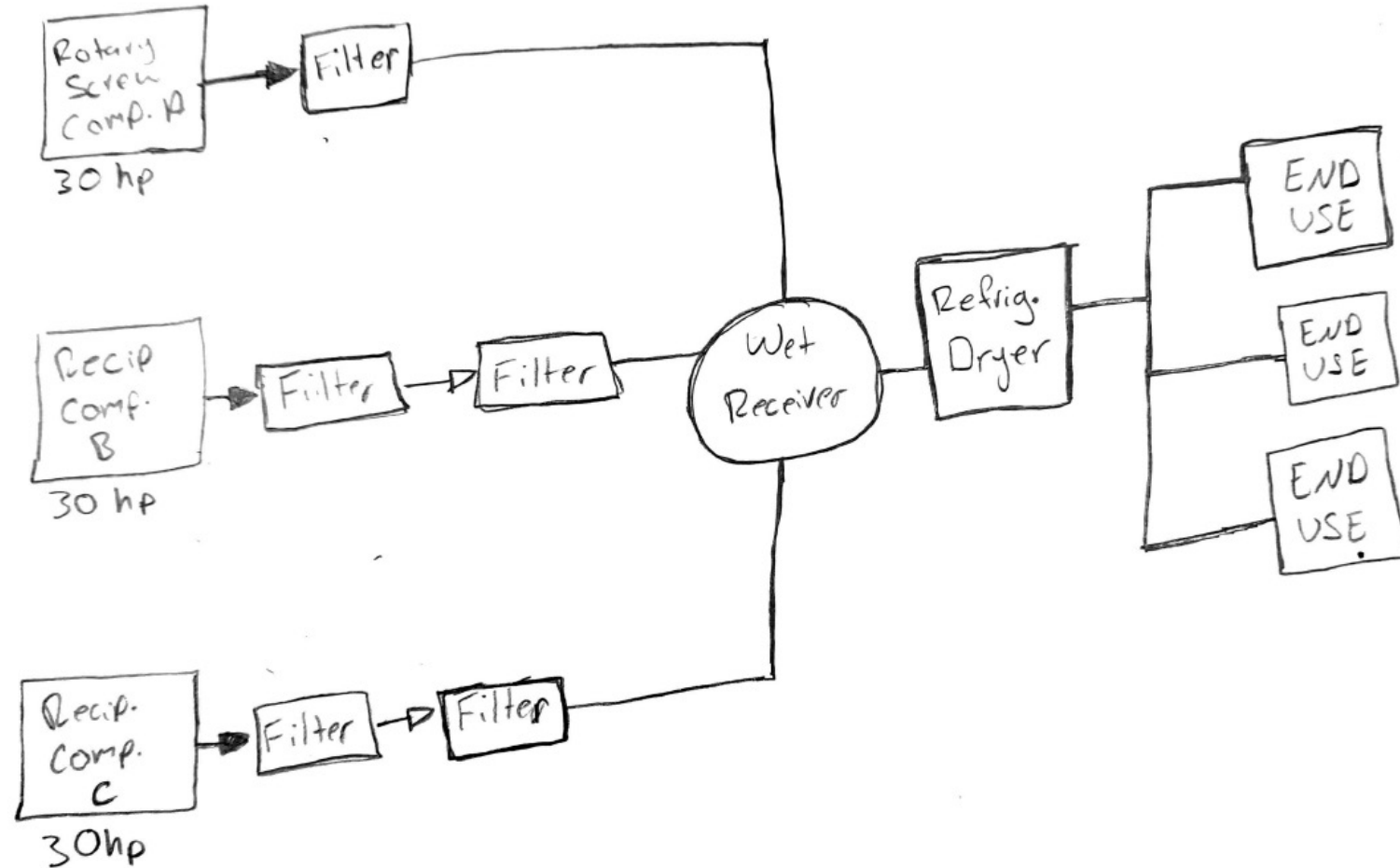

**Makayla Cody | Eastman**  
Plant Engineering Area 4  
Mechanical Engineer  
Office: (423)-229-4052  
Cell: (615)-961-0428

*Makayla Cody - Eastman*

# Air Diagram

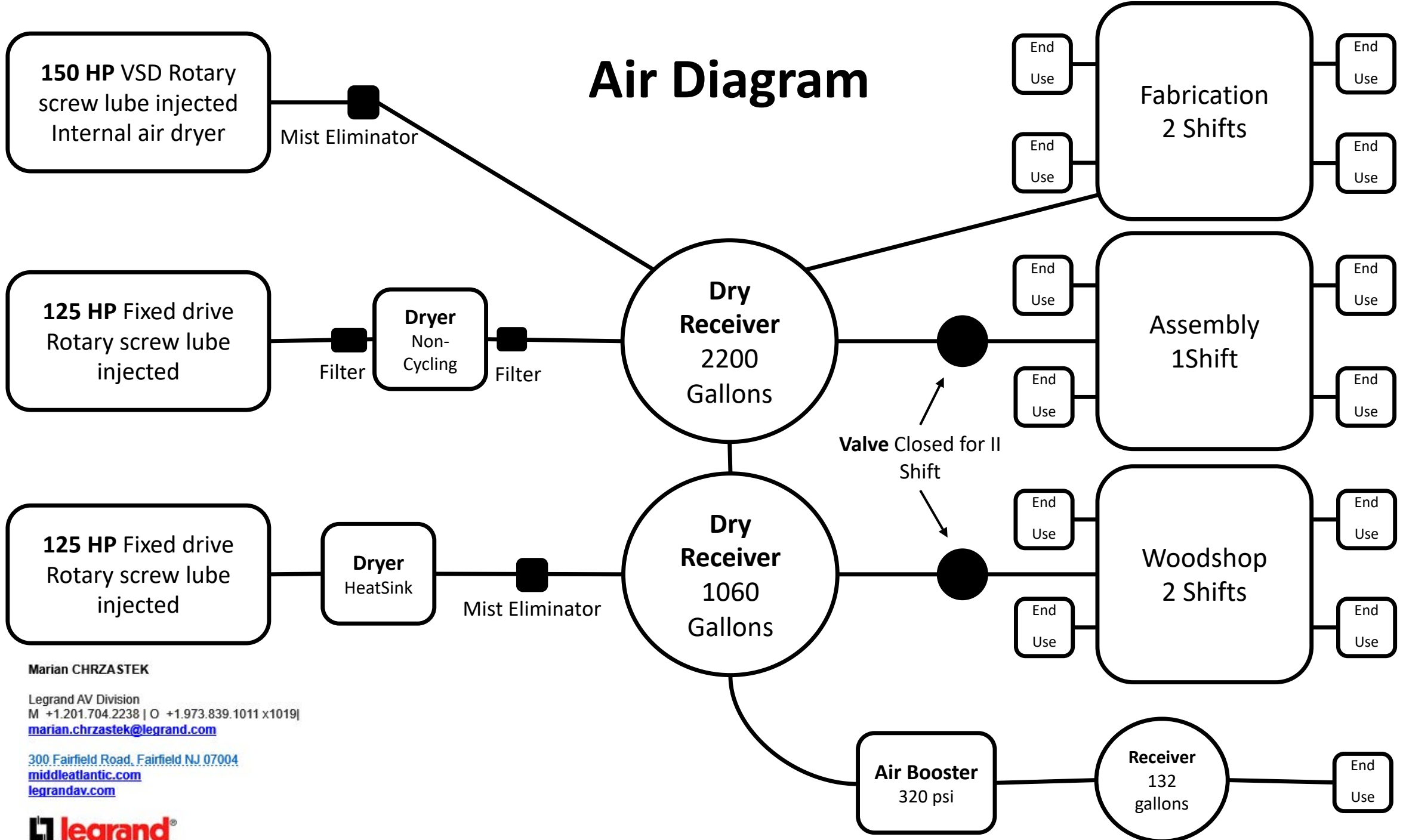

Marian CHRZASTEK

Legrand AV Division  
M +1.201.704.2238 | O +1.973.839.1011 x1019|  
[marian.chrzastek@legrand.com](mailto:marian.chrzastek@legrand.com)

300 Fairfield Road, Fairfield NJ 07004  
[middleatlantic.com](http://middleatlantic.com)  
[legrandav.com](http://legrandav.com)



# Homework for Week 1 (Sun Opta)



**Rustin Fernelius**  
Lead Facilities Maintenance Technician  
320.232.3889 | [rustin.fernelius@sunopta.com](mailto:rustin.fernelius@sunopta.com)  
[www.sunopta.com](http://www.sunopta.com)  
601 3RD AVENUE WEST | ALEXANDRIA, MN 56308

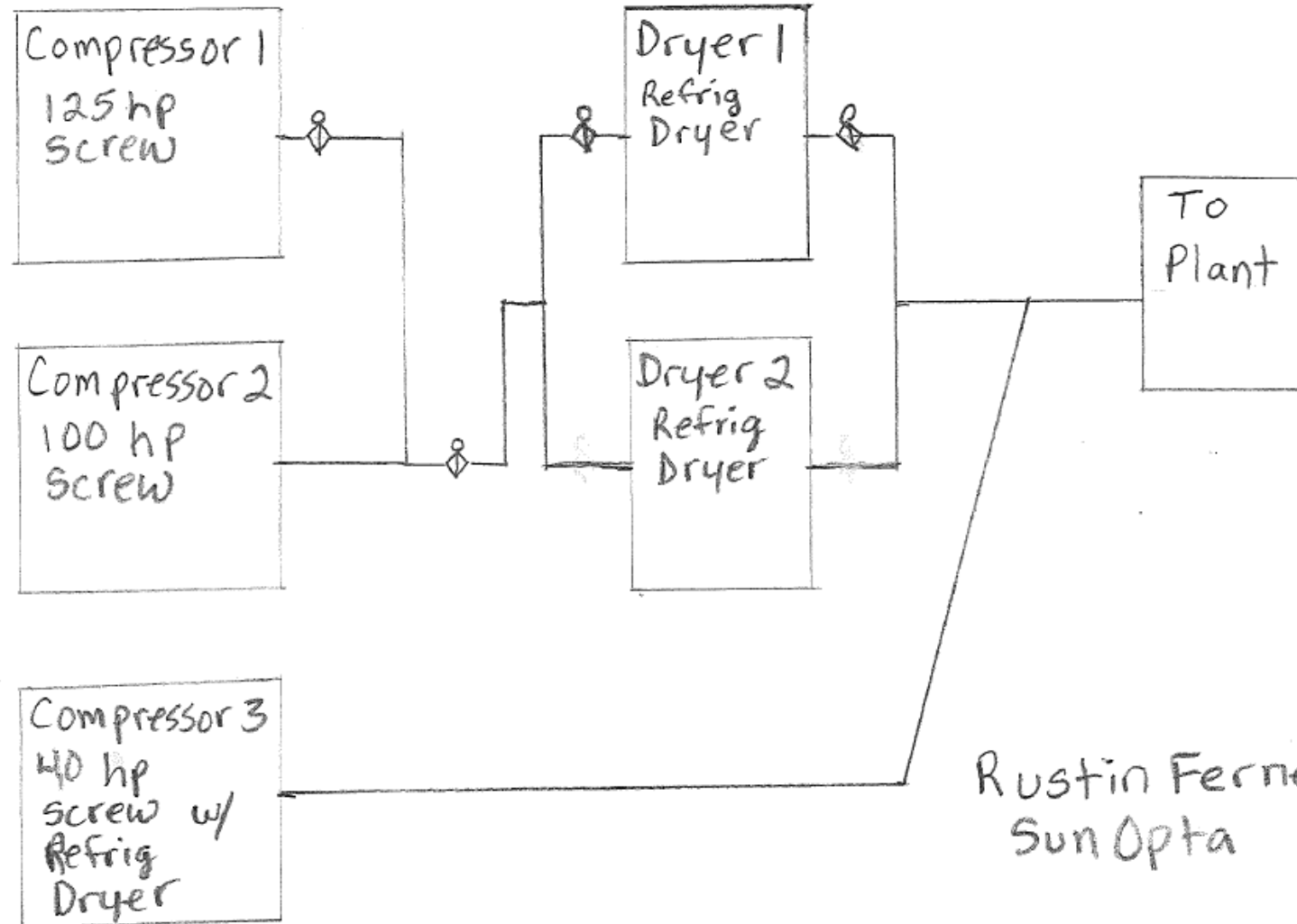

# Homework for Week 1 (Tyson Foods)

## Supply Side

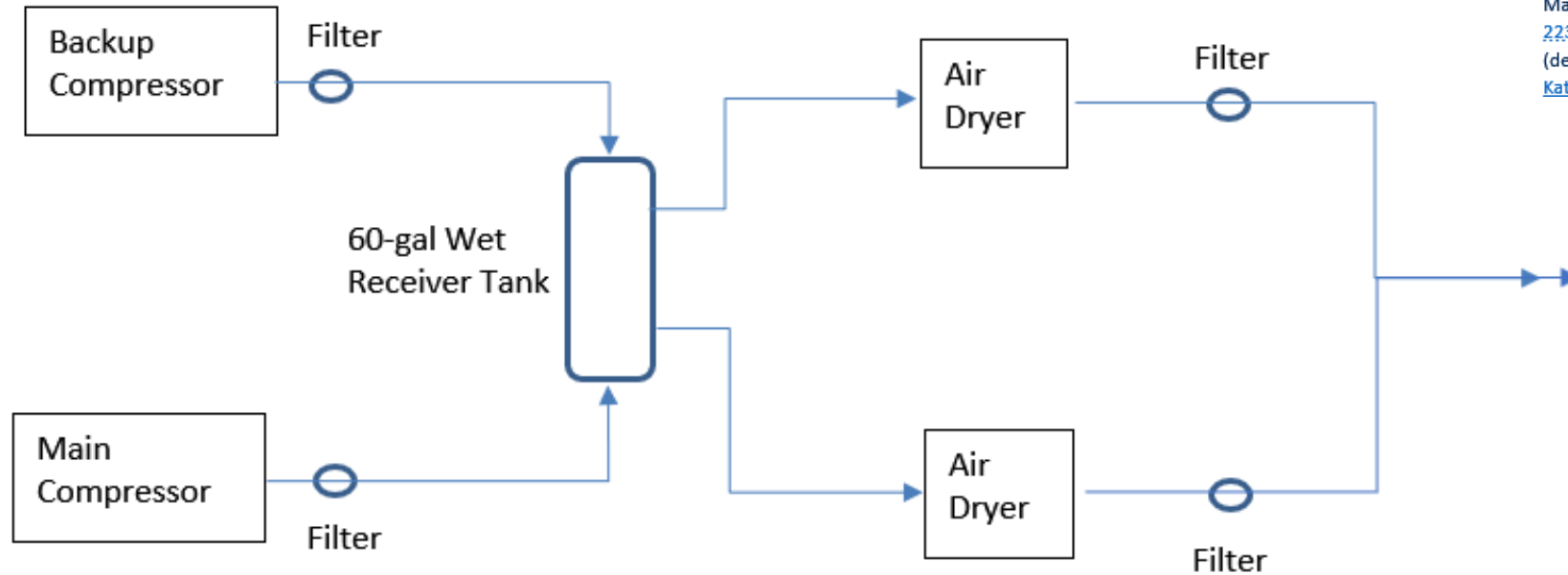

Kathy Nuñez  
Sustainability Engineer IV

Tyson Foods  
Mail Code: AR05835  
[2231 W. Martin Luther King Blvd, Fayetteville, AR 72701](mailto:Kathy.Nunez@tyson.com)  
(desk) 479-290-2210 or (mobile) 479-209-0555  
[Kathy.Nunez@tyson.com](mailto:Kathy.Nunez@tyson.com)

Compressors are individually controlled, with one primary compressor, one backup compressor. The main compressor is a 125 HP variable speed rotary screw air compressor. The backup compressor is a 75 HP rotary screw air compressor. System measures RPM and pressure, but not flow or power. Target system pressure is 126 psi.



# Homework for Week 1 (AUTODIE-LLC)

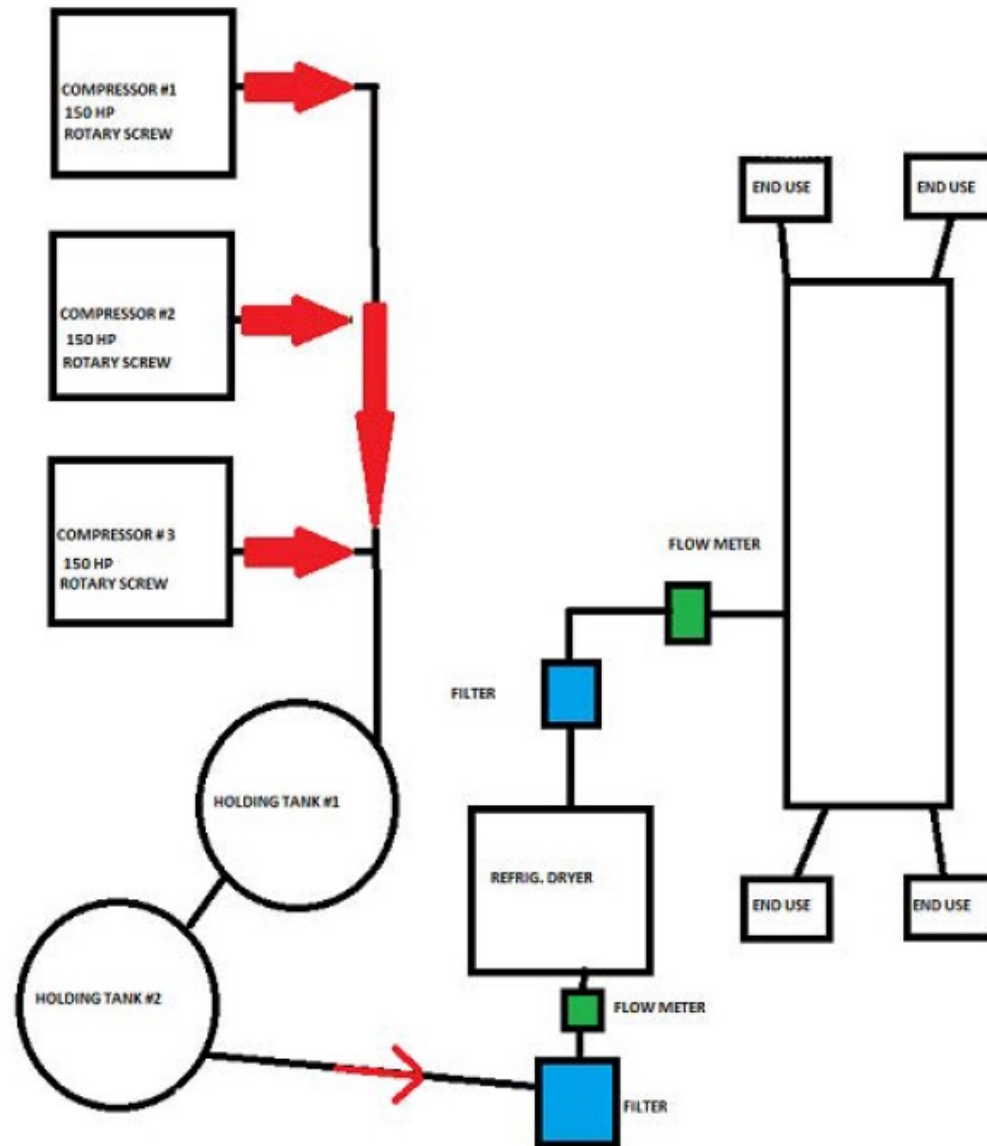

AUTODIE-LLC  
COMPRESSOR SYSTEM

# Homework for Week 1 (International Paper \_Tyson Davis)

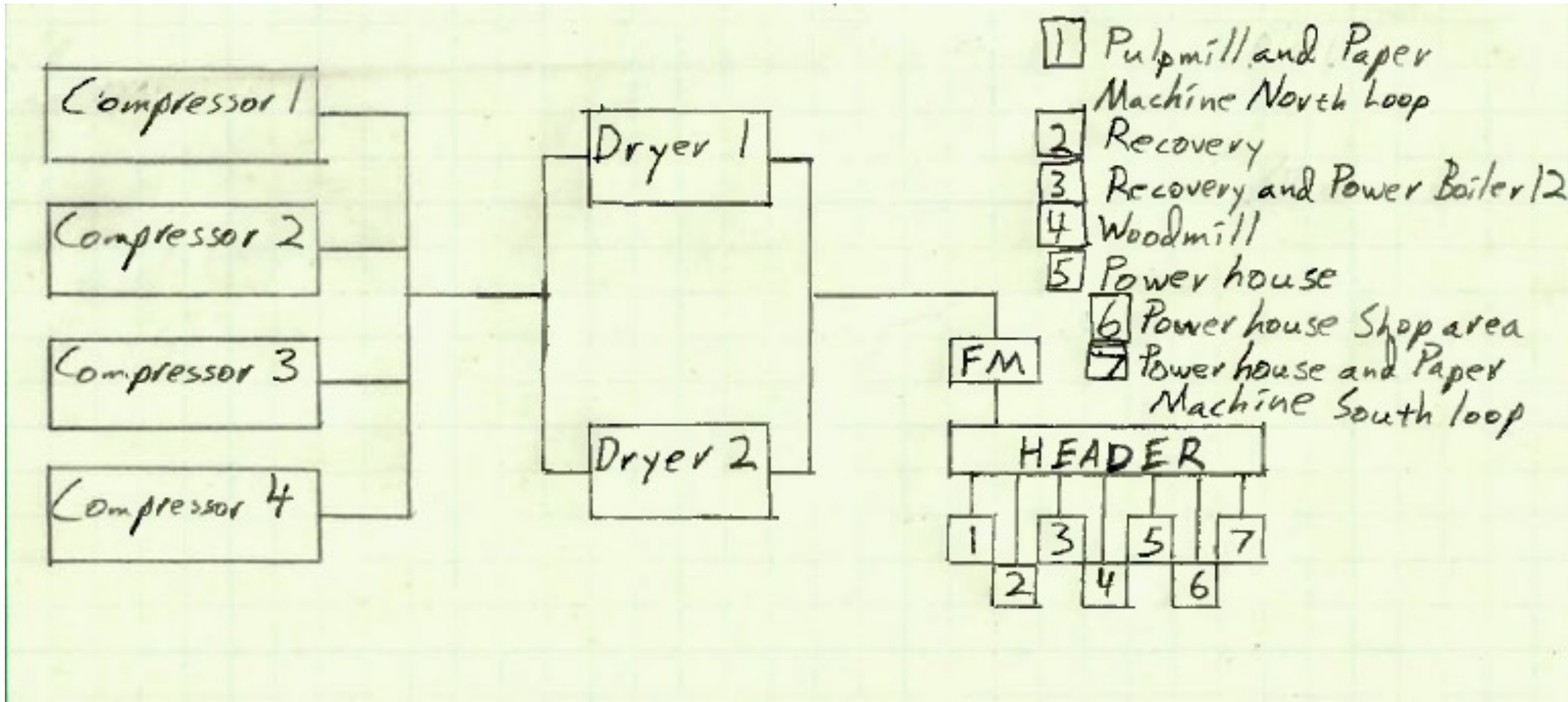

# Homework for Week 1 (International Paper \_Tyson Davis)

- Compressor 1 - 1,000 hp Centrifugal
- Compressor 2 - 1,000 hp Centrifugal
- Compressor 3 - 1,000 hp Rotary Screw
- Compressor 4 - 1,000 hp Rotary Screw

Operating strategy is to run the two centrifugal compressors 24/7 and one rotary screw. Each week, the Mill alternates which rotary screw is on line.

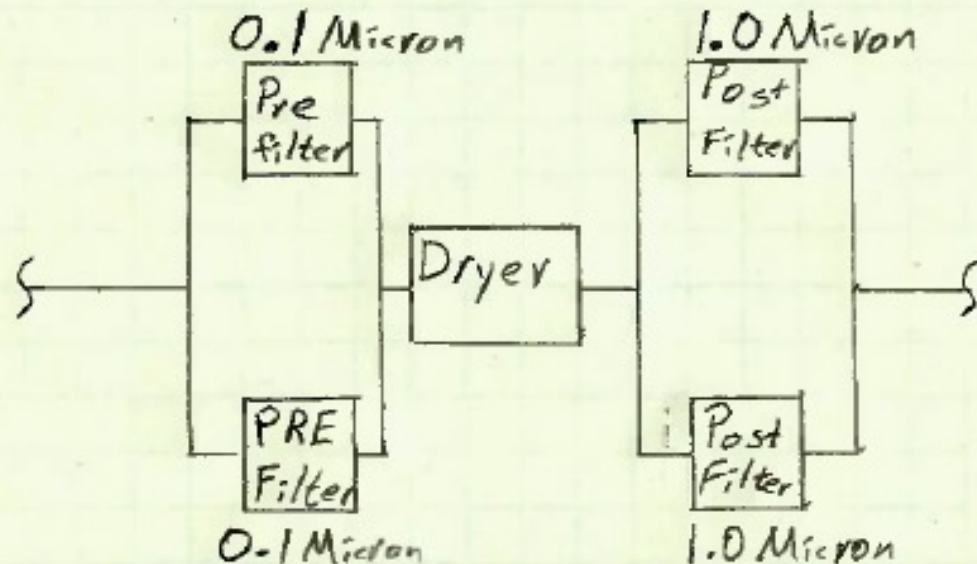

Typical Dryer/Filter Assembly

# Homework for Week 1 (GE Aerospace-Brian Leigh)

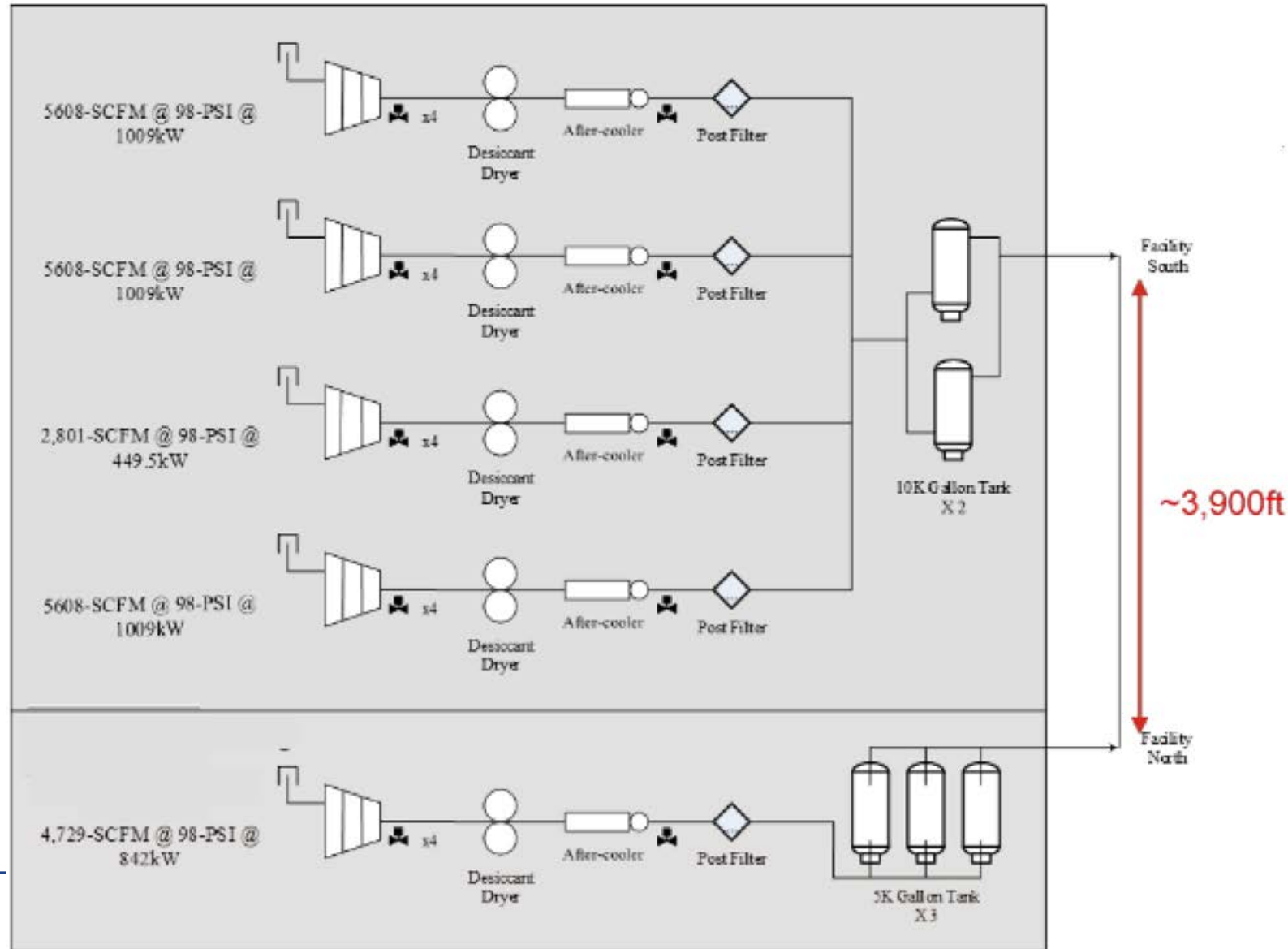

# Homework for Week 1 (Pepsico - Michelle Dunbar)

## PepsiCo Lethbridge Compressor Layout

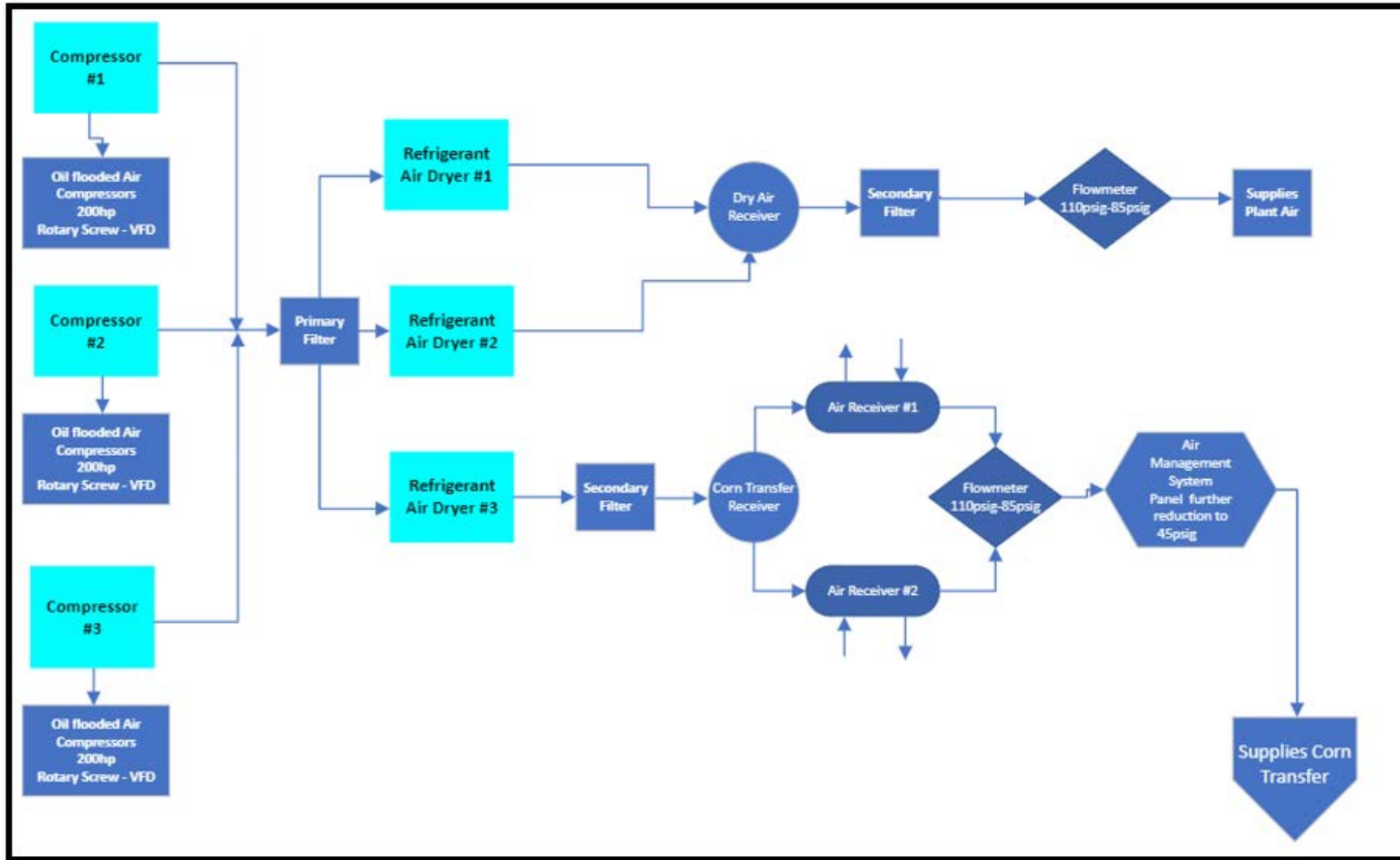

# Homework for Week 1 (GE Aviation CMC)

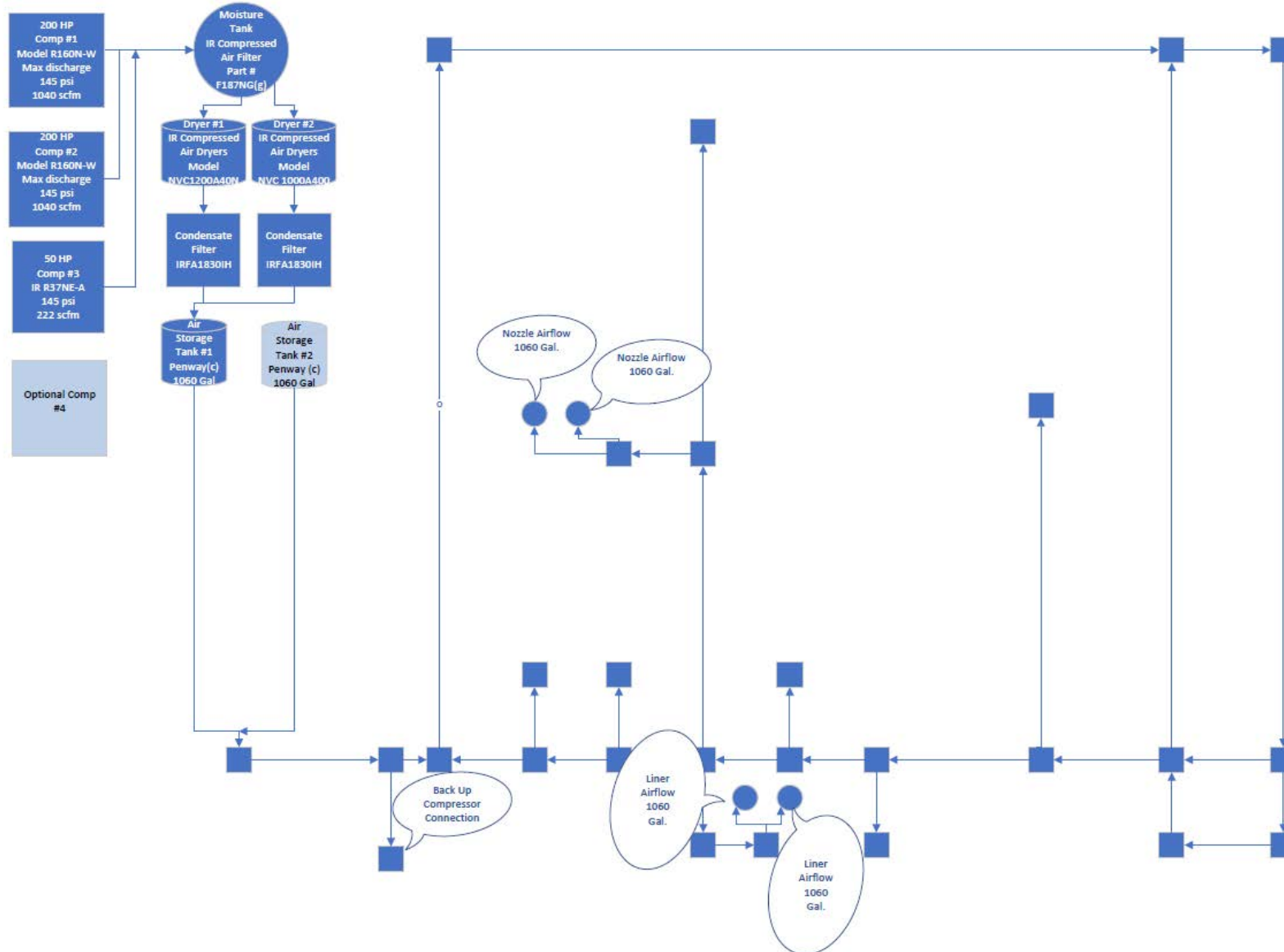

Brett Sanford  
Facilities Engineering Specialist  
GE Aviation CMC  
[502 Sweeten Creek Industrial Park](#)  
[Asheville, NC 28803](#)  
[Brett.sanford@ge.com](mailto:Brett.sanford@ge.com)

# Homework for Week 1 (Cleveland - Cliffs)

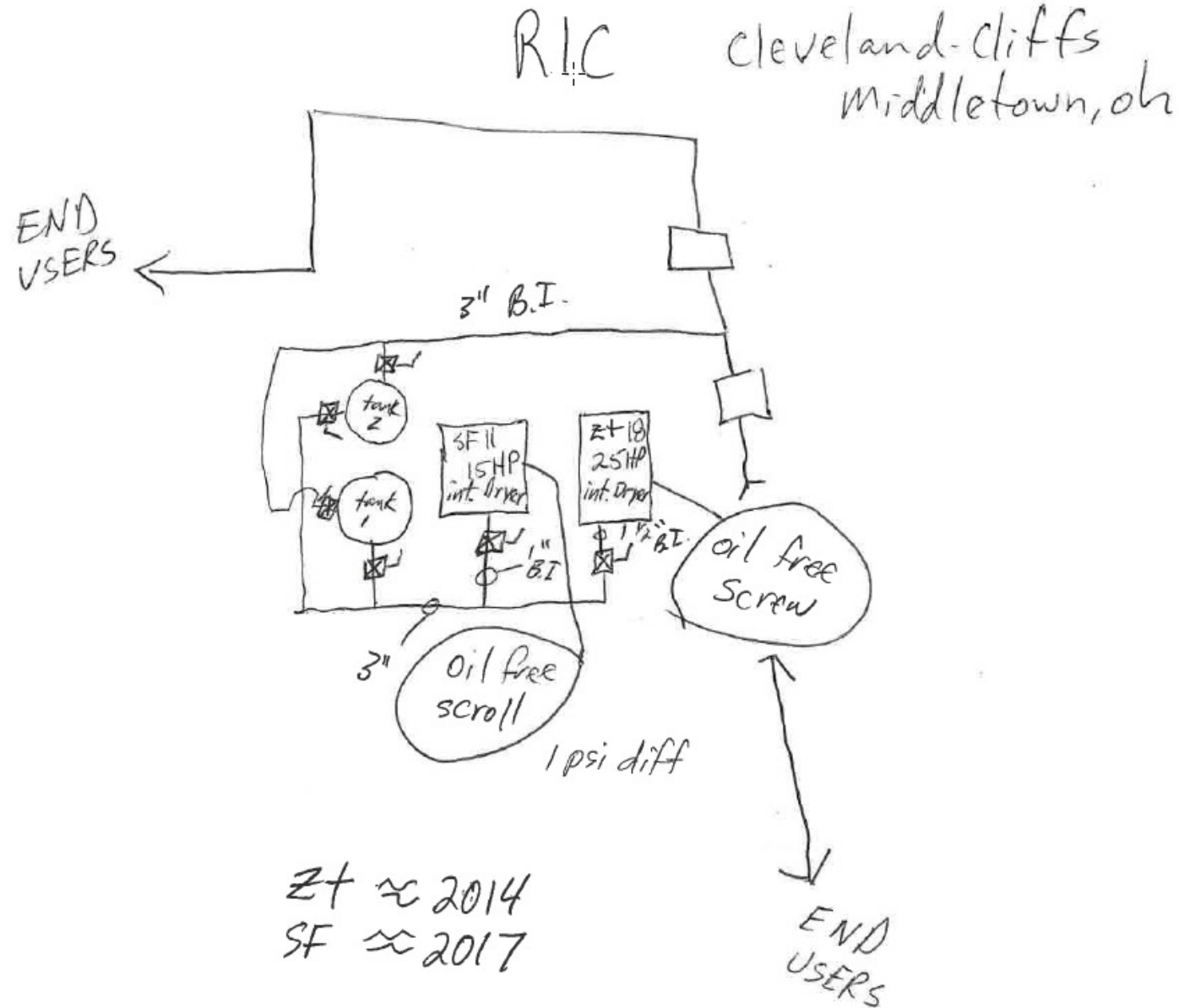

**PAUL GOODWIN**

Electrical Maintenance Technician

P 513-425-5792 M 513-464-7994

[paul.goodwin@clevelandcliffs.com](mailto:paul.goodwin@clevelandcliffs.com)

**CLEVELAND-CLIFFS STEEL CORPORATION**

Research and Innovation Center

6180 Research Way, Middletown, OH 45005

[clevelandcliffs.com](http://clevelandcliffs.com)

# Homework for Week 1 (Toronto Water)

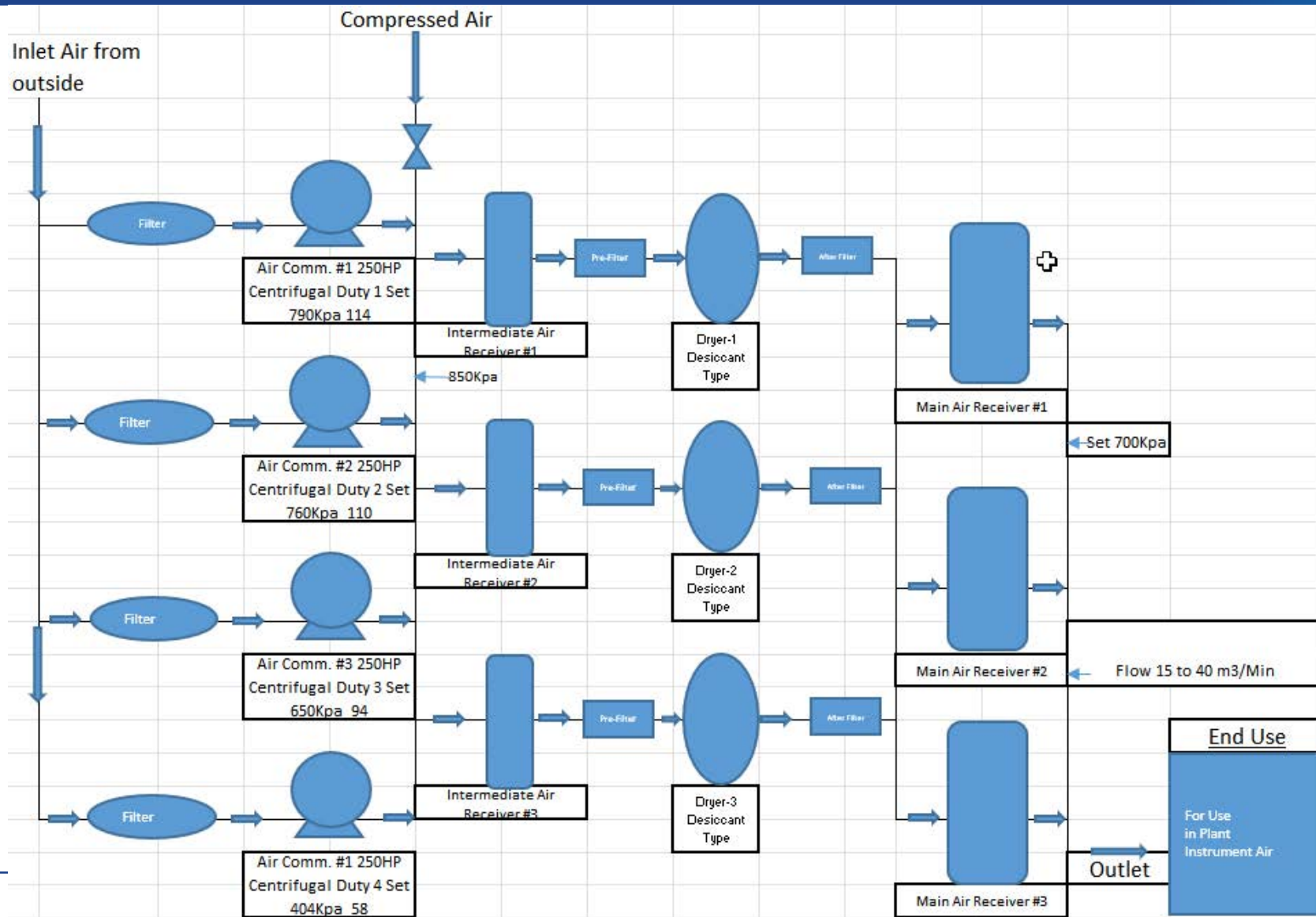

Anand Siva  
 Chief Engineer  
 Toronto Water  
 Ashbridges Bay Treatment Plant  
 9 Leslie Street Toronto ON M4M 3M9  
 Email : [anand.siva@toronto.ca](mailto:anand.siva@toronto.ca)  
 P- 416-392-5156  
 C - 647-881-3336





# Homework for Week 1 (Imco – David Vaneaton)

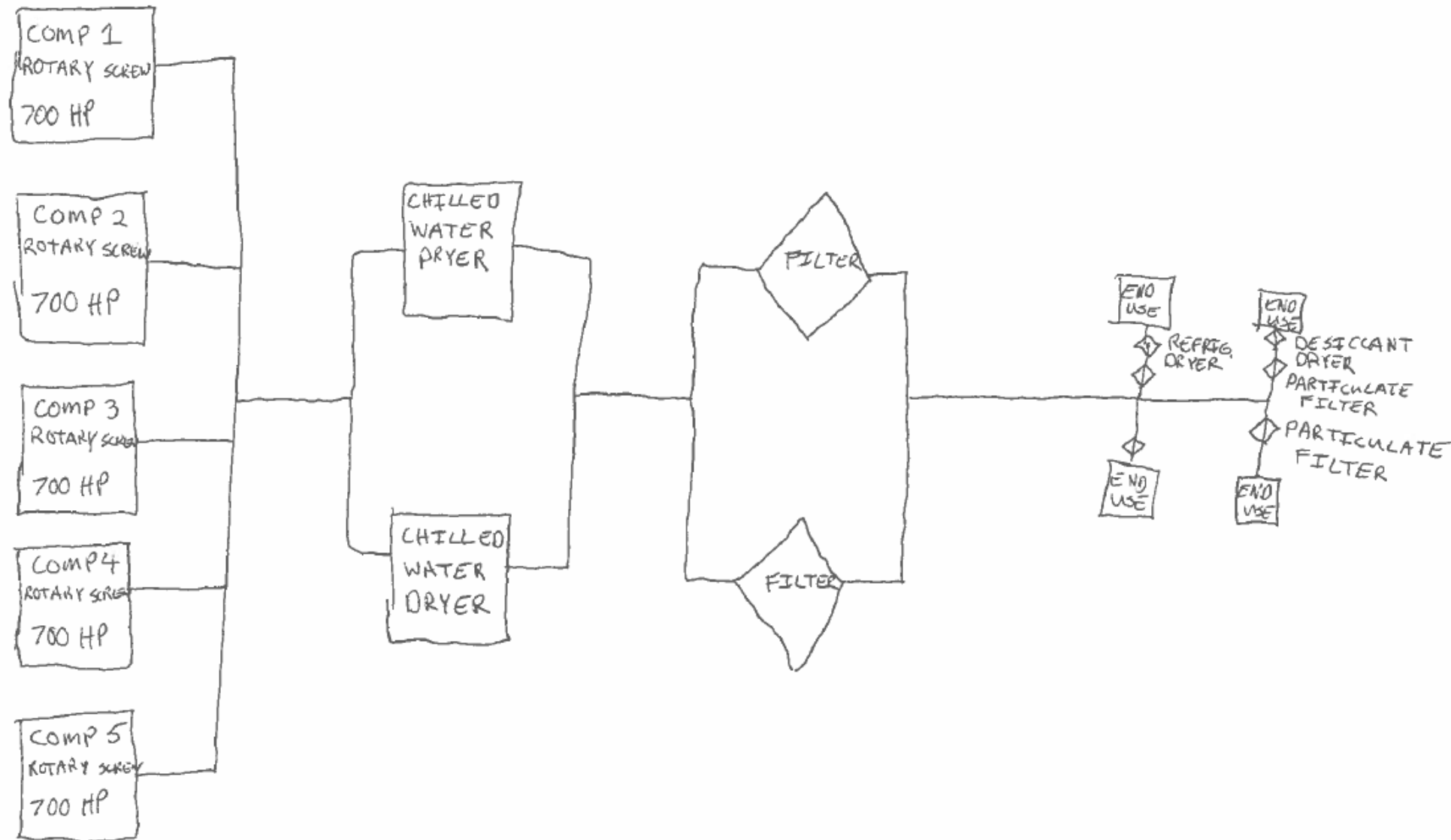

# Compressor Types

# Compressor Types

Two types of compressors:

- Positive Displacement – Typically Rotary Screw
- Dynamic Compressors – Typically Centrifugal

# Compressor Types

- Positive displacement compressors can be reciprocating or rotary.

- Reciprocating Compressor



- Rotary Compressor



# Compressor Types

- Dynamic compressors can be axial or centrifugal.
- Axial Compressor

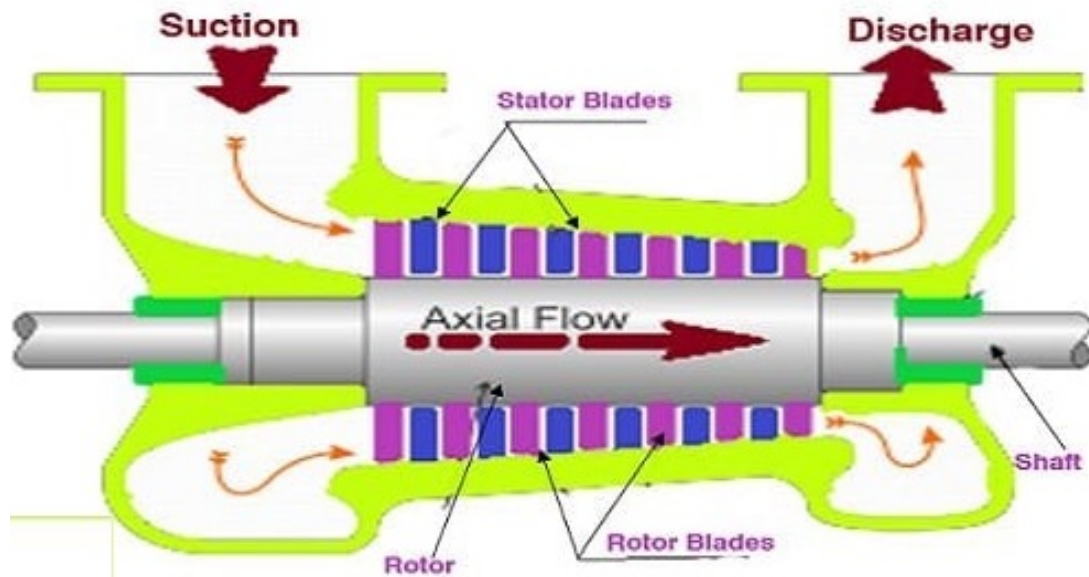

## Centrifugal Compressor

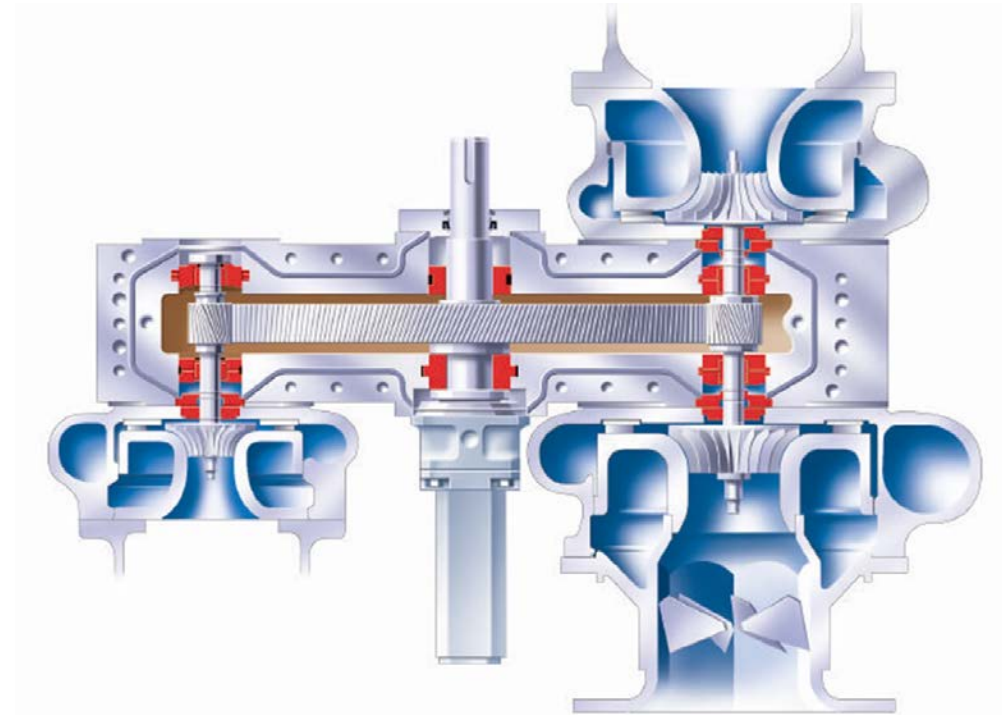

# Other Types of Compressors

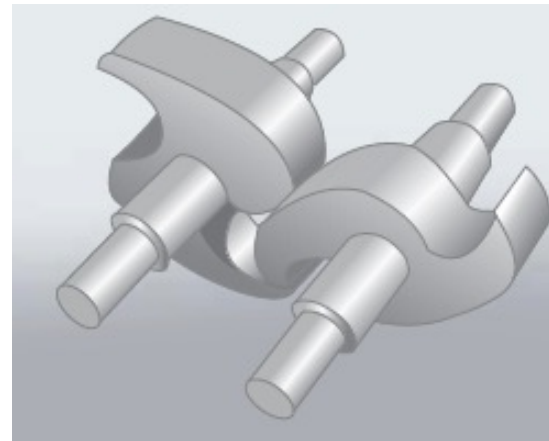
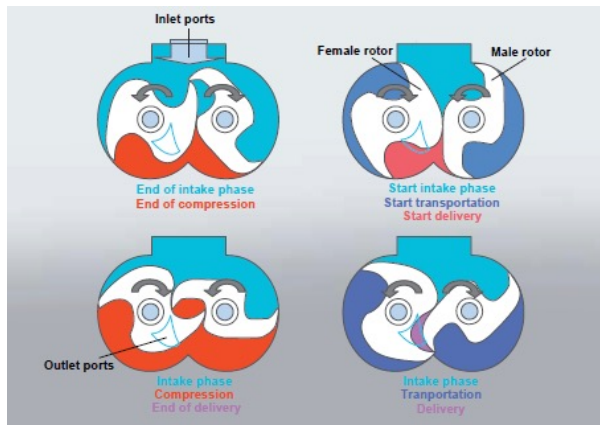
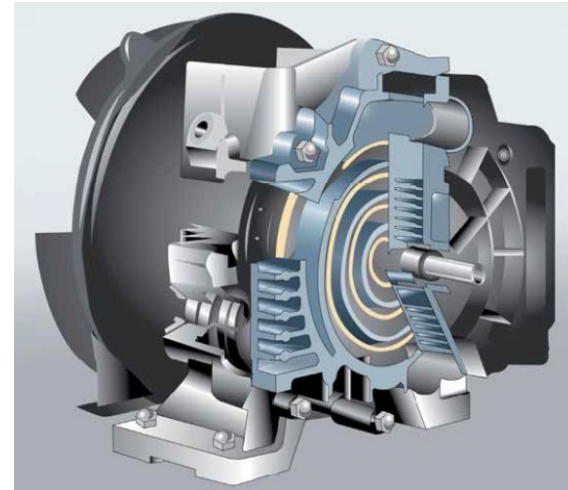
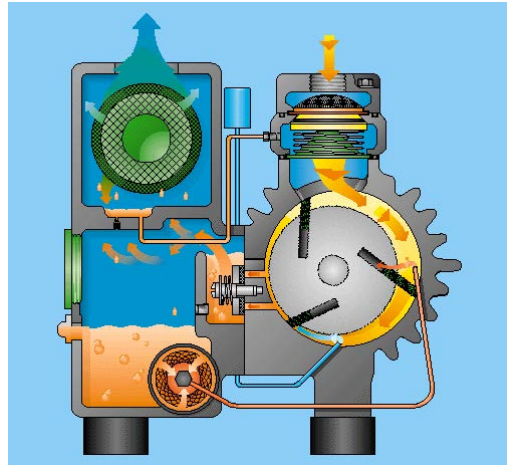
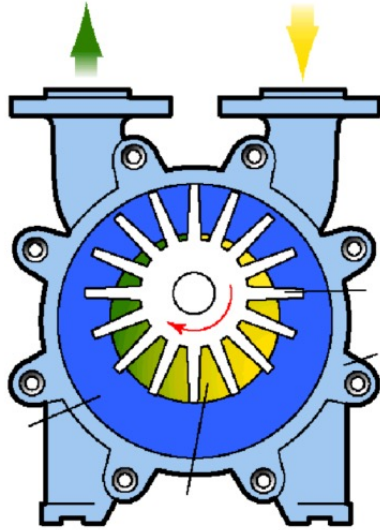

# Reciprocation Compressors

- Reciprocating compressors can be either single acting or double acting.

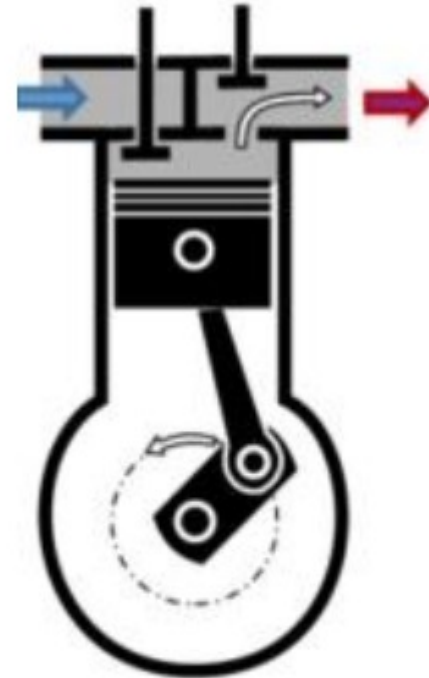

Single  
action

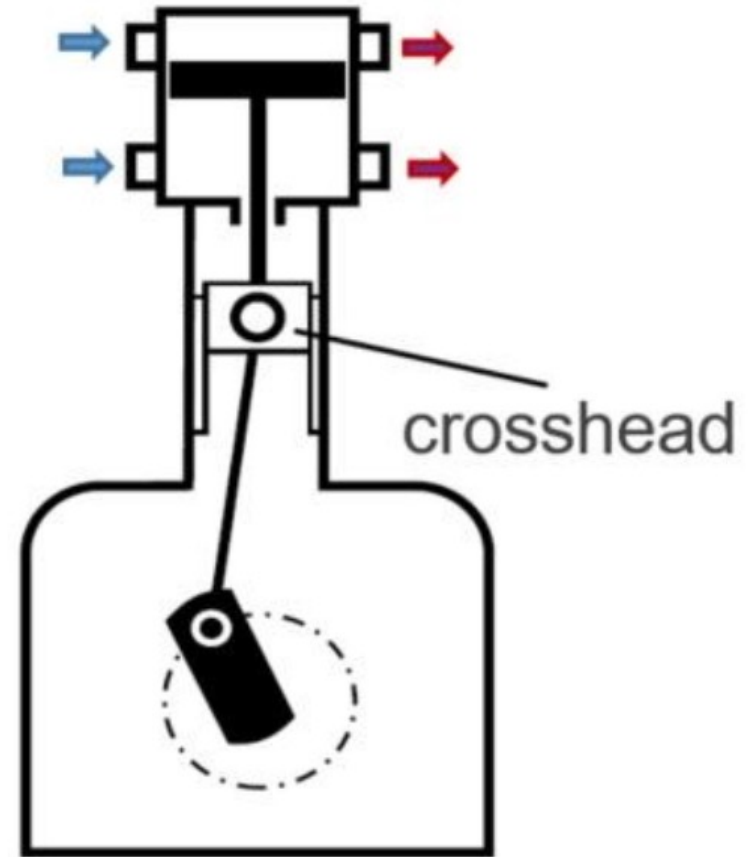

double action

# Reciprocation Compressors

- Single-stage compressors compress air once from the inlet pressure to final discharge pressure.
- Multi-stage compressors compress air to one pressure, then compress it to a higher pressure in another stage or stages.



Single-Stage



Two-Stage



# Reciprocation Compressors

- Compressors can be single-stage or multistage units.

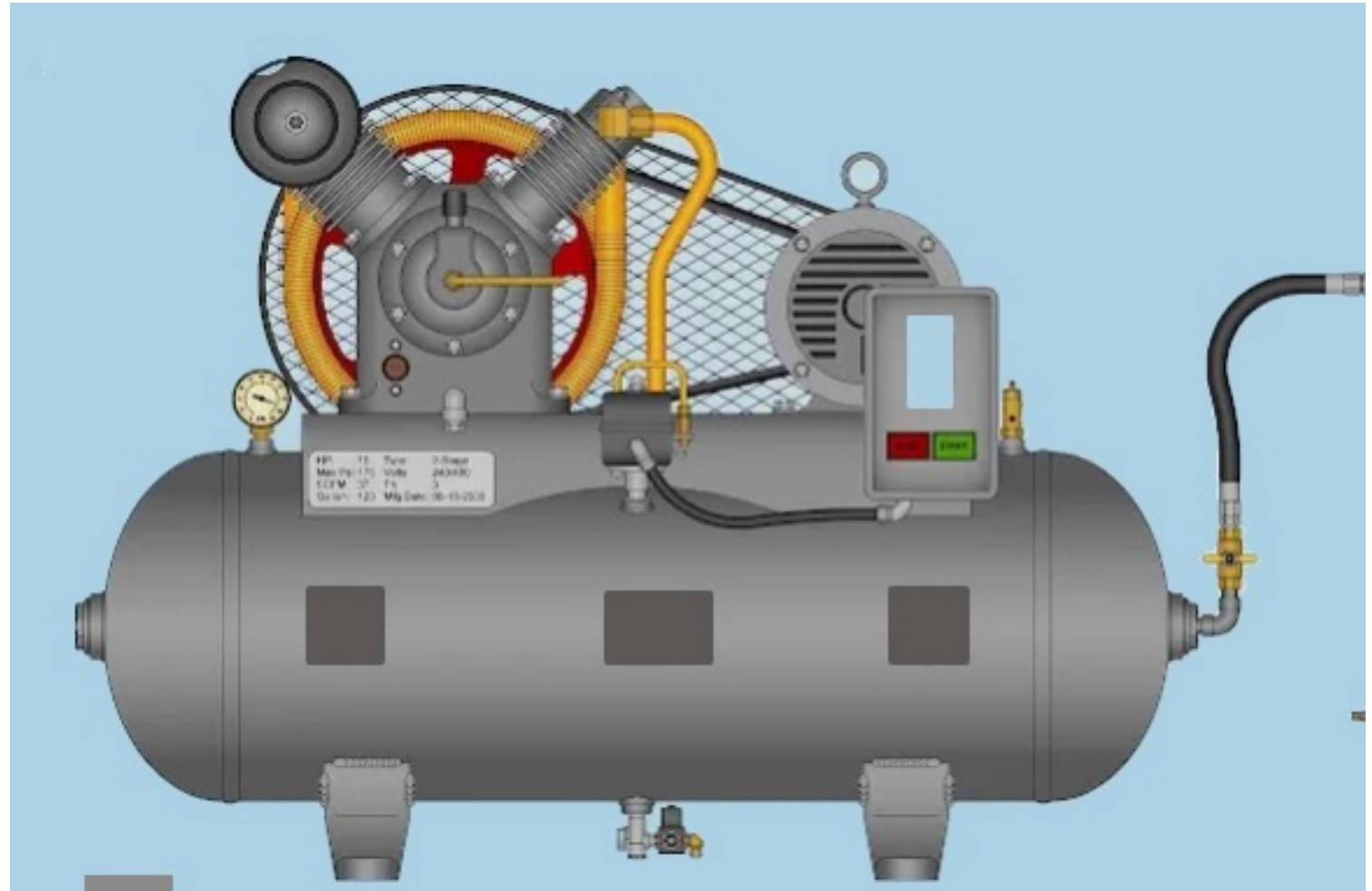

# Reciprocation Compressors

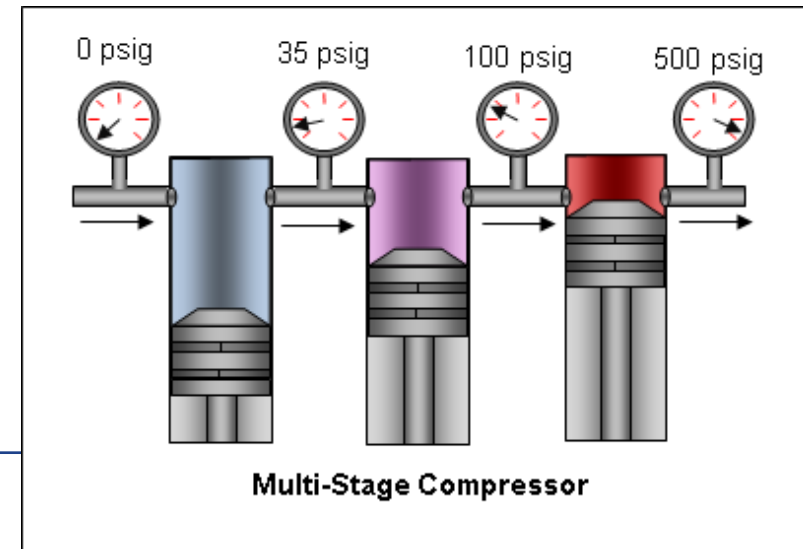
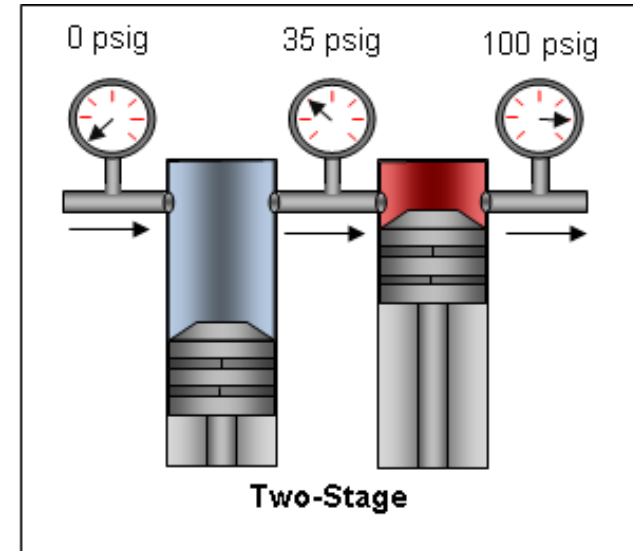
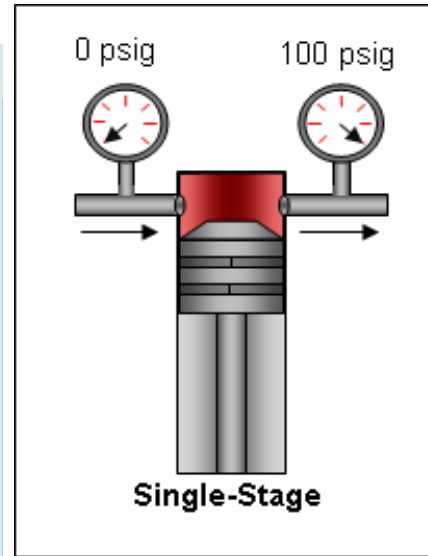
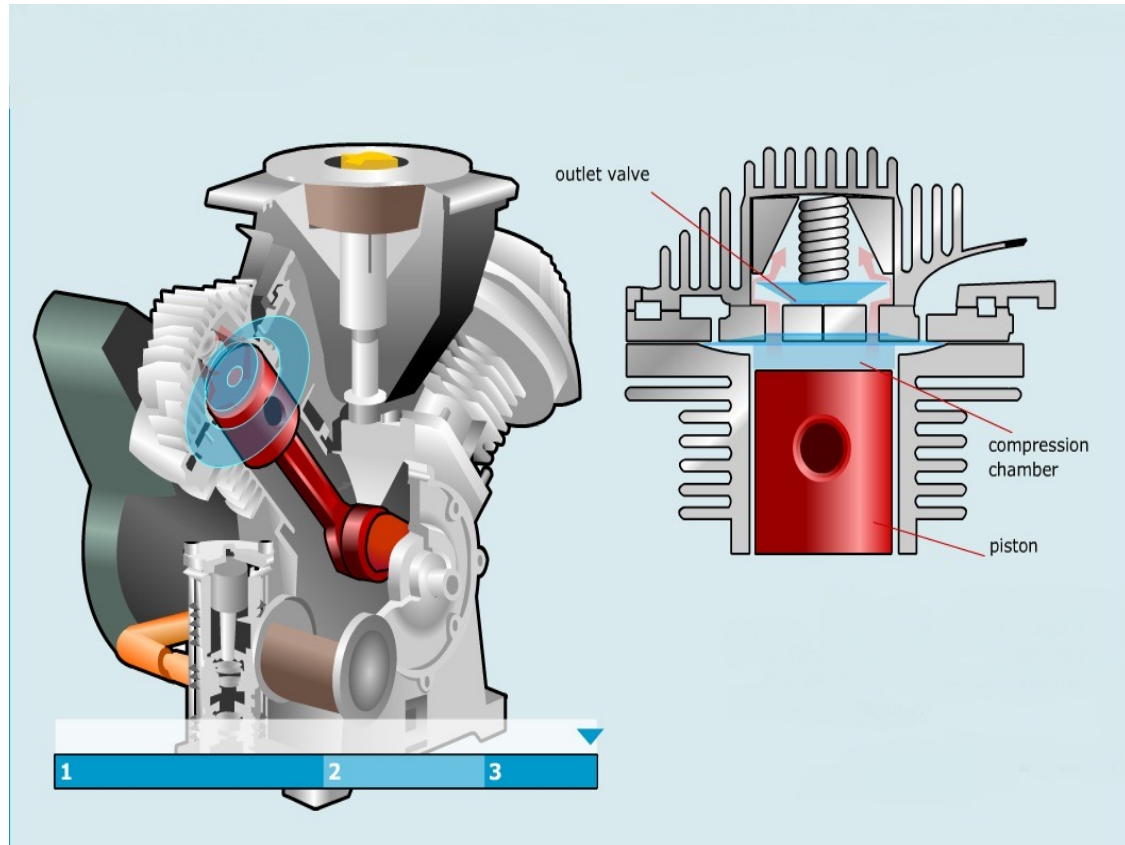

# Single Vs Two Stage

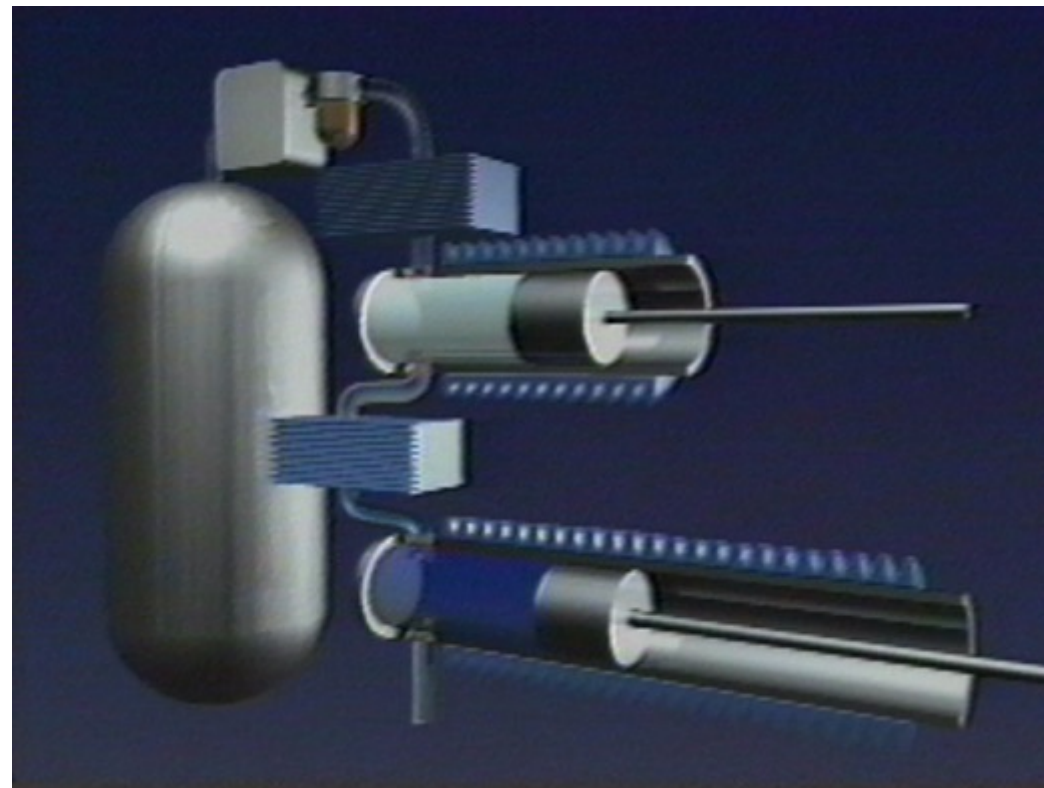
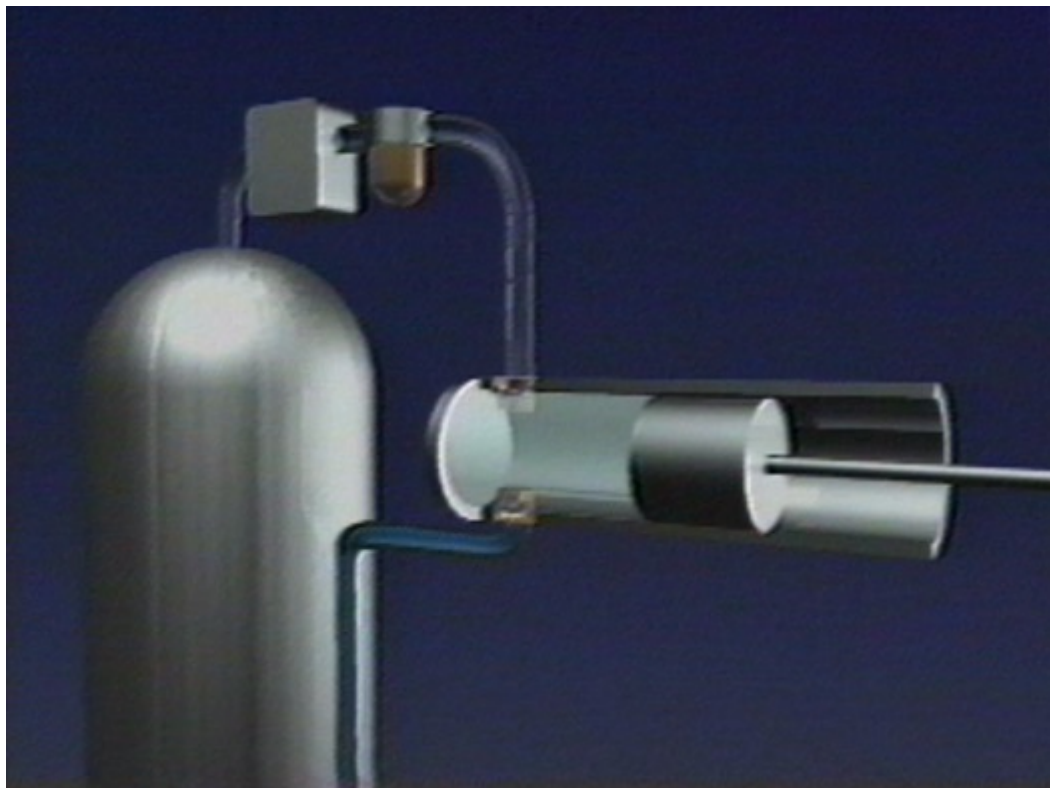

# Double Acting

- Cooling water jackets normally are incorporated in the cylinders and cylinder heads to remove some of the heat of compression, maintain thermal stability and improve lubrication, reducing carbonization of valve parts.
- Water cooling jackets around valves and piston rod packing are essential due to localized heating.
- Valves may be located in the cylinders or in the cylinder heads.

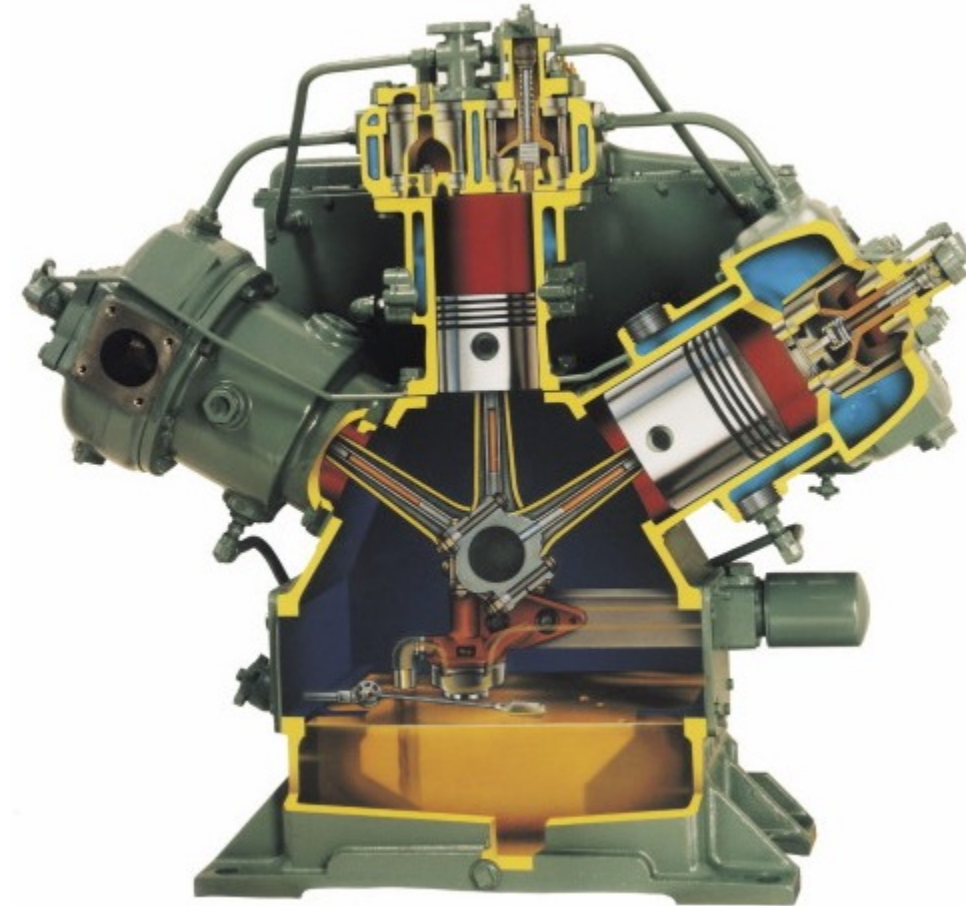

# Three Step

## Three-step free-air unloading

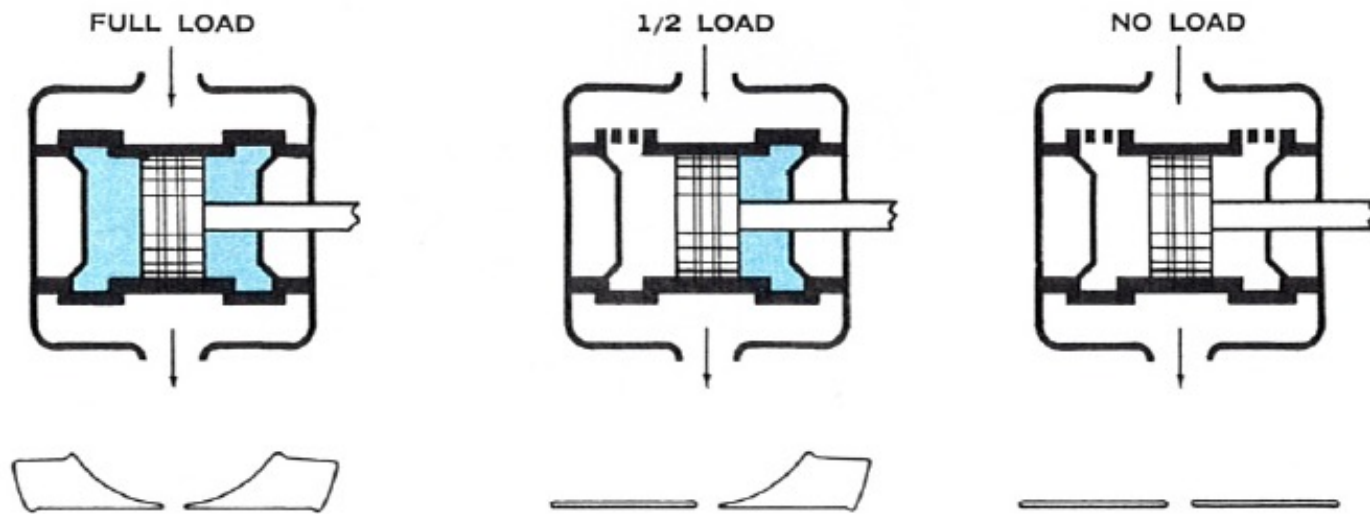

On 7" stroke sizes, Free-Air Unloaders hold the inlet valves open to unload the cylinders, both for reducing the capacity of the compressor and to provide easy starting. All inlet valves are equipped with unloaders to provide free and full

passage area, thereby reducing unloaded horsepower. For one-half load, one end of each cylinder is unloaded; for no load both ends are unloaded. The unloaders are air-controlled by the 3-step regulator.

# Five Step Using Clearance Control

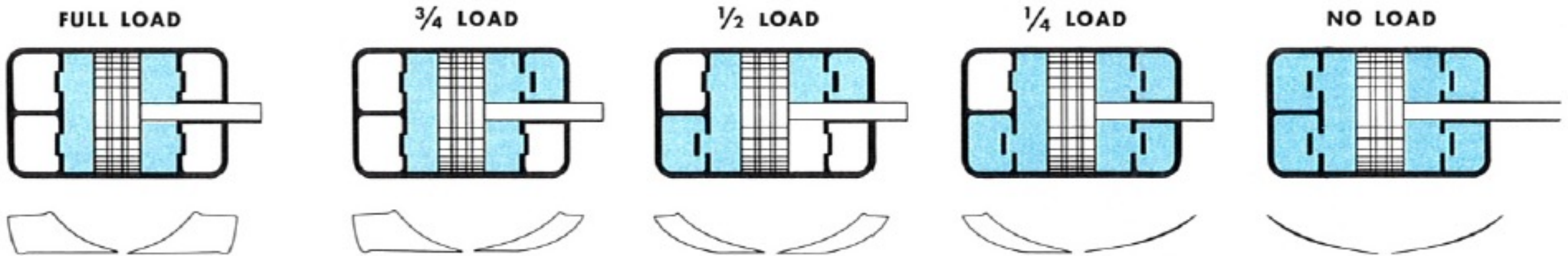

- The principle of 5-Step Clearance Control Regulation is to increase the cylinder clearance by definite and equal steps as shown by the diagram, thus reducing the cylinder capacity whenever the demand falls off.
- When one clearance valve is open, the volume of that pocket is added to the normal cylinder clearance volume.
- This cuts in half the amount of air taken into that end of the cylinder.
- The sizes of the pockets are proportioned so that when both pockets at one end are opened, no air is taken into that end of the cylinder when operating at rated pressure.

# Water-cooled, 900 HP Two Stage, Double Acting, Recip



# Two Stage, Double Acting, Recip





# Double-Acting Reciprocating Compressors

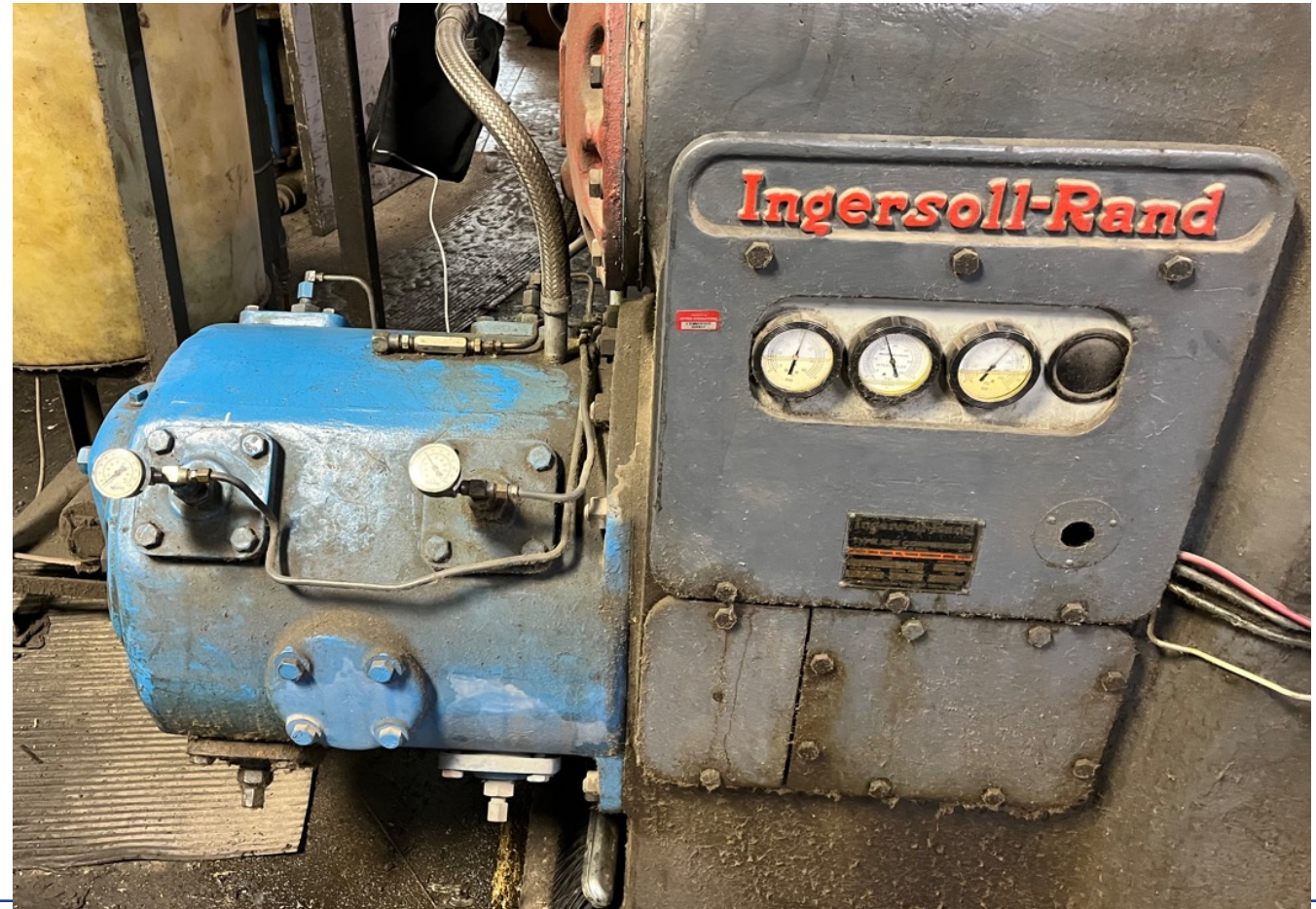

# Double-Acting Reciprocating Compressors



# Oil Free Reciprocating

- Oil-free or oil-less reciprocating compressors do not have any lubricant fed to the cylinder or cylinders.
- Piston rings and rod packing usually are of PTFE based materials, carbon, or other synthetic materials, which can operate without added lubrication.



# Oil-Less

- Oil-less compressors have no oil in the compression chamber or in the crank case. They can be Reciprocating or Rotary.

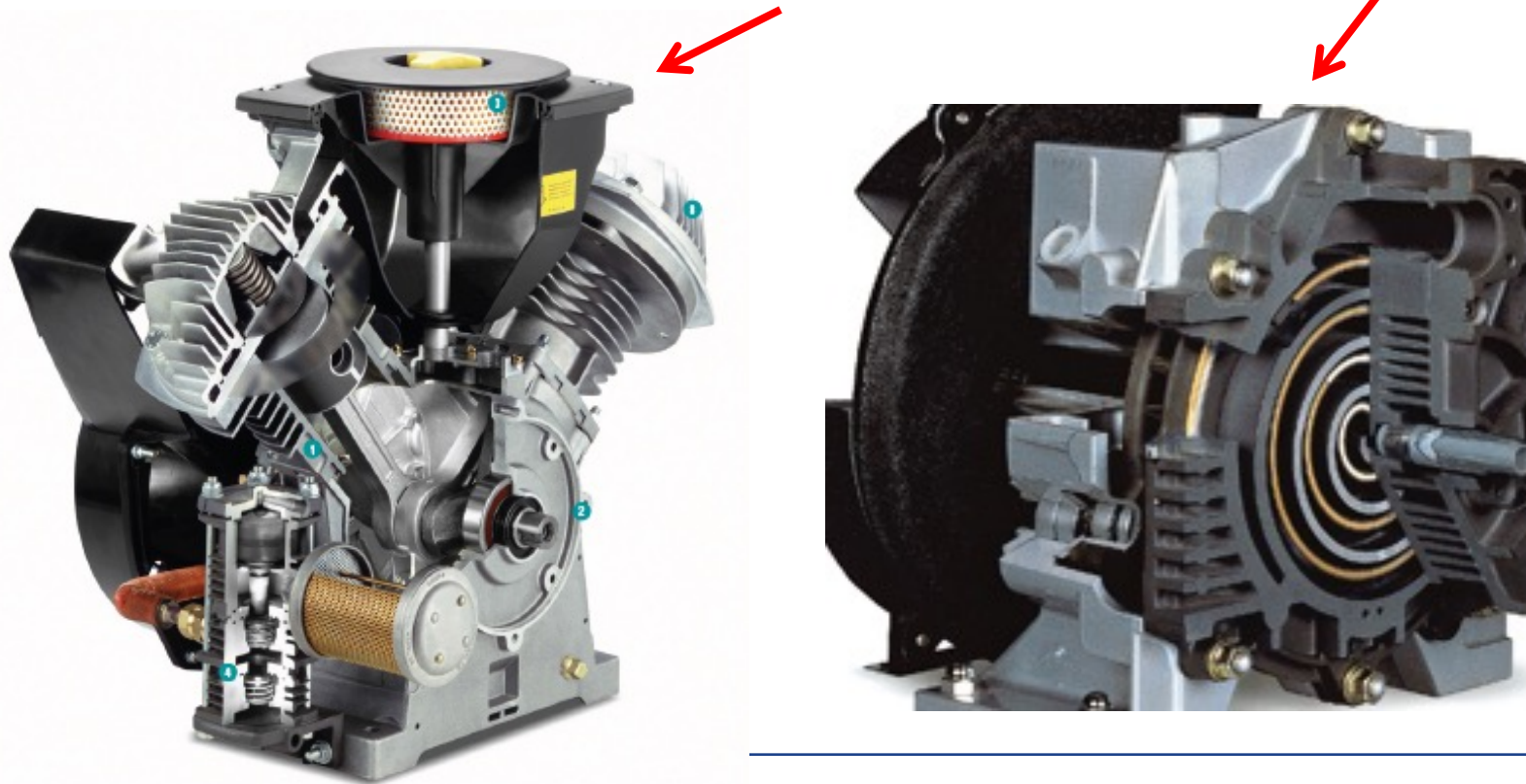

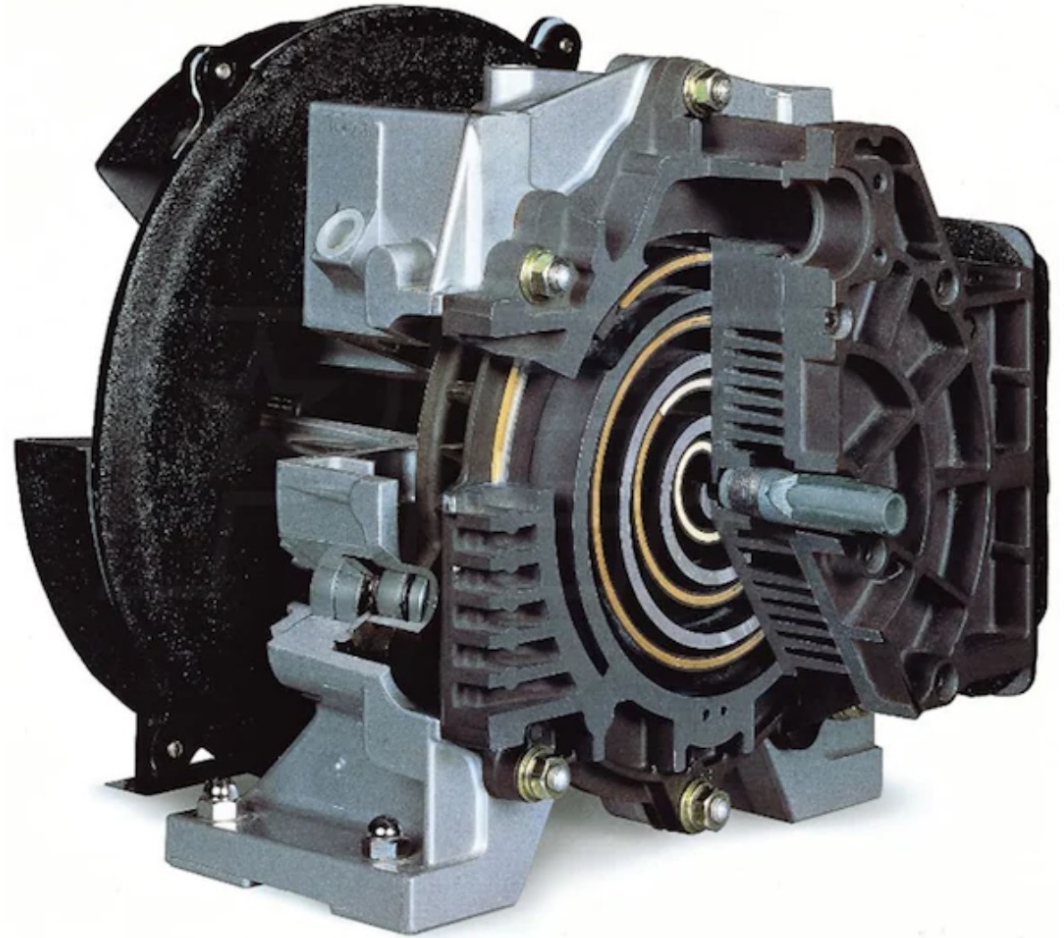
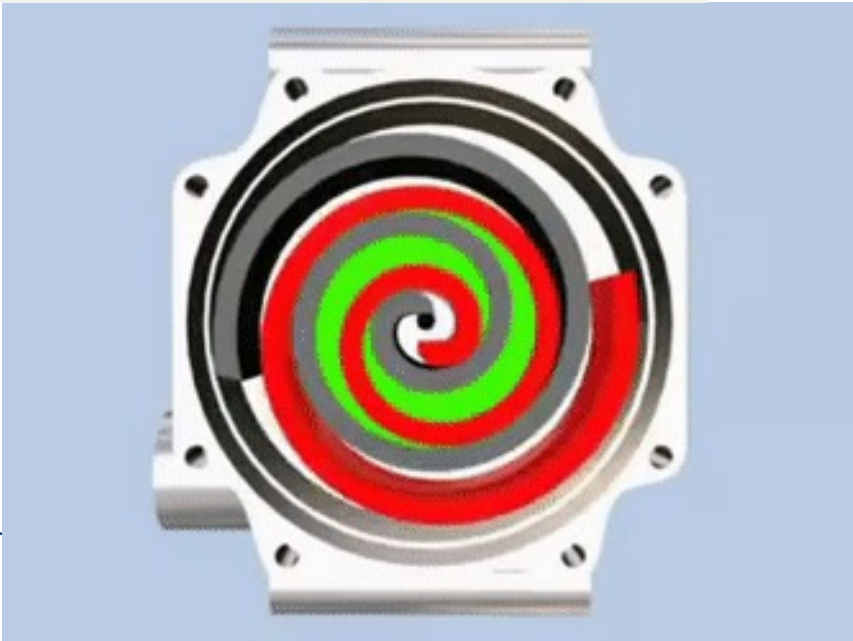
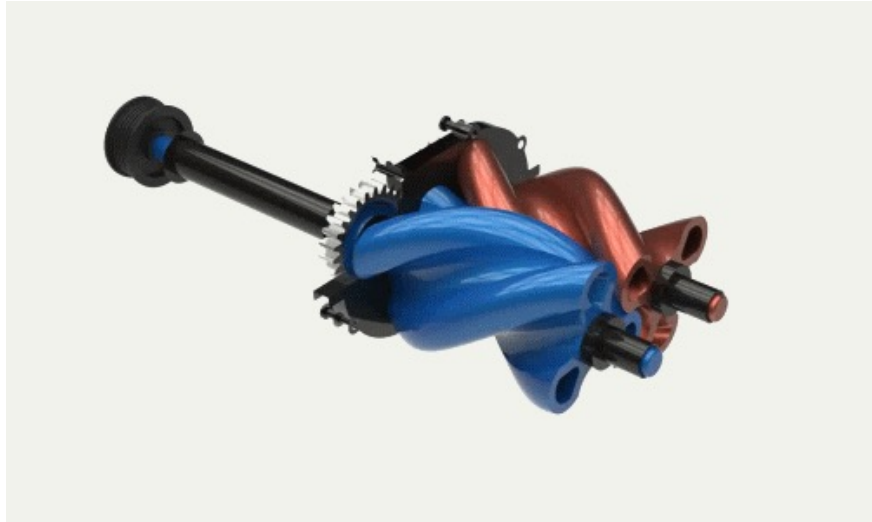

# Rotary Screw

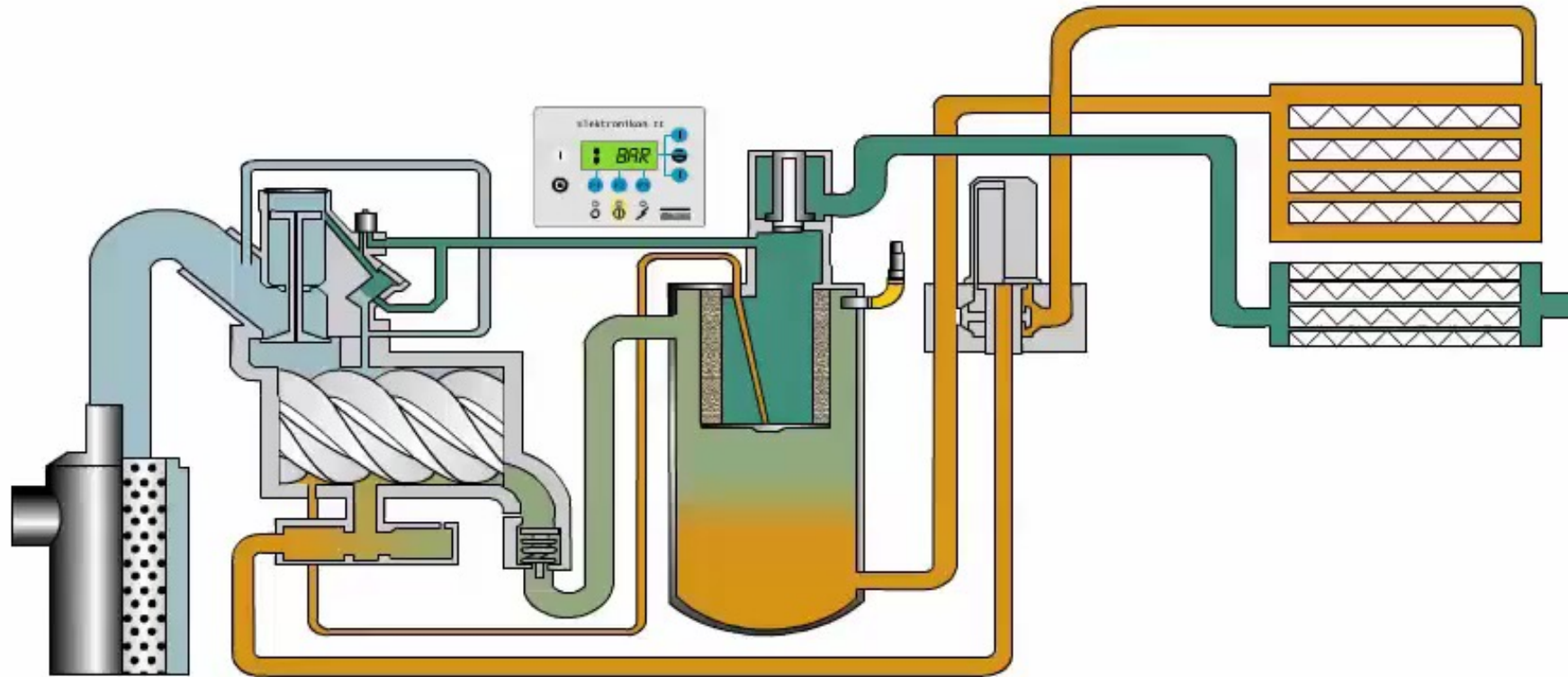

# Gear Drive Rotary Screw Air End

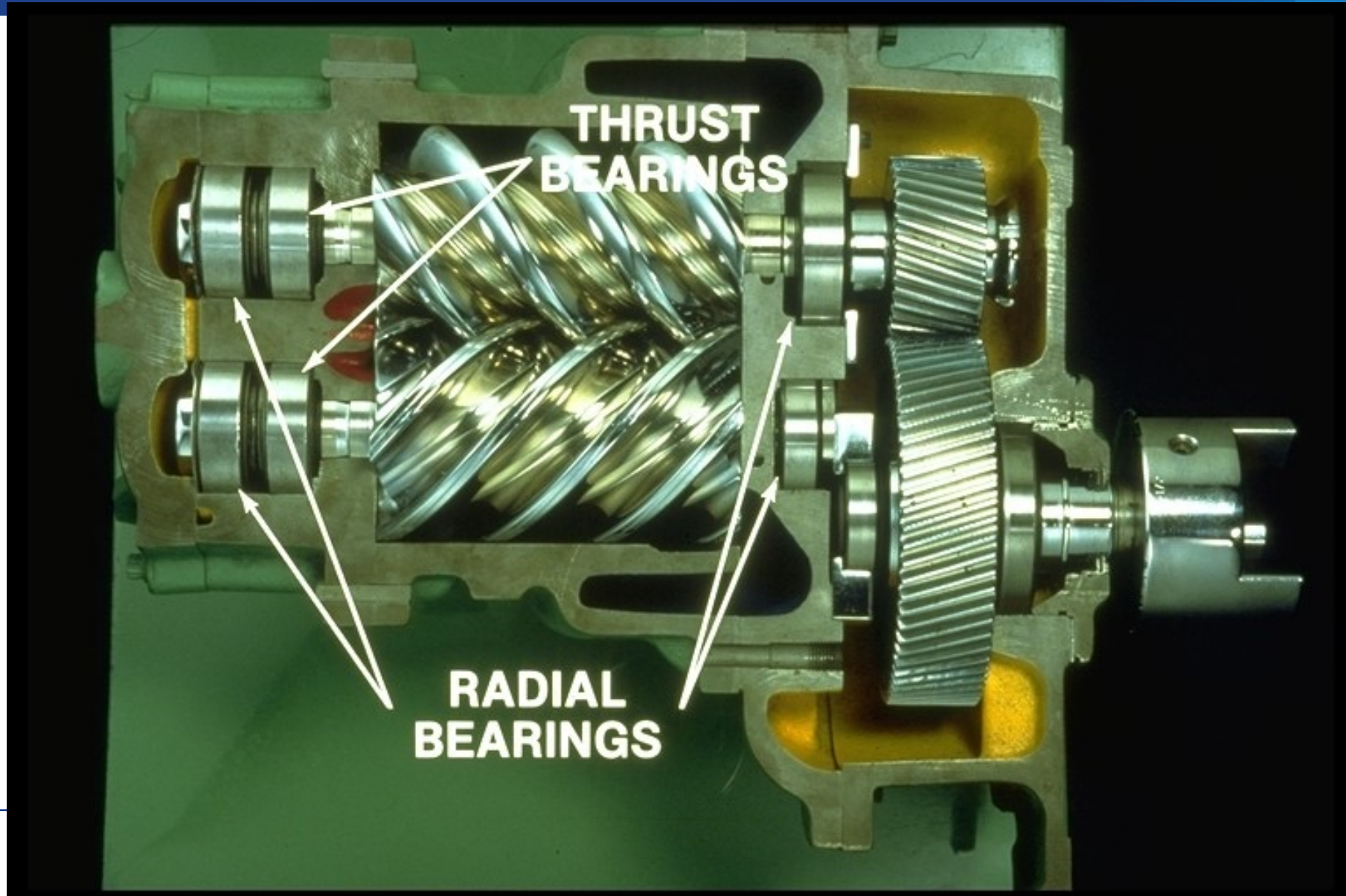

# Direct Drive Rotary Screw Air End

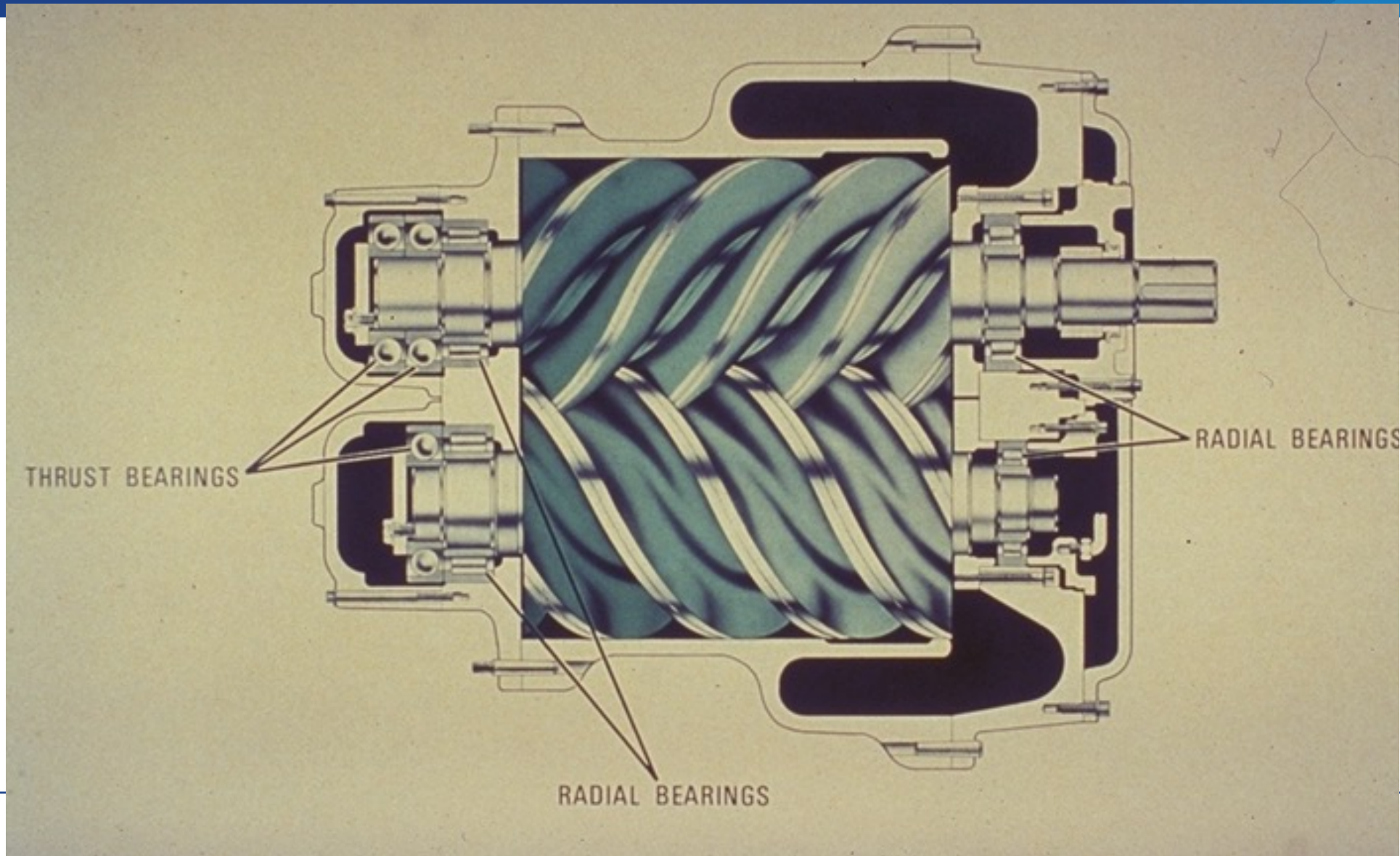



# Rotary Screw

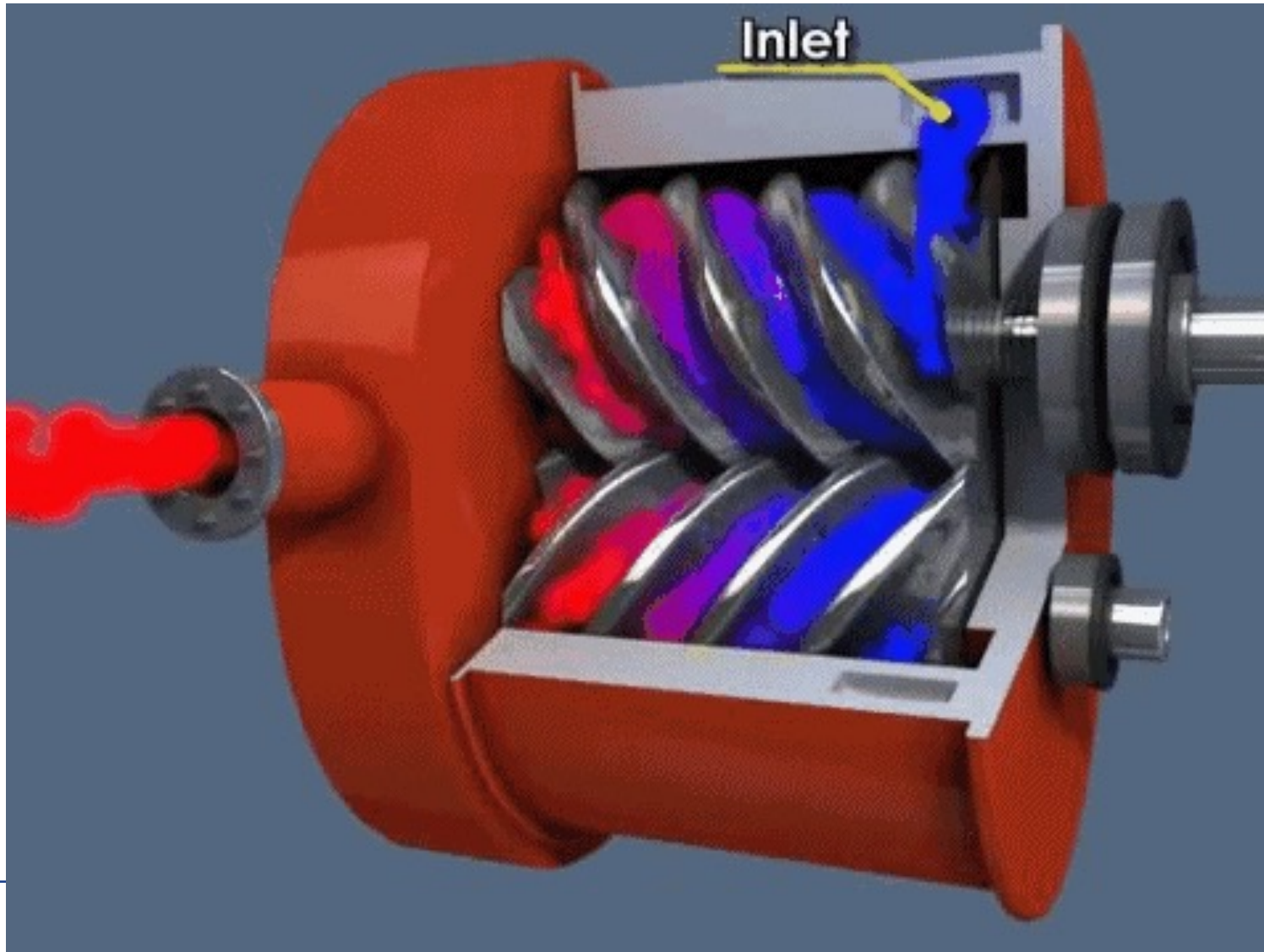

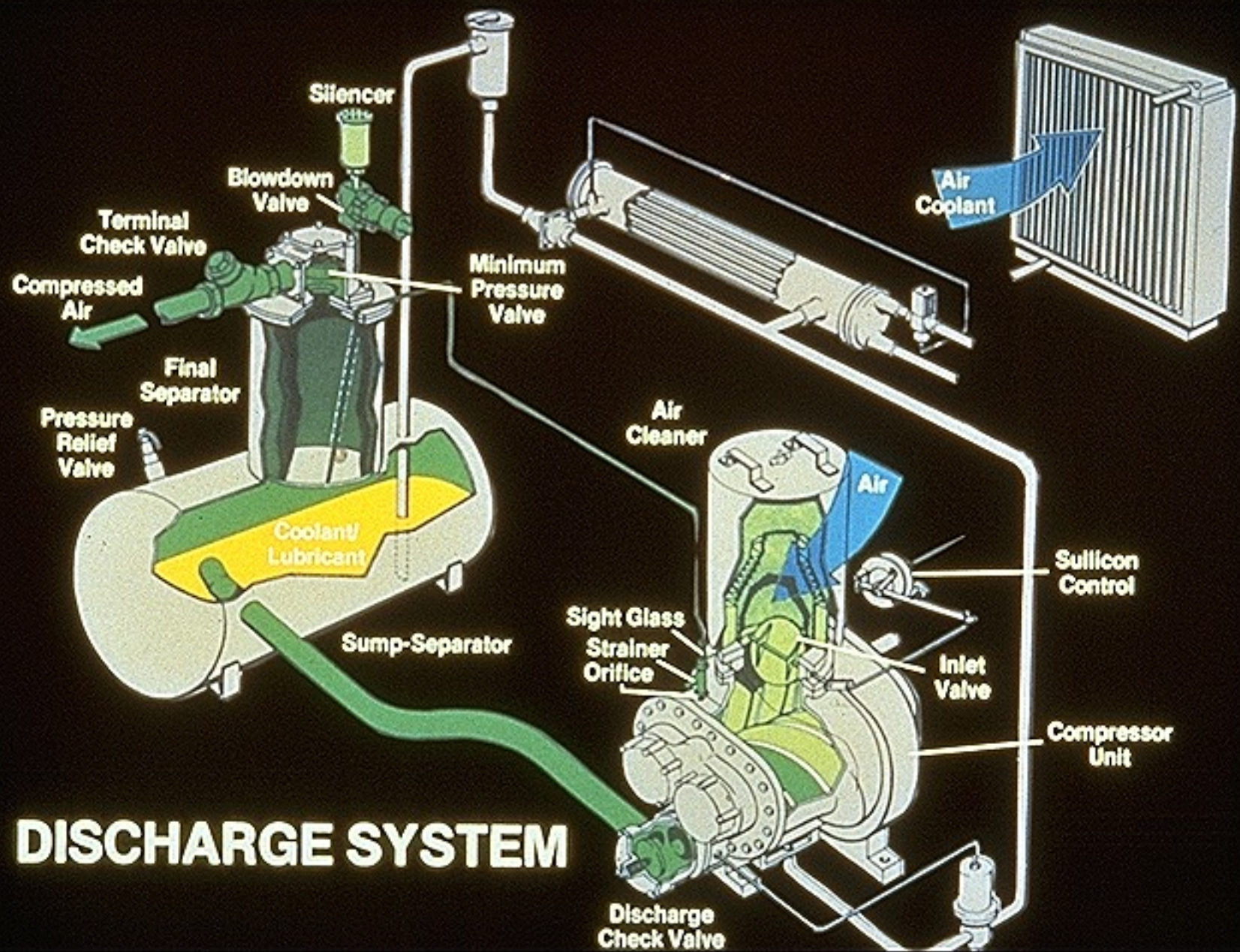

# DISCHARGE SYSTEM

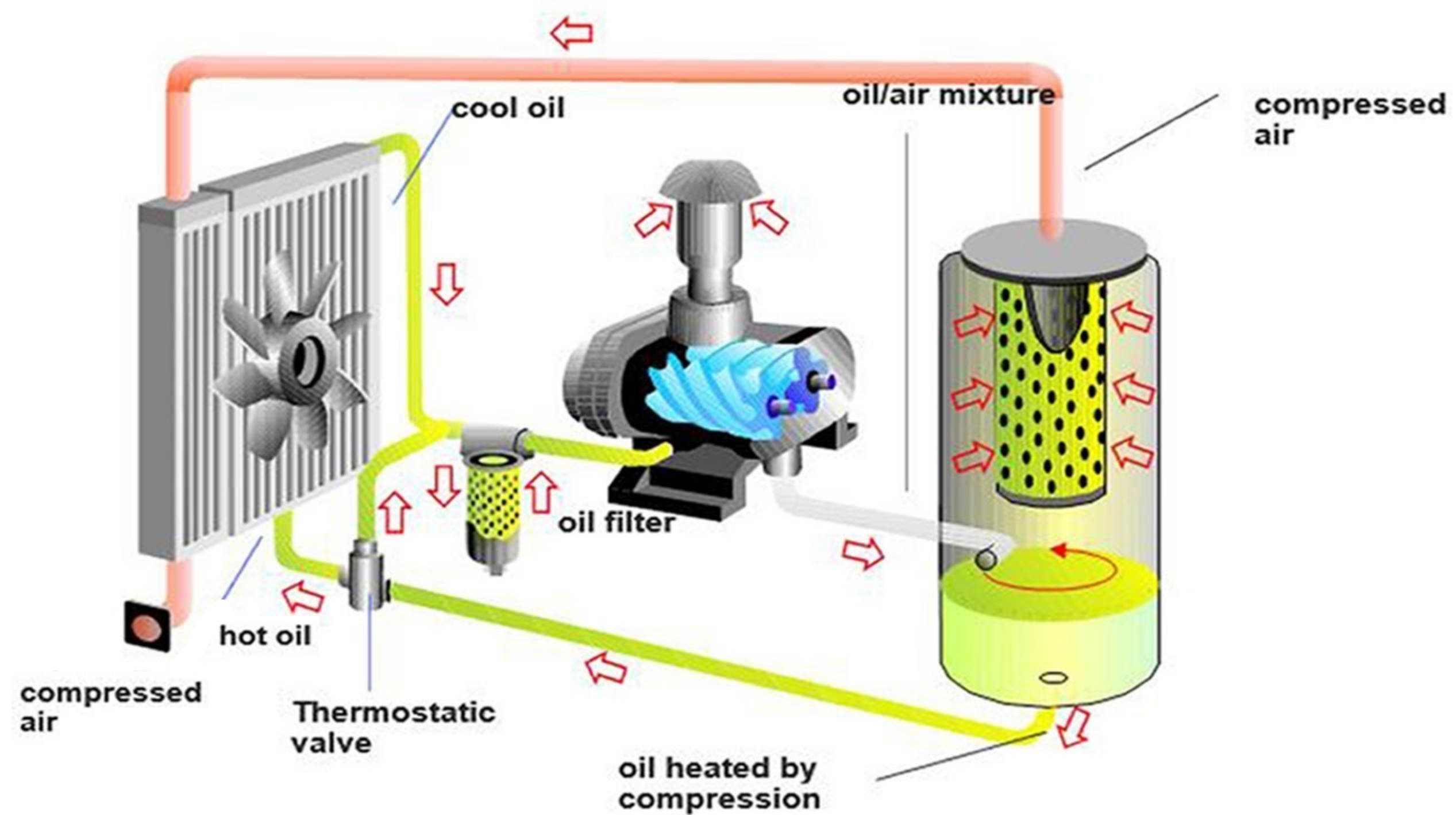

# AIR LEAKAGE

Female Rotor

Male Rotor

Stator

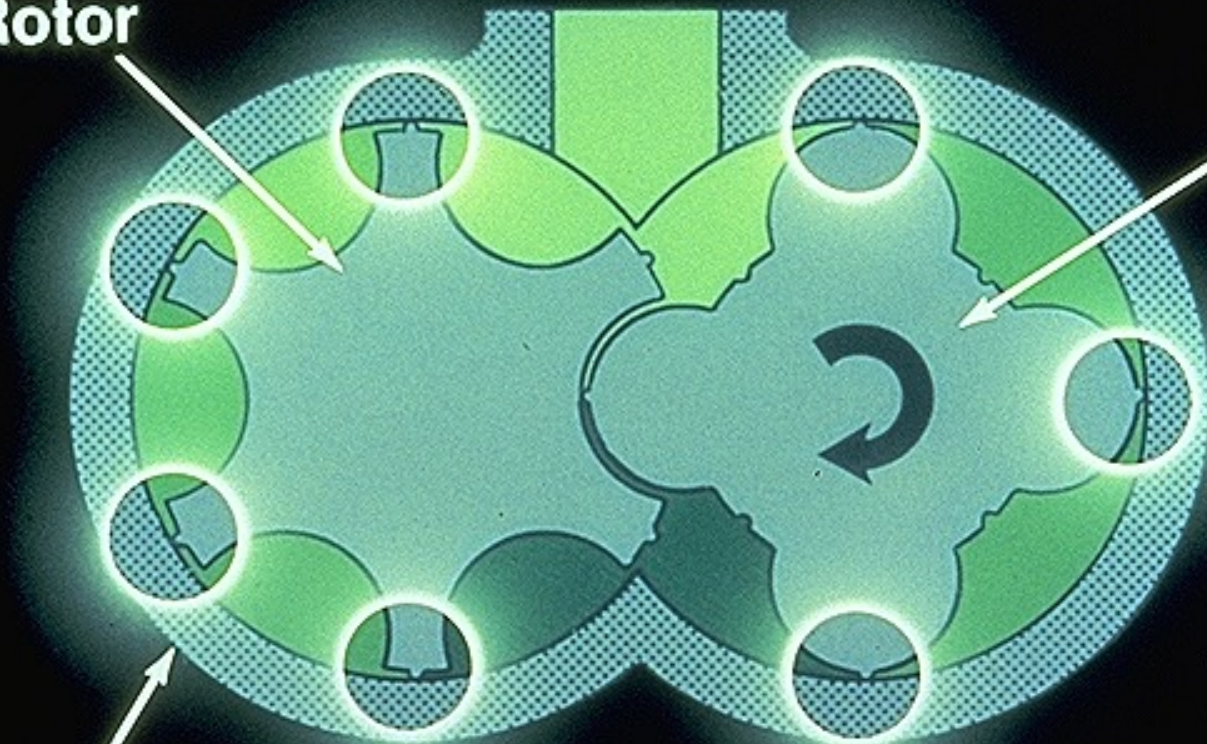

# Rotary Screw Compression

- Rotary Screw compression process--traps consecutive quantities of gas between the male lobe and female flute.
- As screw turns, the enclosed volume decreases, thus increasing the pressure.
- Compressed air is then pushed out of the element at the discharge port.

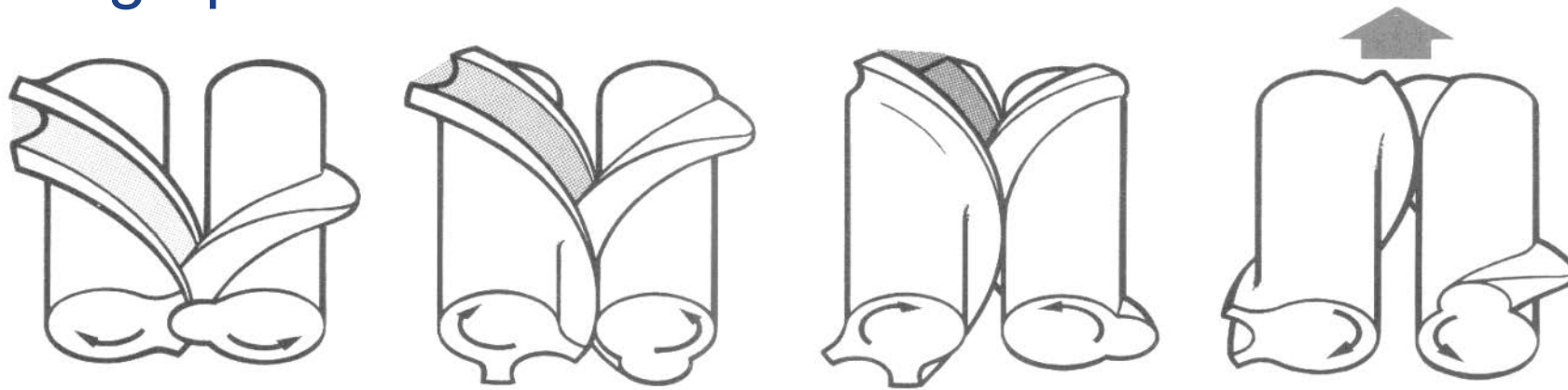

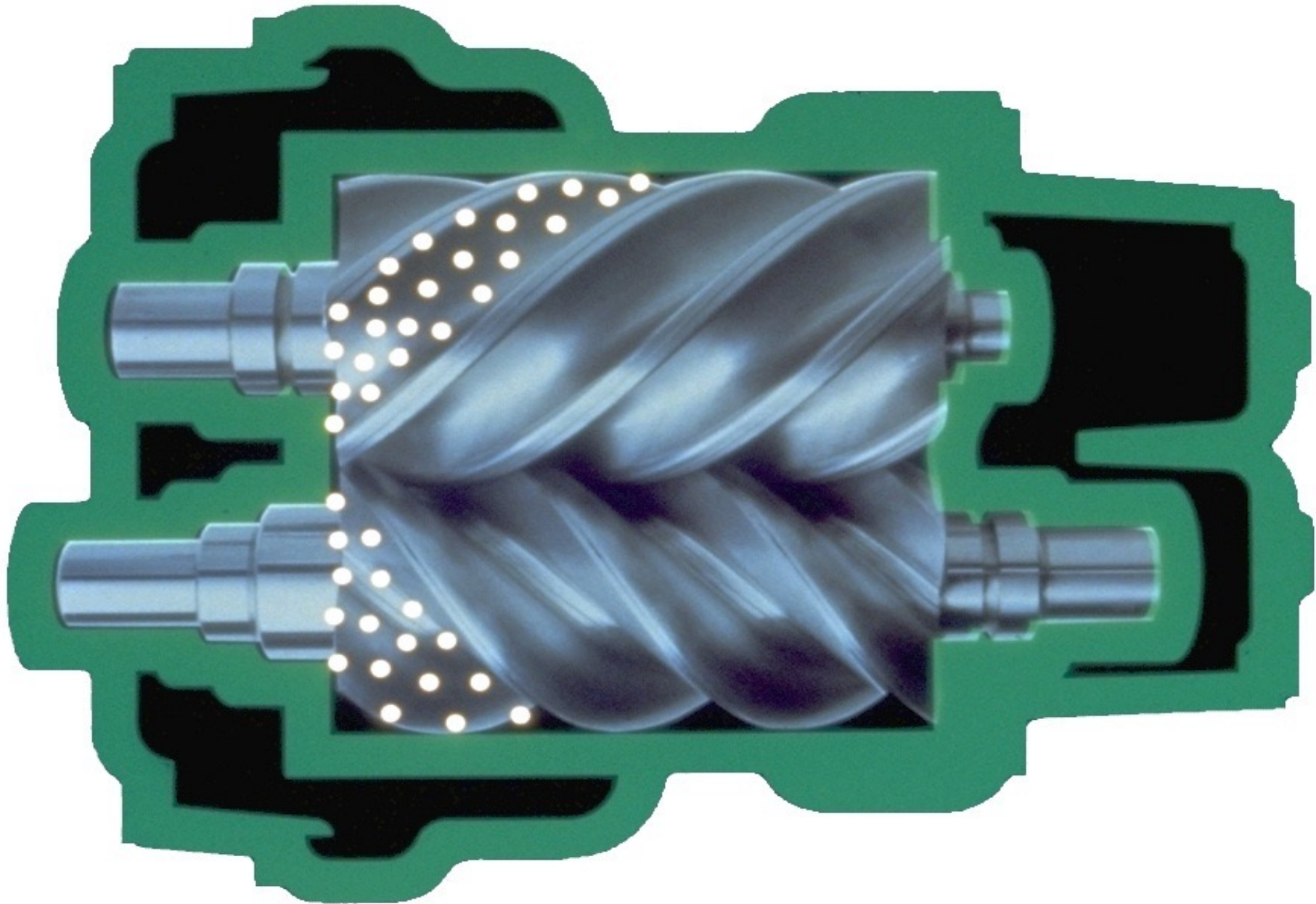

Low pressure gas is drawn axially into the unit as the rotors turn past the intake port in the housing

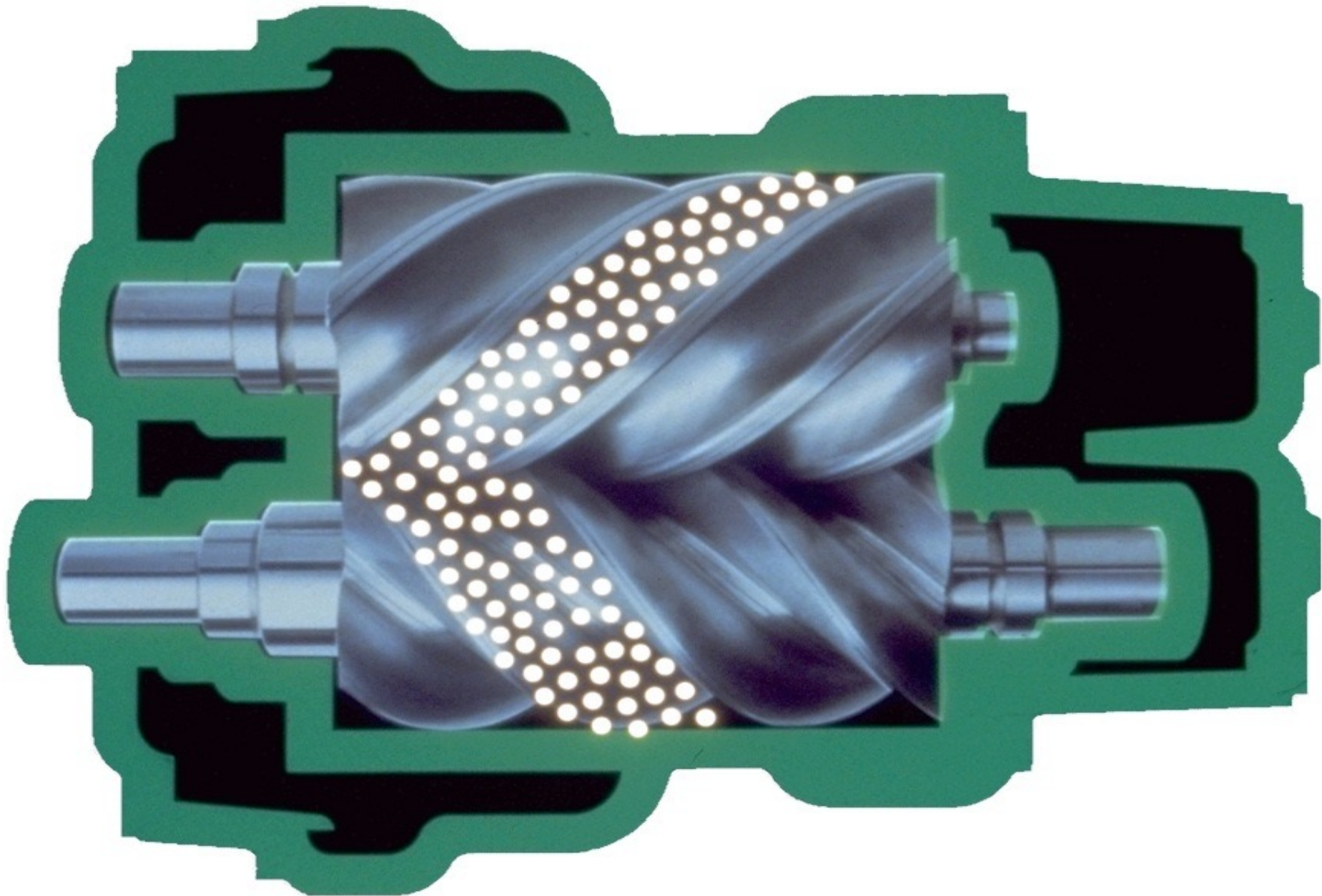

The rotors have turned past the intake port; gas is trapped in the unit housing and rotor cavities.

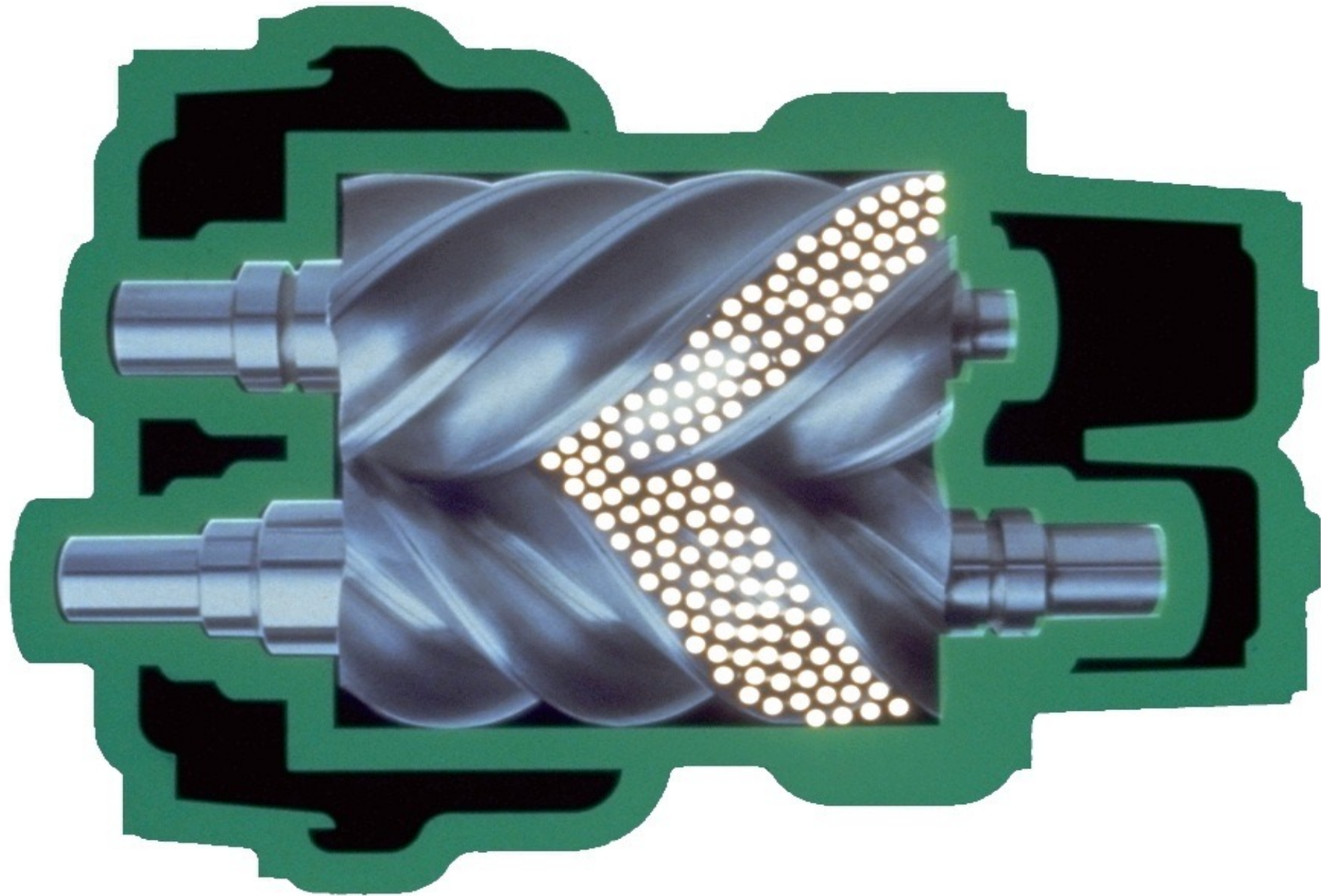

As the rotors continue to turn, lobes reduce the volume in the cavities, raising the pressure of the trapped gas.



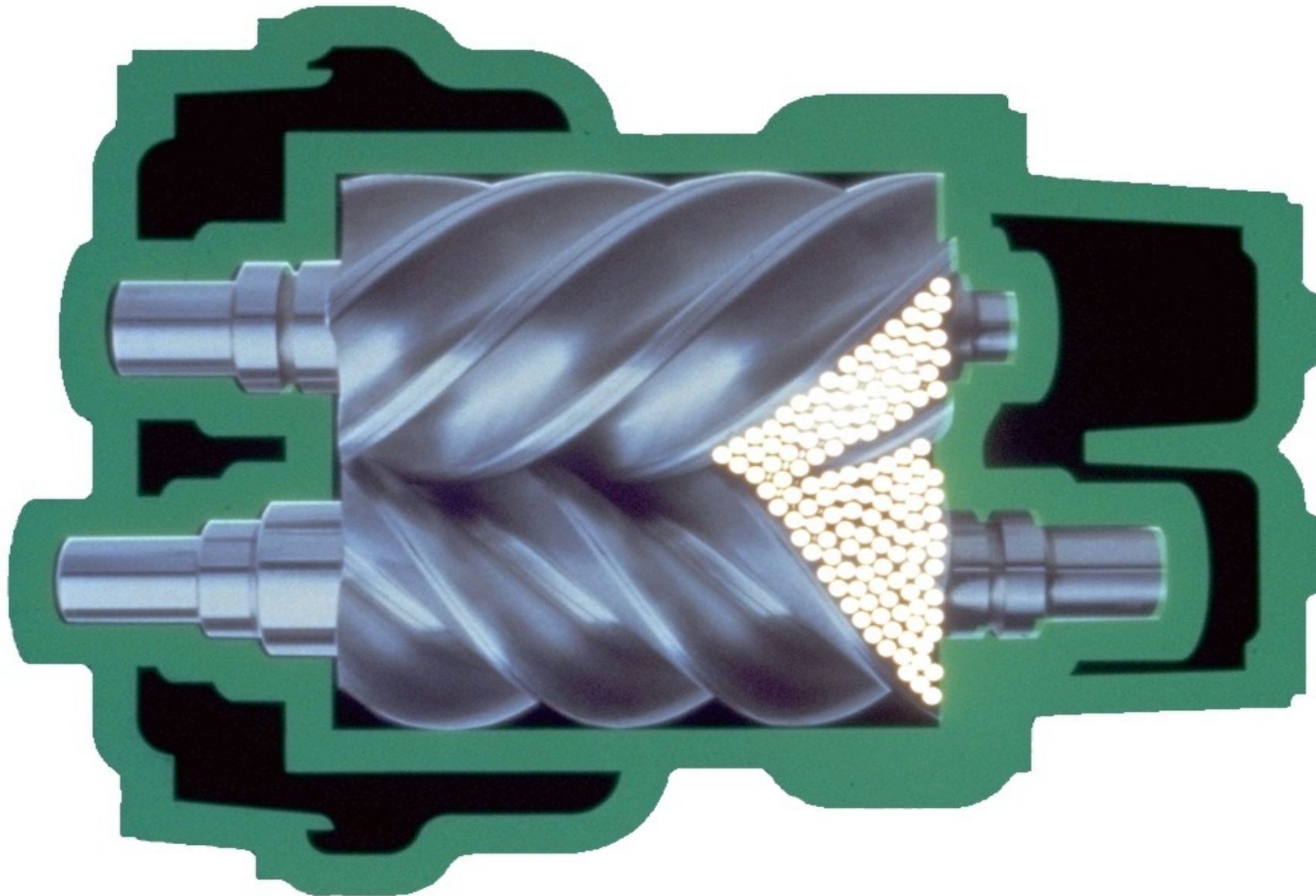

The cycle is completed as compressed gas is discharged through the outlet port at the bottom of the housing to atmosphere or to some positive pressure as may be required by the process

# Rotary Screw

- In an oil injected rotary screw compressor, the air and lubricant mix for cooling, sealing and lubrication, the lubricant is separated later, within the full compression cycle.

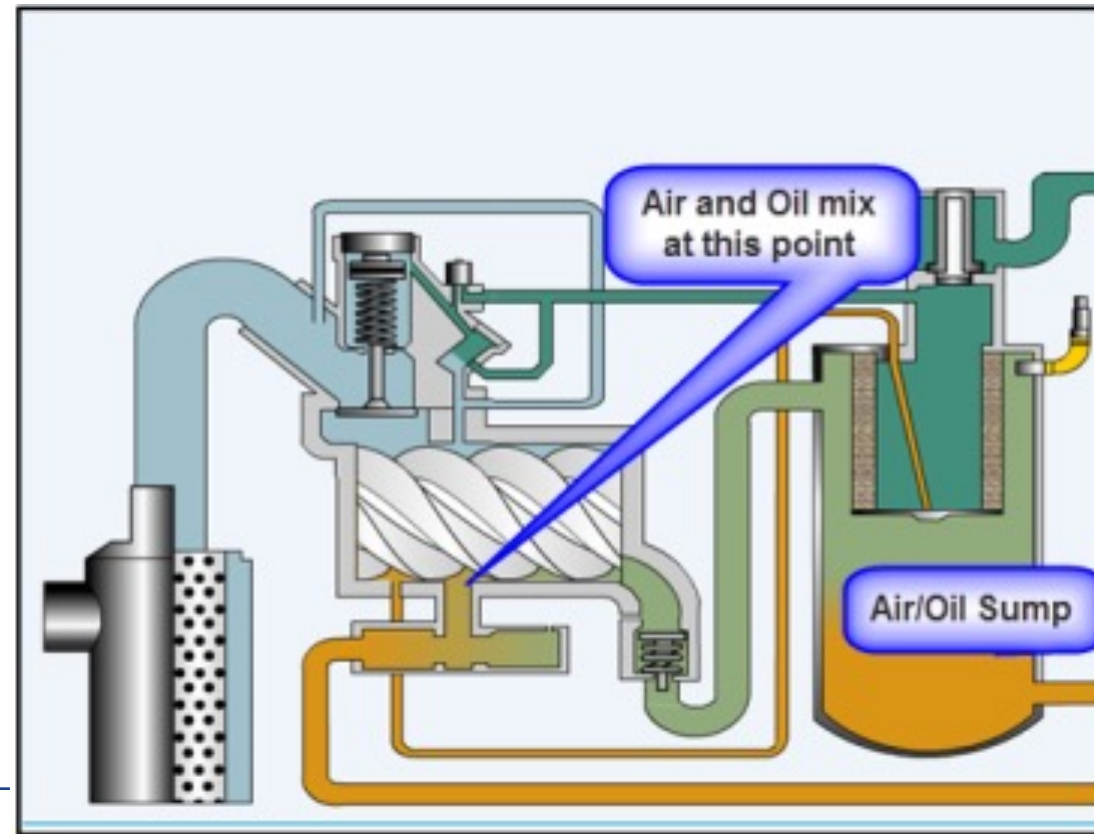

# Rotary Screw

- A minimum pressure valve assures proper lubricant circulation and separation. Once separated, it is returned to the air/oil reservoir.
- A lubricant thermal mixing valve is used to maintain a constant and correct injection temperature.

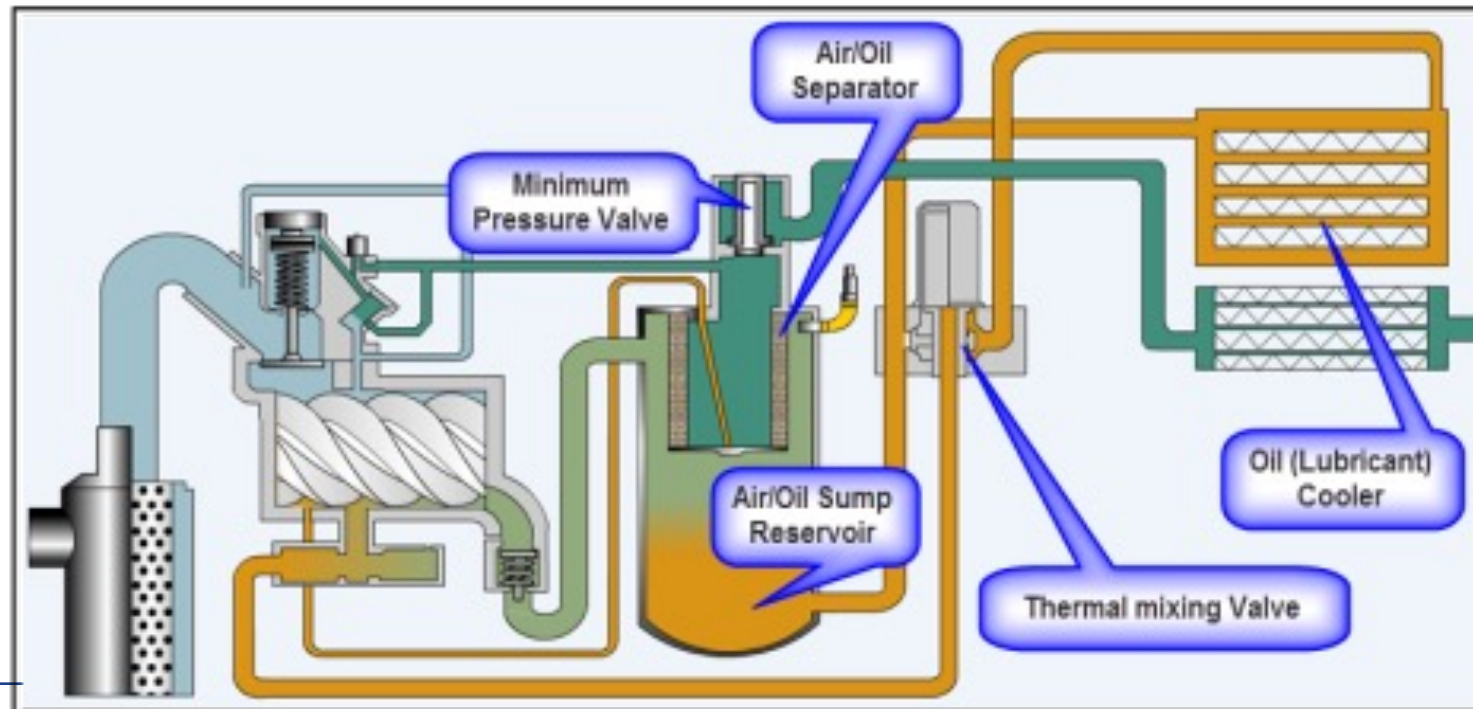

# Rotary Screw

- Suitable design temperature and viscosity of the lubricant are required for proper lubrication, sealing and cooling.
- Avoid excessive temperatures to avoid breakdown of lubricant.
- Important to keep lubricant clean.

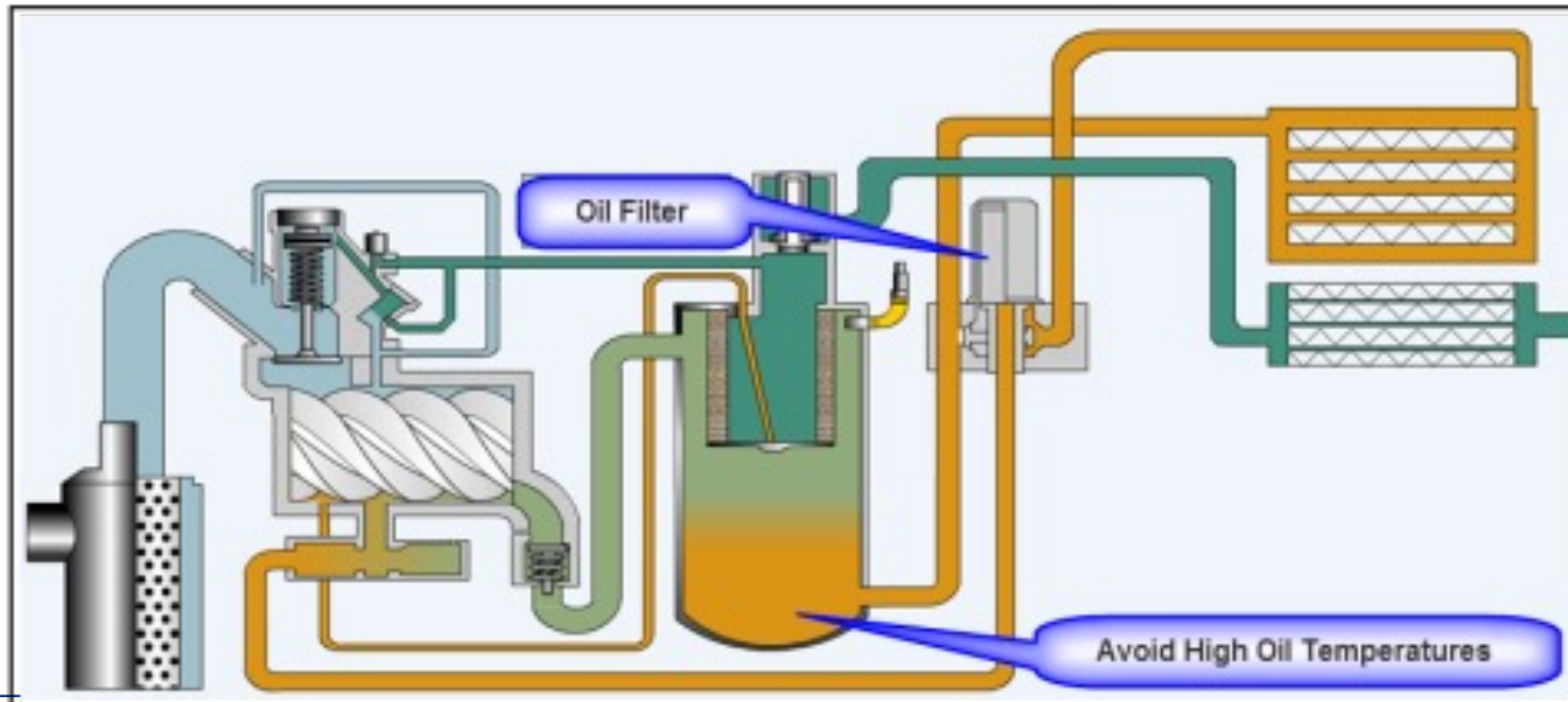

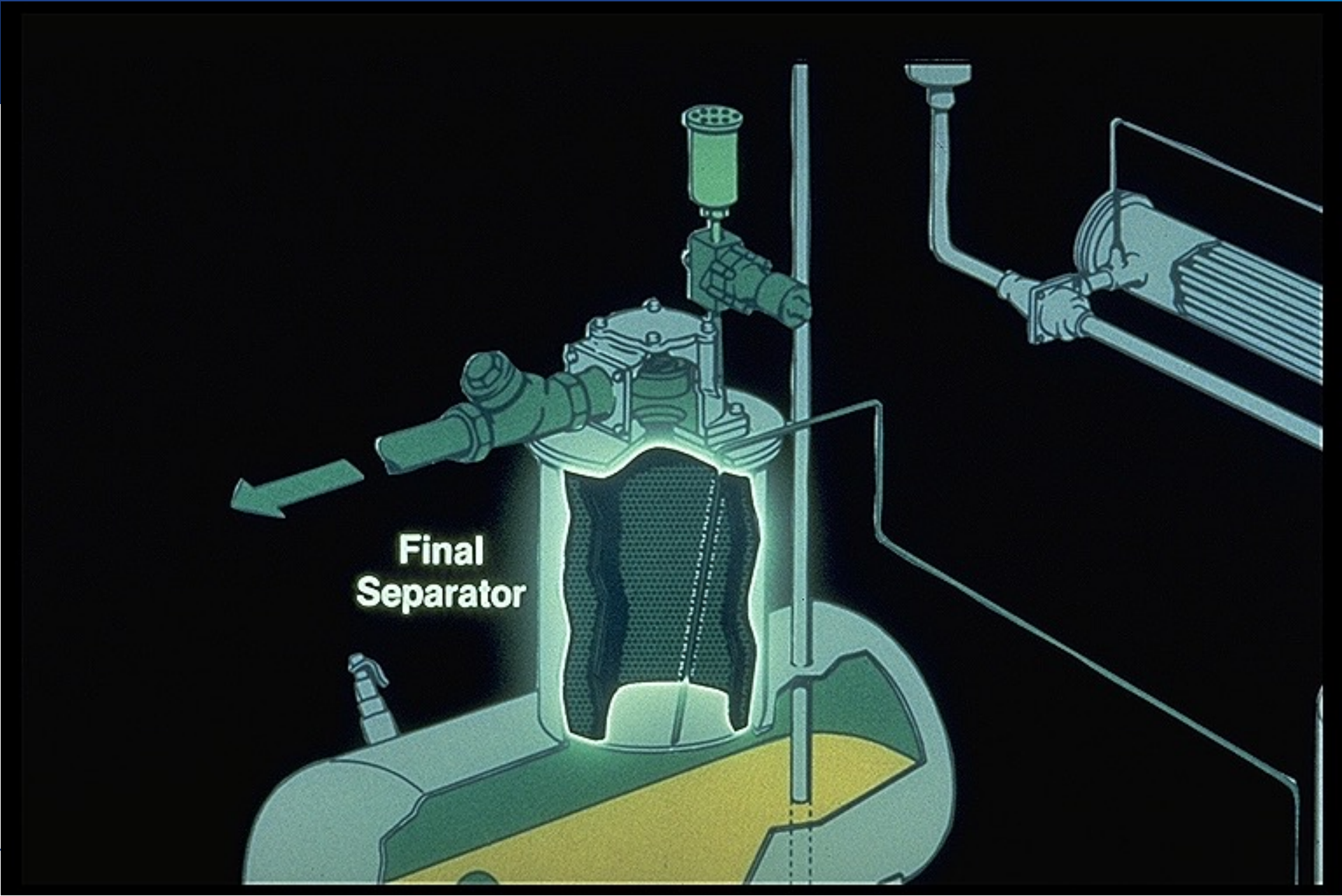

# SEPARATOR ELEMENT REPLACEMENT

SECONDARY  
ELEMENT

PRIMARY  
ELEMENT

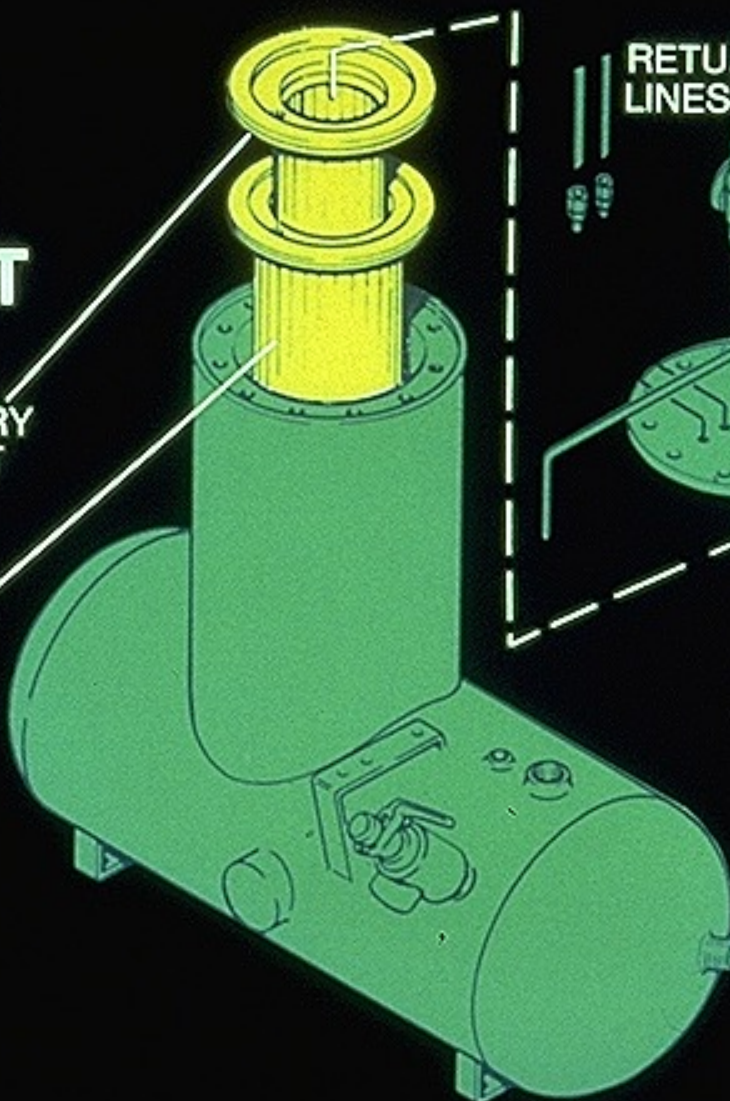

RETURN  
LINES

MPV/  
CHECK VALVE

CAPSCREW

LOCK  
WASHER

# THE VALUE OF A SEPARATOR ELEMENT

## OIL CARRYOVER OUNCES PER/HOURS CONVERSION

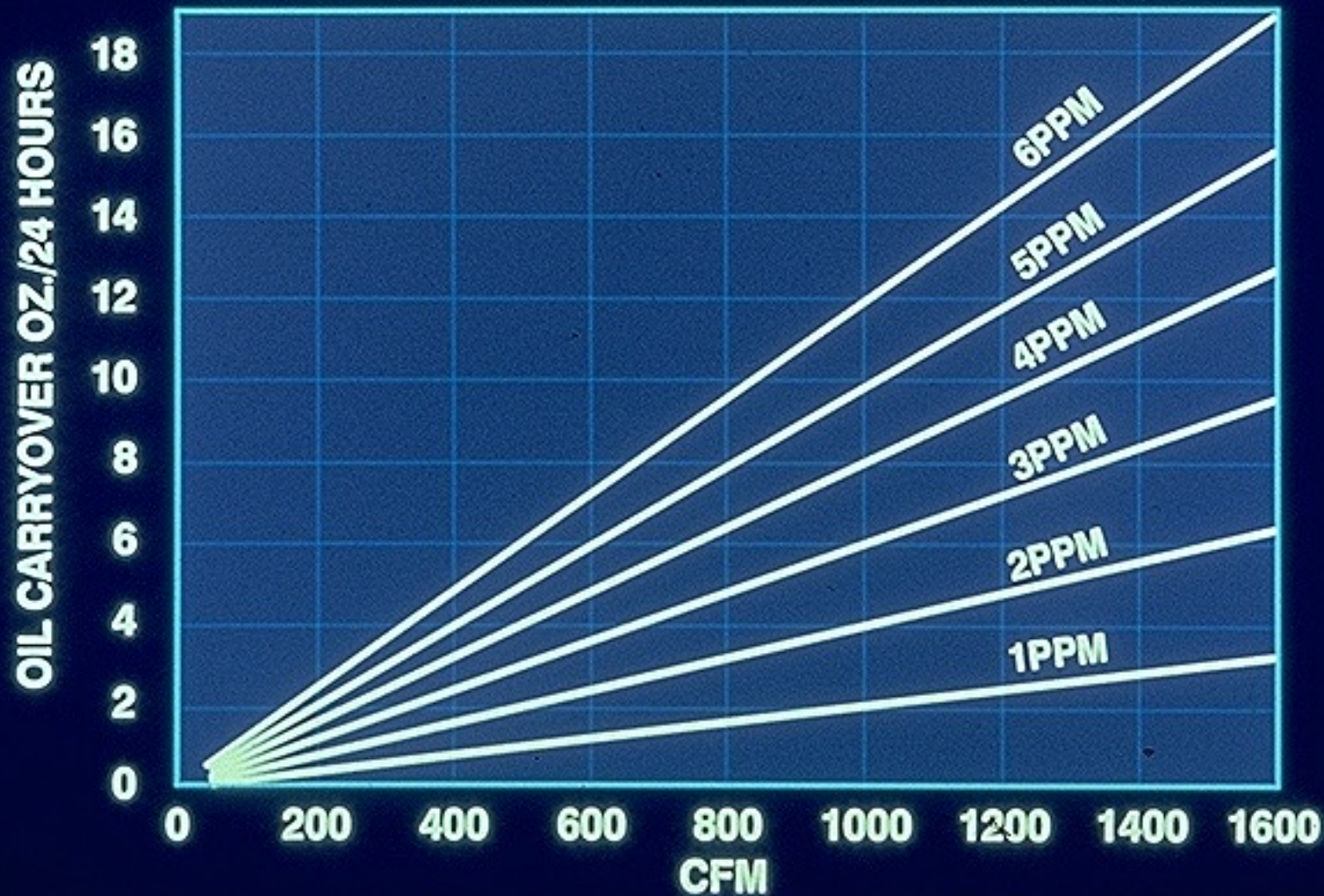

# Rotary Screw

- Lubricated rotary screw compressors are available in single stage, operating from 60-200 psig. As well as two stage compressors, which can operate as high as 290 psig.

Two Stage Compressor

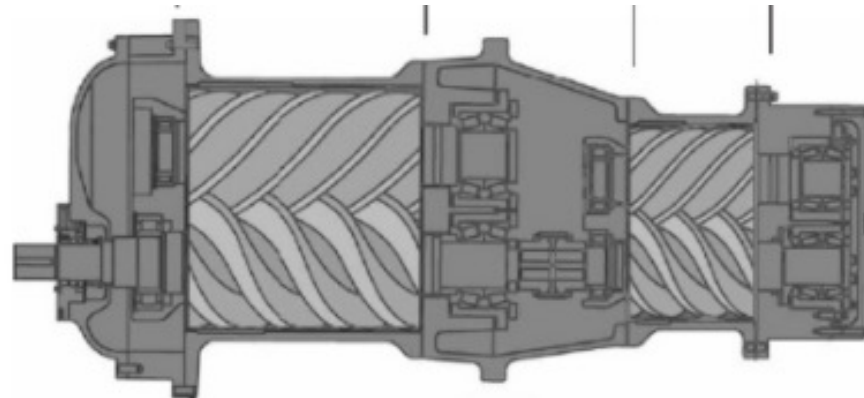

Single Stage Compressor

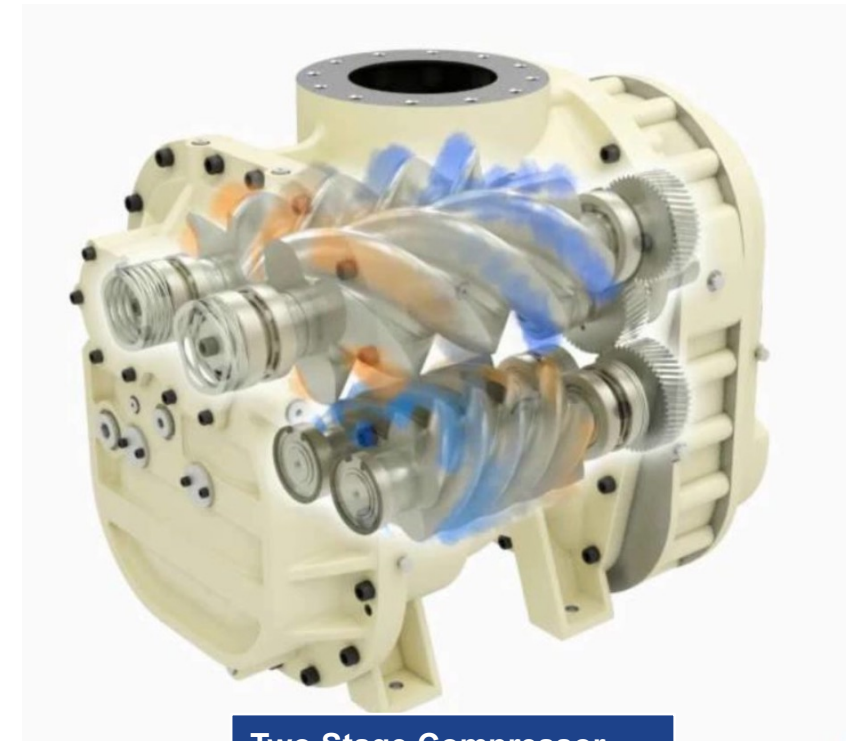
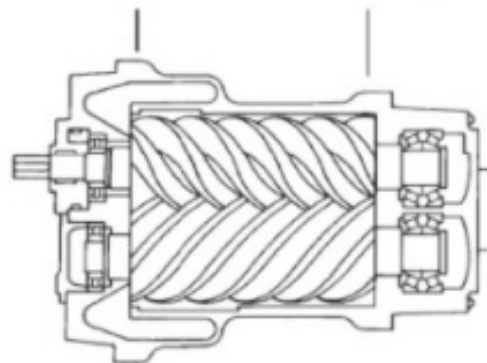

Two Stage Compressor



*Intake-  
14.5 psia*

*Compression  
Ratio-2.8 to 1*

*Interstage-41 psia*

*Compression  
Ratio-  
2.8 to 1*

*Discharge-  
114.5 psia*

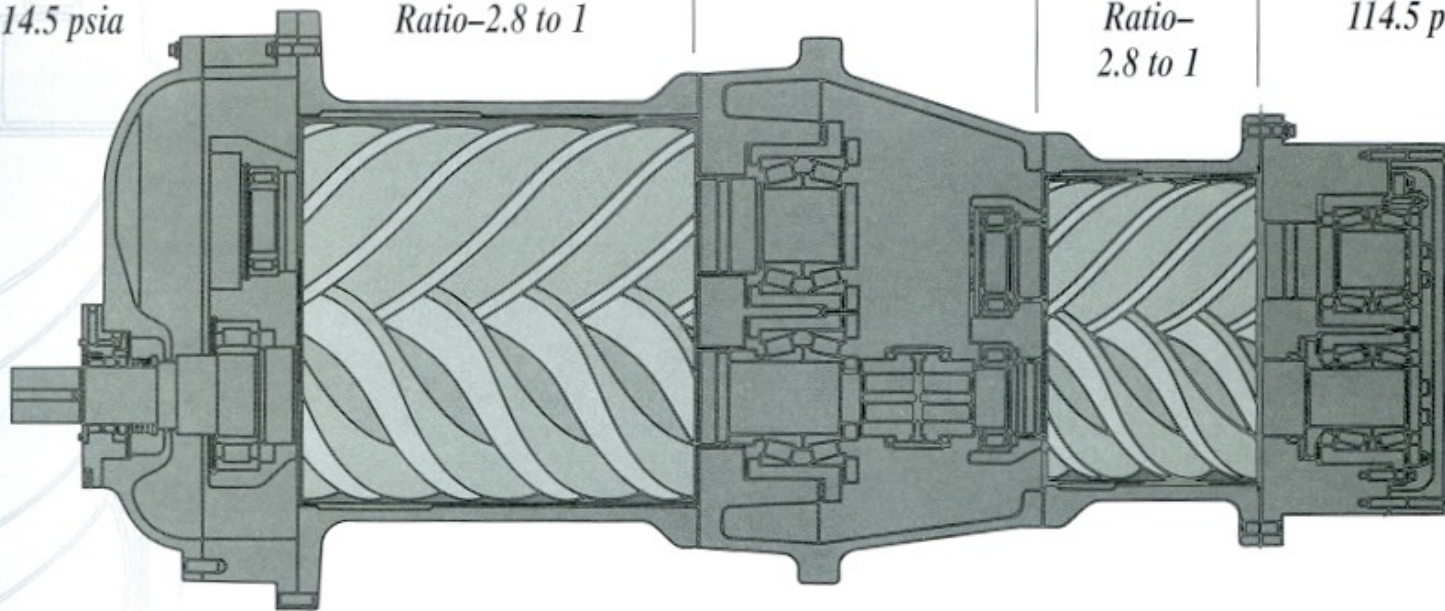

*Intake-  
14.5 psia*

*Compression  
Ratio-7.8 to 1*

*Discharge-  
114.5 psia*

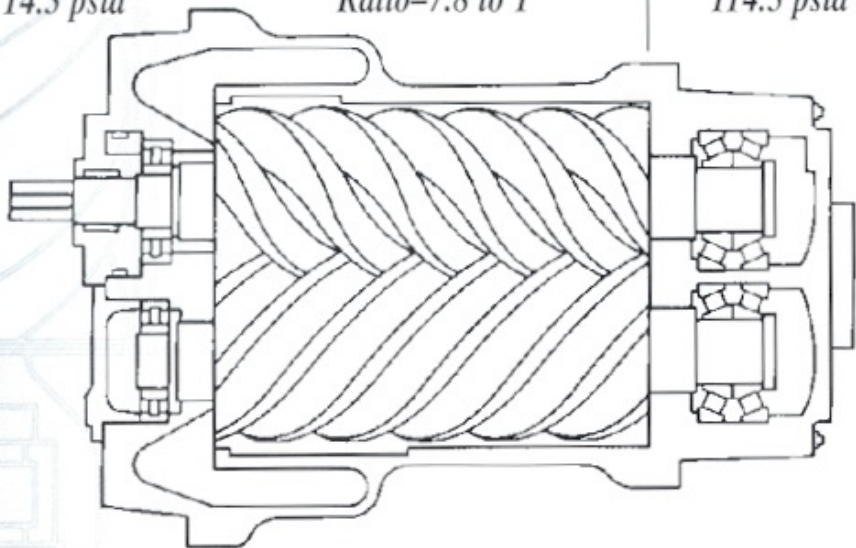

# Two Stage Rotary Screw

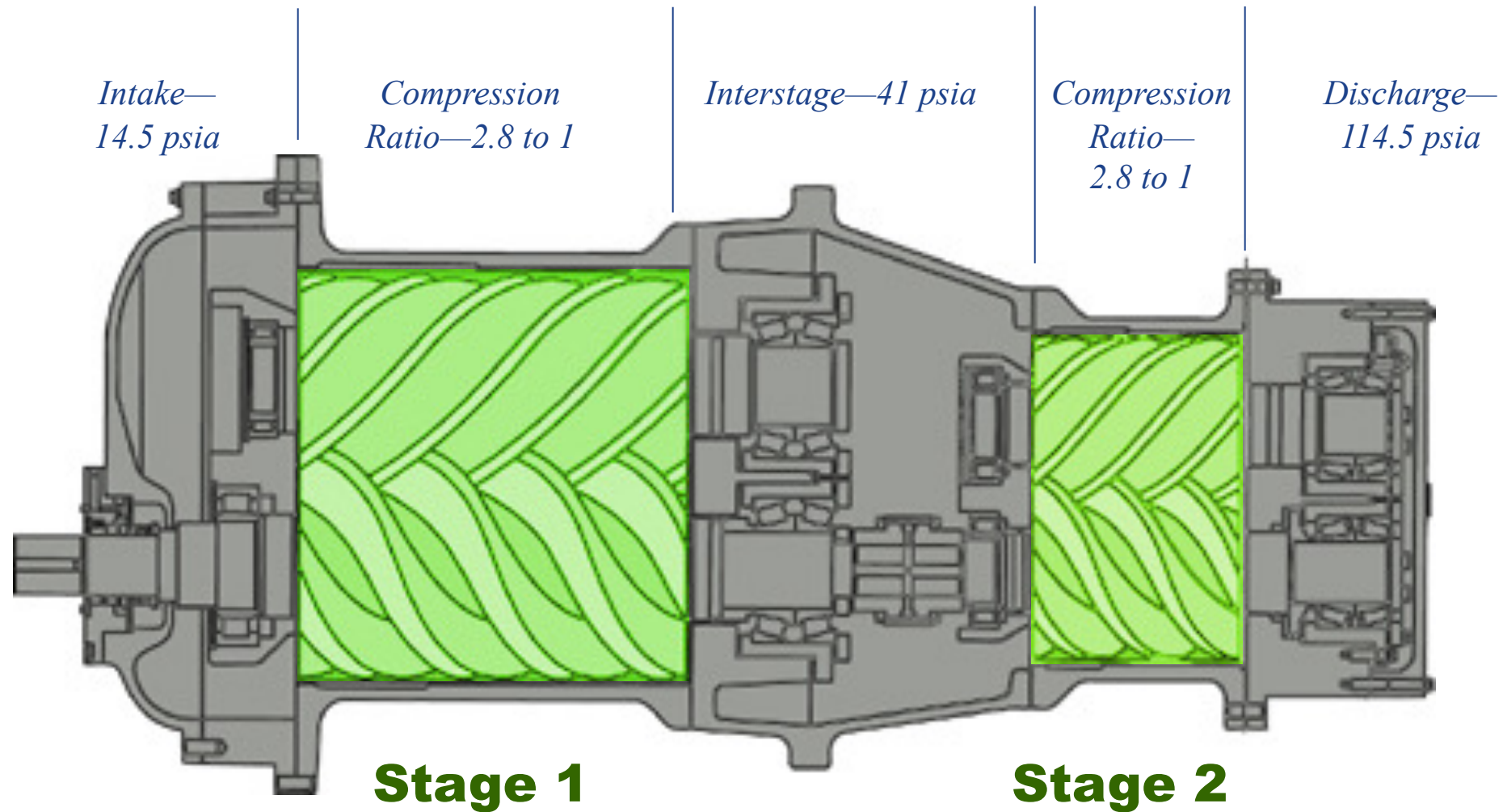

**Two-stage Compressor**

# Oil Free Rotary

- Lubricant-free rotary screw air compressors are also a positive displacement type - Two distinct designs are available:

Dry Rotary Screw

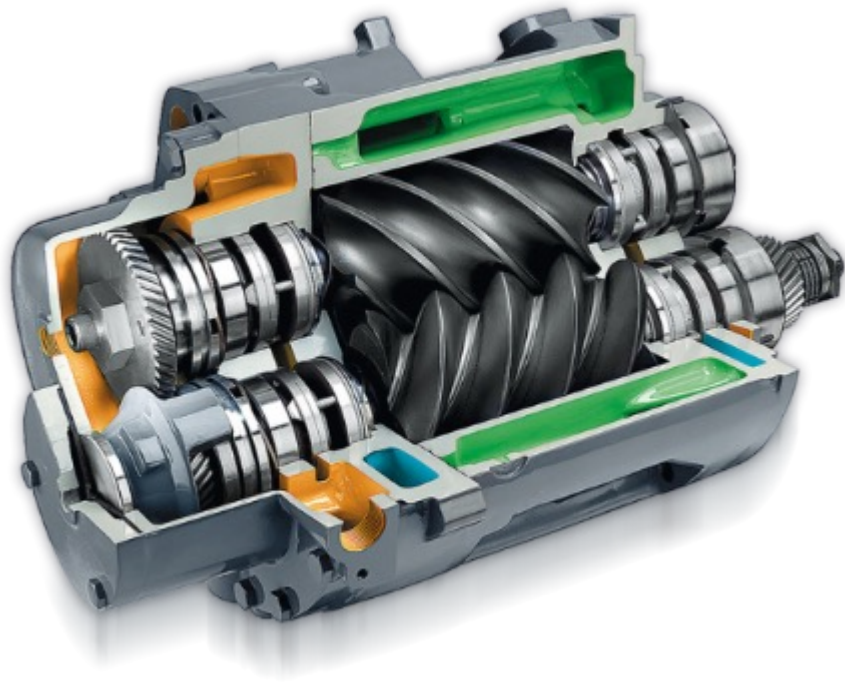

Water Injected Screw

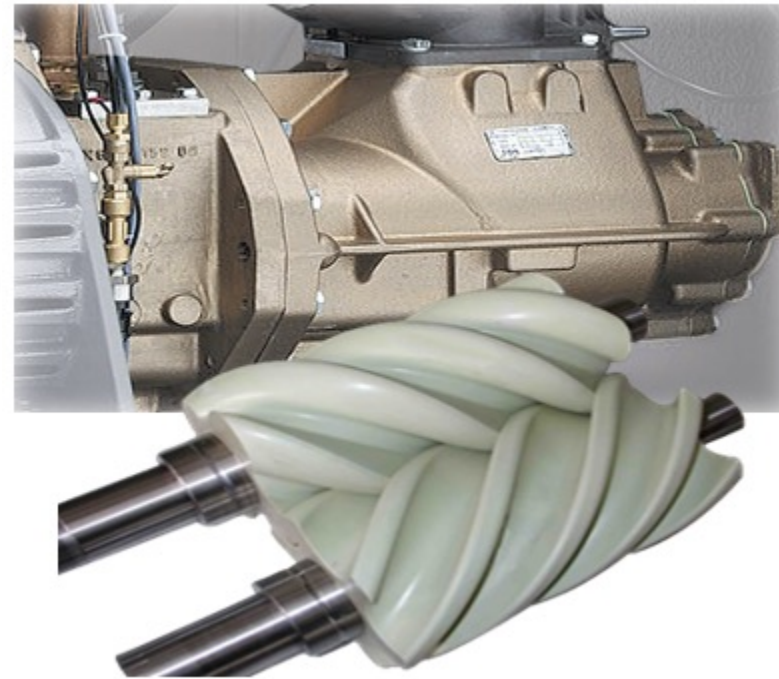

# Lubricant-Free Rotary Screw Compressors



- Since there is no injected fluid to remove the heat of compression as done with lubricant injected two stage compressors, most oil free designs use two stages of compression, with an intercooler between the stages and an aftercooler after the second stage.
- Operating efficiency: **18-22 kW/100 cfm**

# Oil Free Rotary

- Dry-type lubricant-free rotary screw compressors have a range up to 1,200 horsepower and over 5,000 CFM
- Single-stage units can operate up to 50 psig, while two-stage compressors can generally achieve 150 psig.

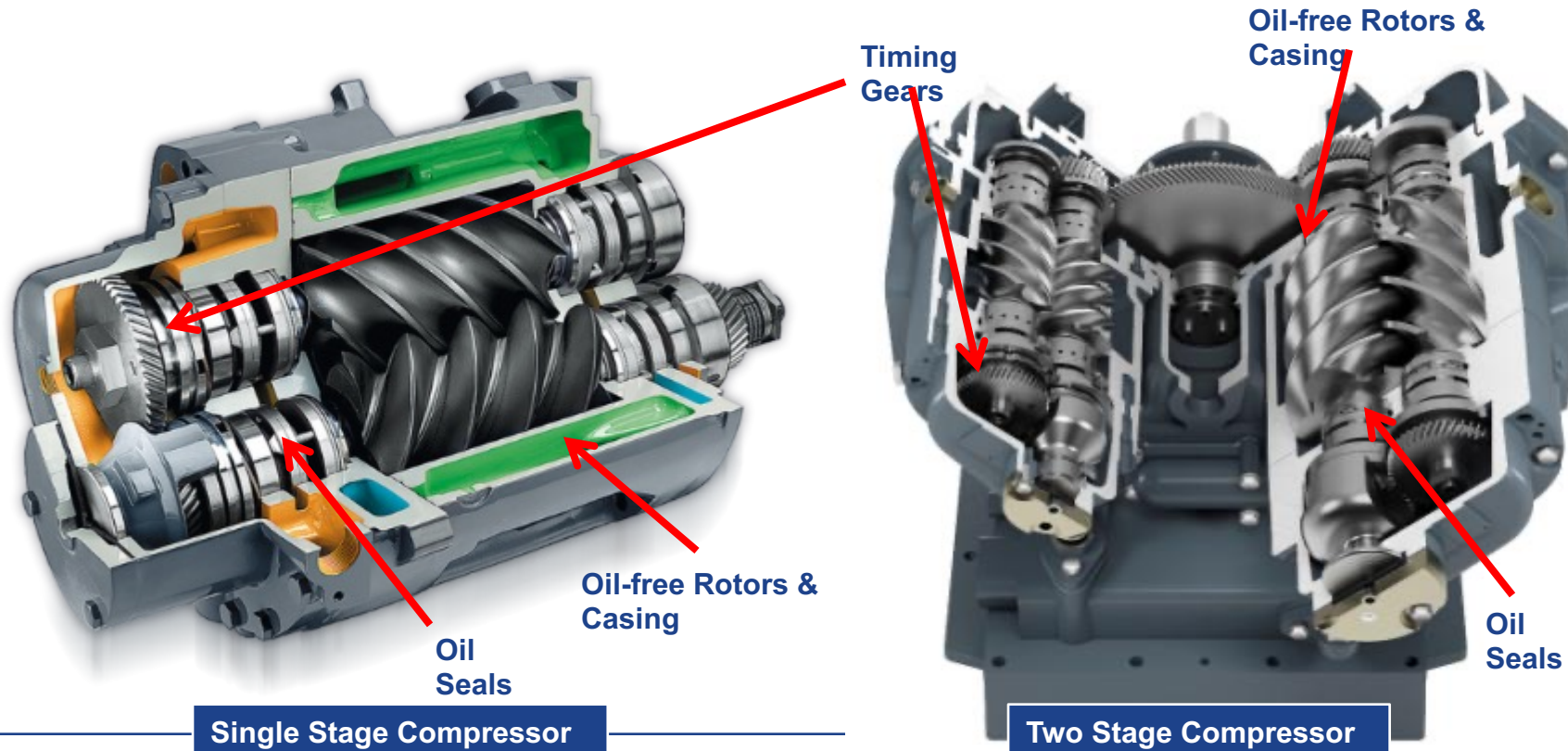

# Oil Free Rotary

- Lubricant-free rotary screw compressors 'do' utilize lubricants but it's main purpose is to lubricate bearings, gears and supply casing jacket cooling to help prevent casing thermal growth.

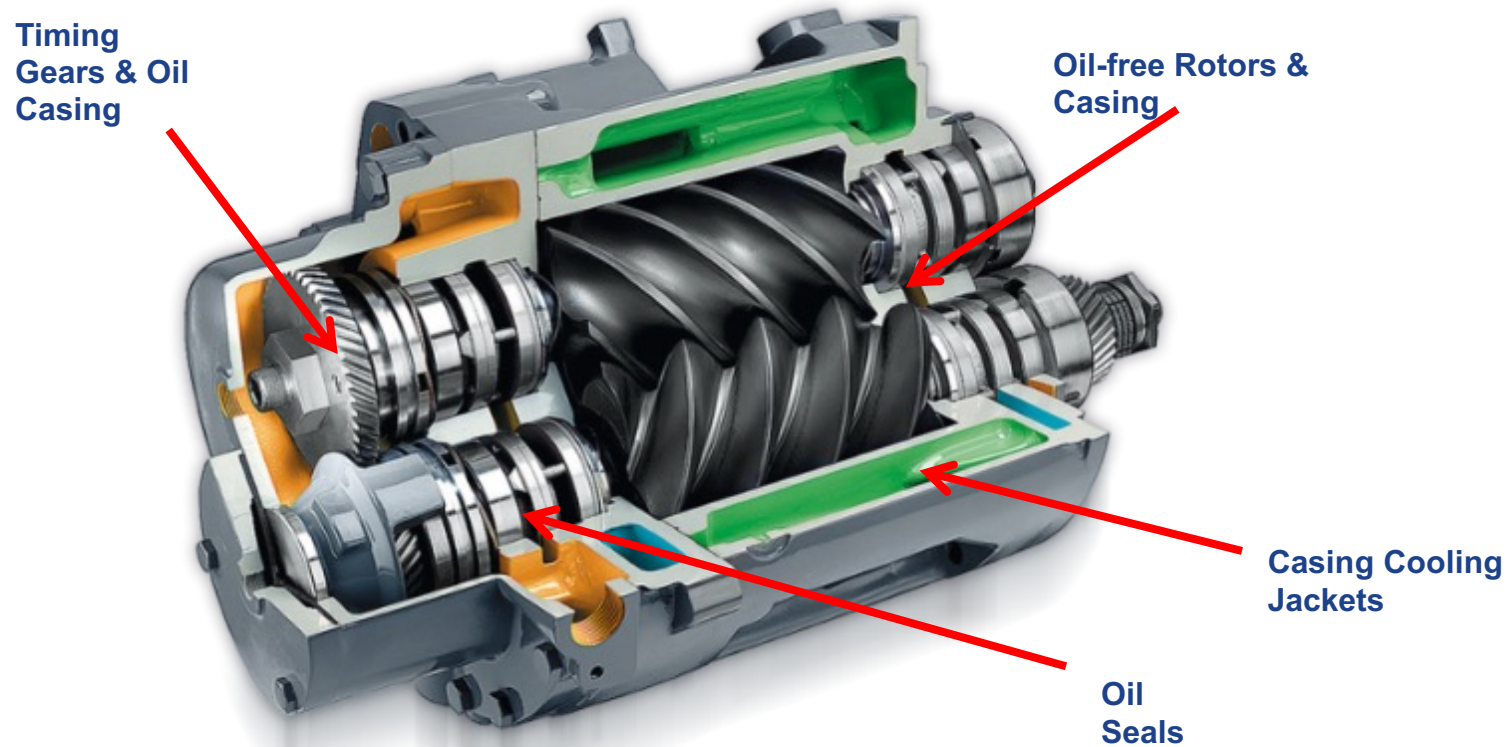

# Oil Free Rotary

- With water injected rotary screw compressors – liquid (water) is used for cooling, sealing and lubrication. This coolant in the compression chamber allows these single stage designs to operate at higher pressures (150 to 190 psig)

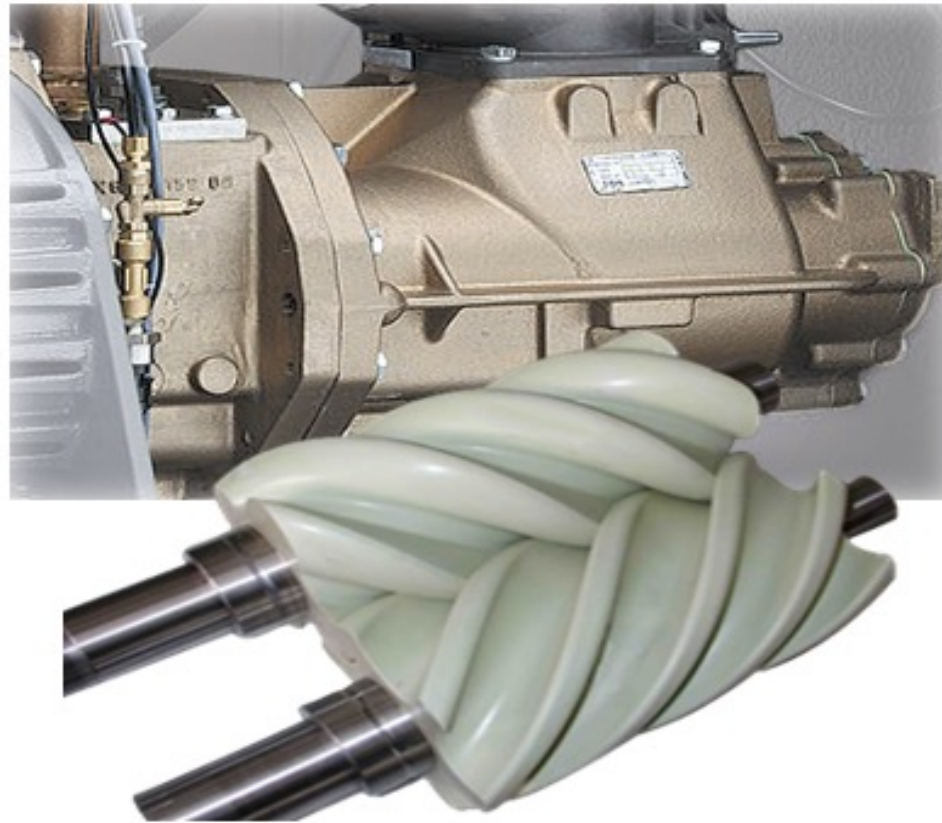

# Dynamic Compressors - Centrifugal

- Centrifugal compressors operate on a very converts air velocity into an increase in air p
- In a centrifugal compressor, the velocity of increased by the rotating impeller.
- The velocity is increased by centrifugal force
- A centrifugal compressor's output capacity a directly related to the rotational speed of the impeller is mounted.





# Dynamic Compressors

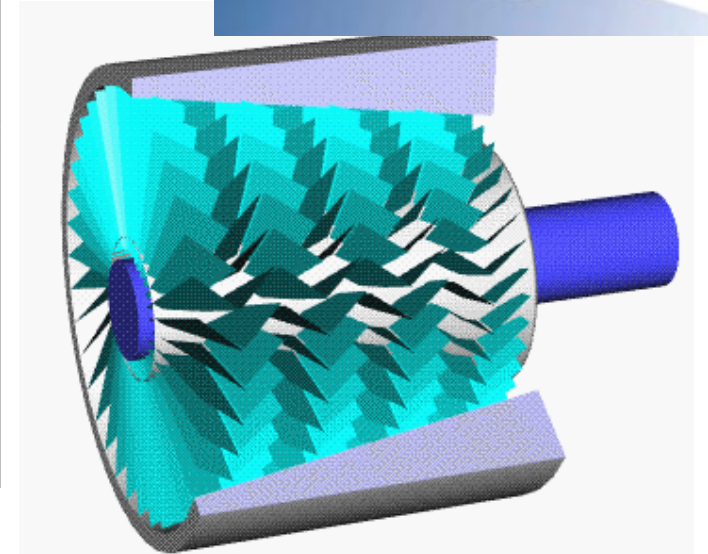
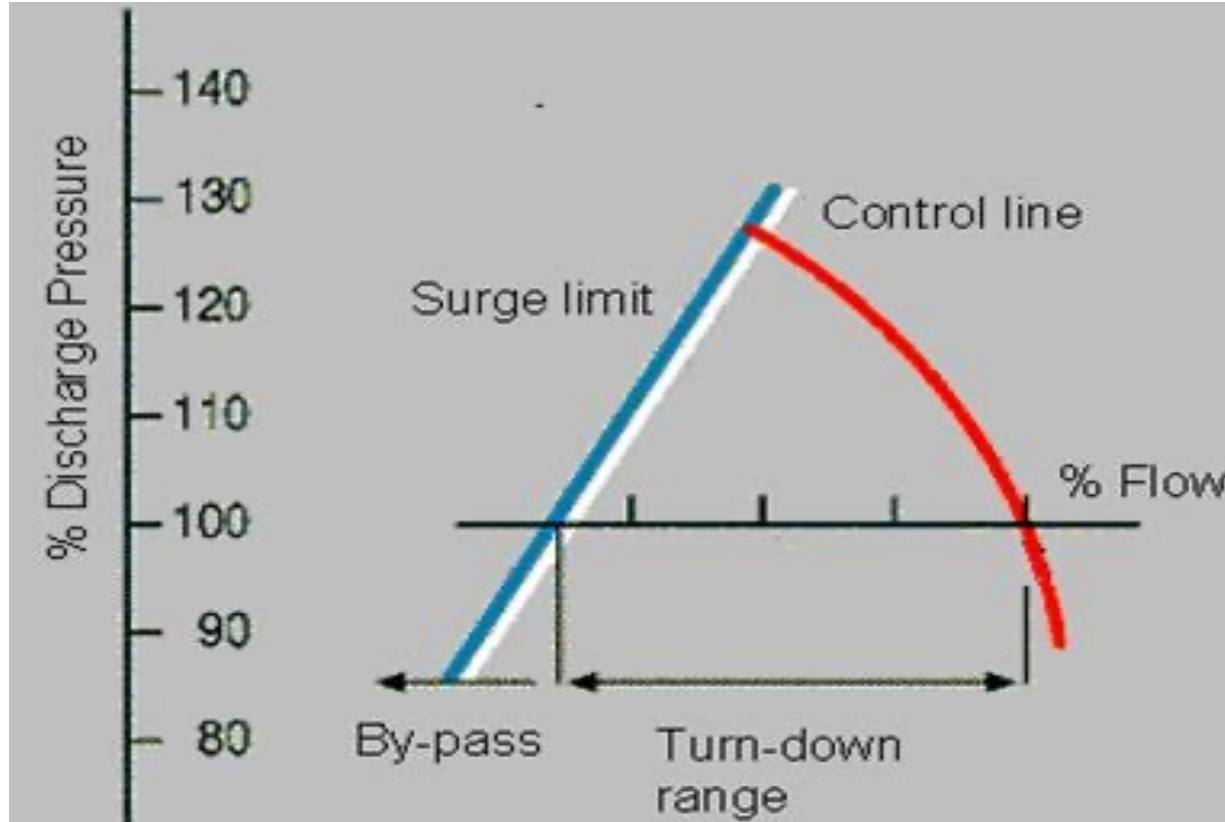

# Inlet Guide Vanes – Open and Closed



## Energy Savings INLET GUIDE VANE versus BUTTERFLY VALVE 3-Stage Compressor at Constant 100% Pressure

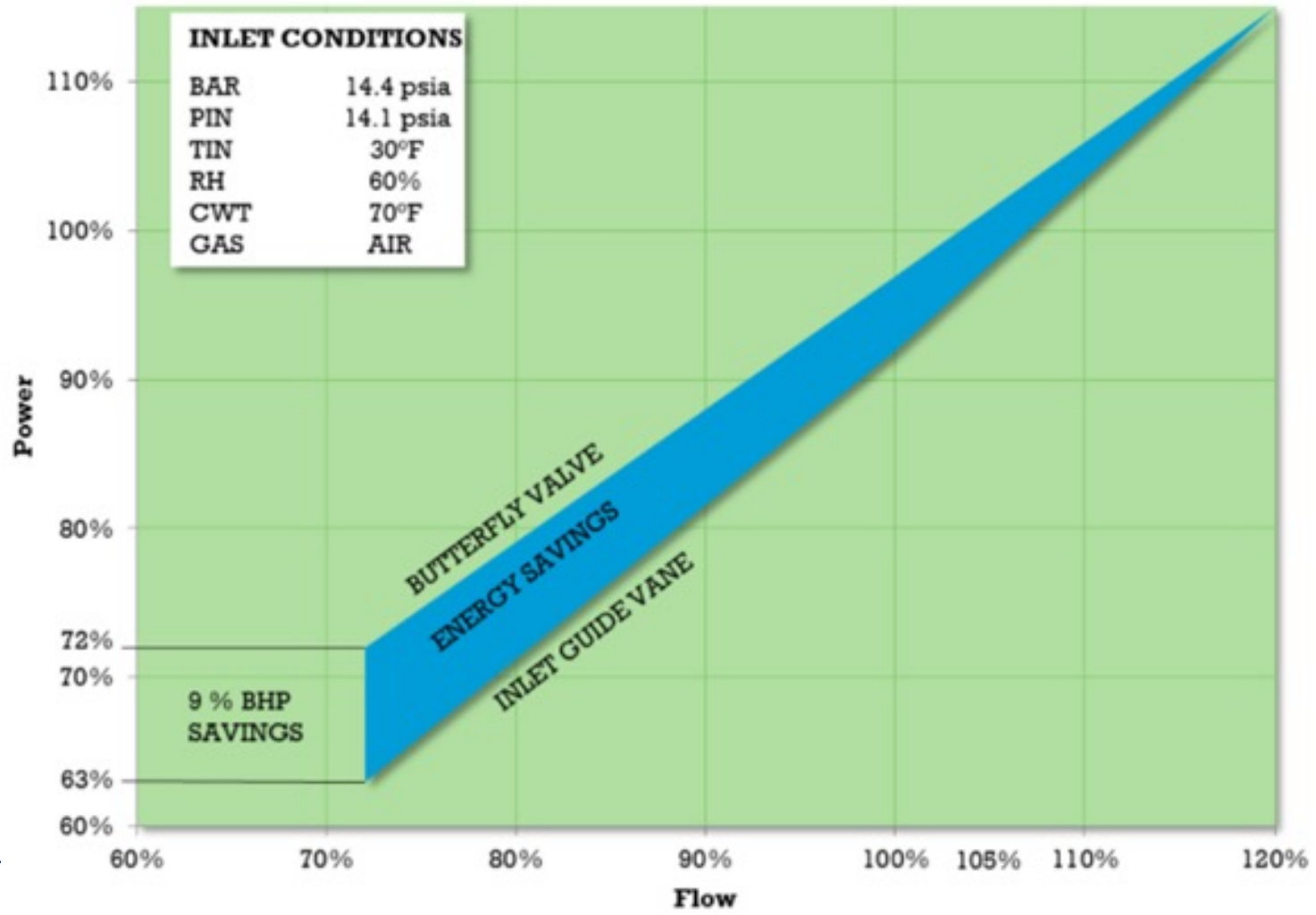

INLET CONDITIONS	
BAR	14.4 psia
PIN	14.1 psia
TIN	30°F
RH	60%
CWT	70°F
GAS	AIR

# Dynamic Comrpressors

- Dynamic-type compressors are compressors in which air or gas is compressed by mechanical action of rotating impellers. Centrifugal compressors are Dynamic type.

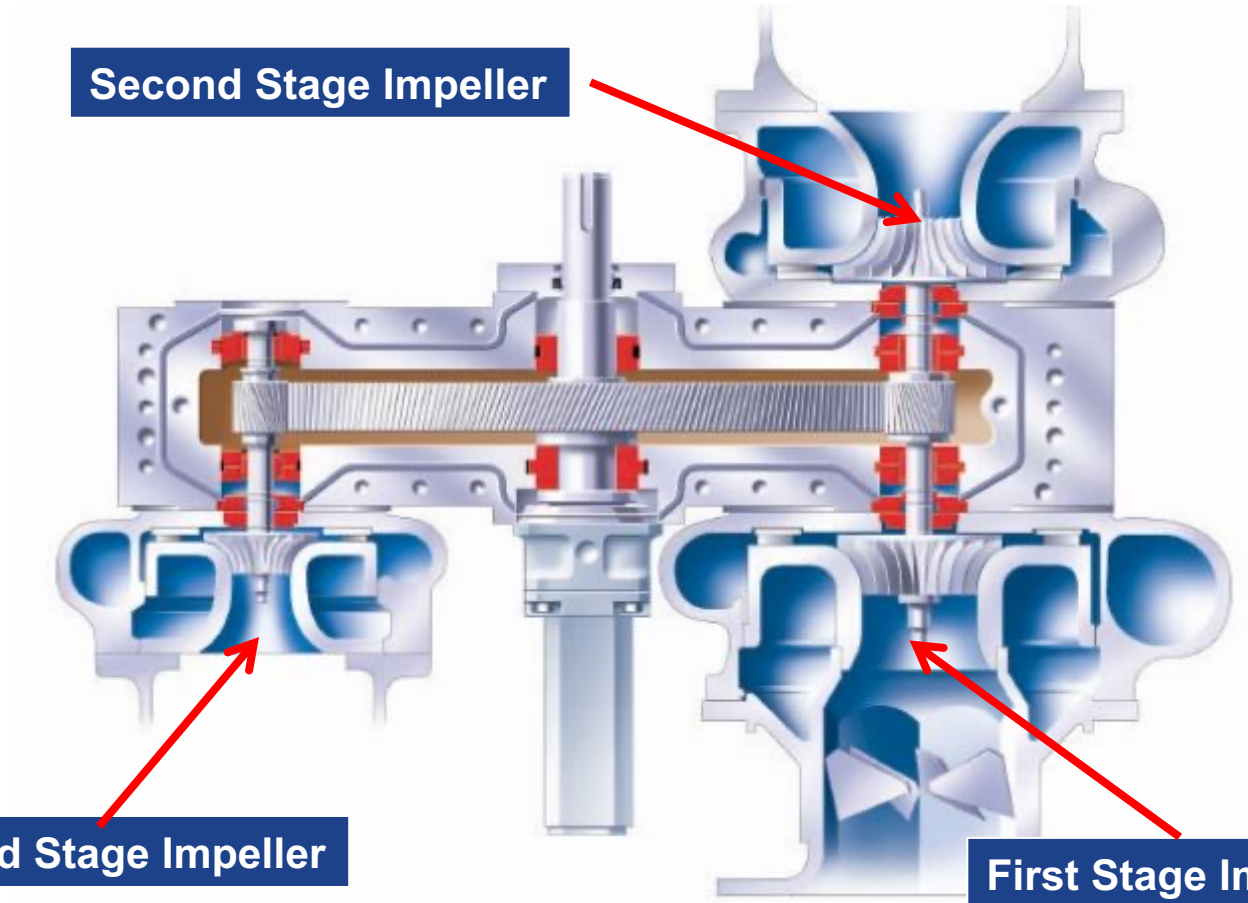



# Centrifugal Compressor



# Centrifugal Compressor Terminology

SCROLL VOLUTE

IMPELLER

DIFFUSER

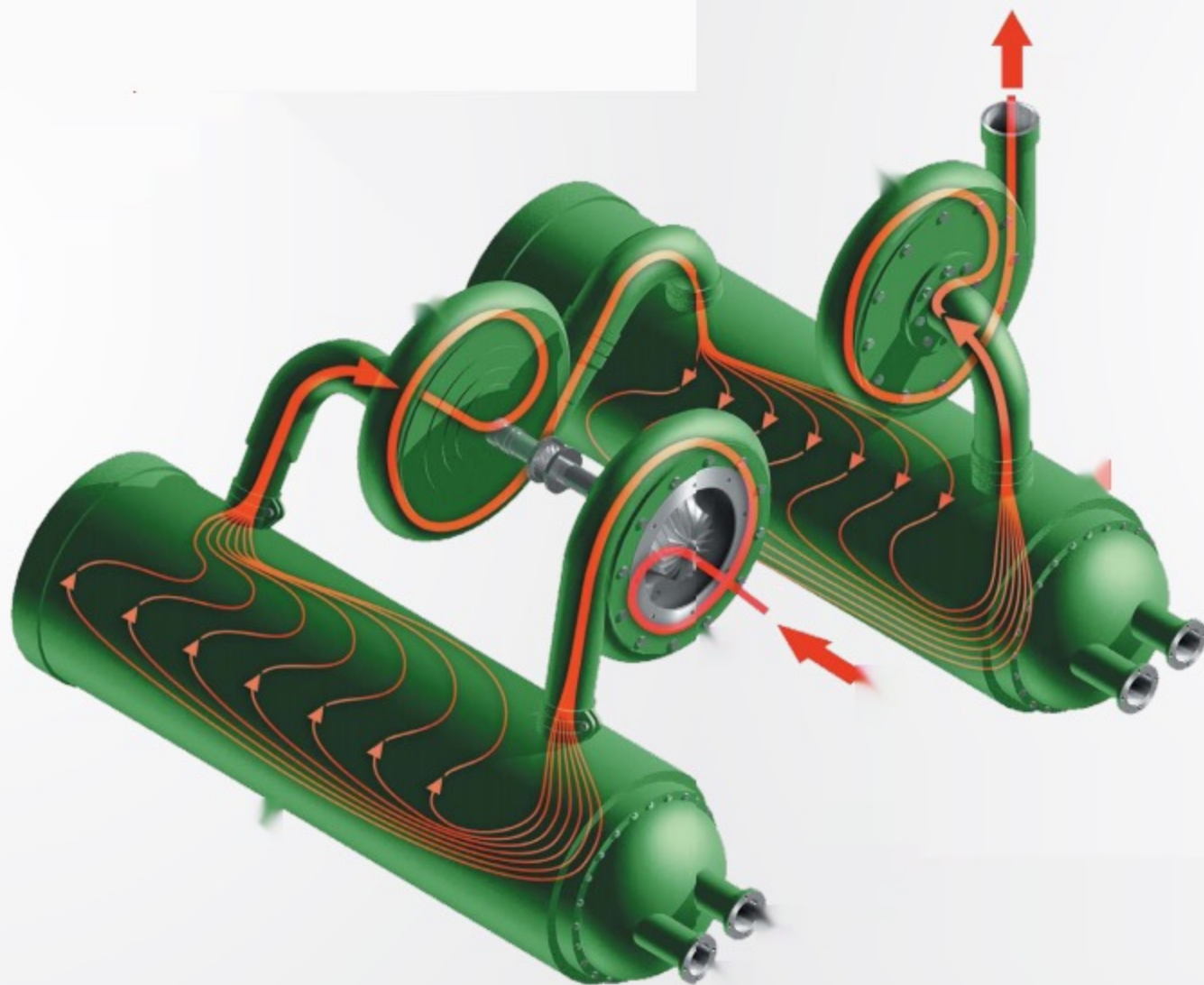
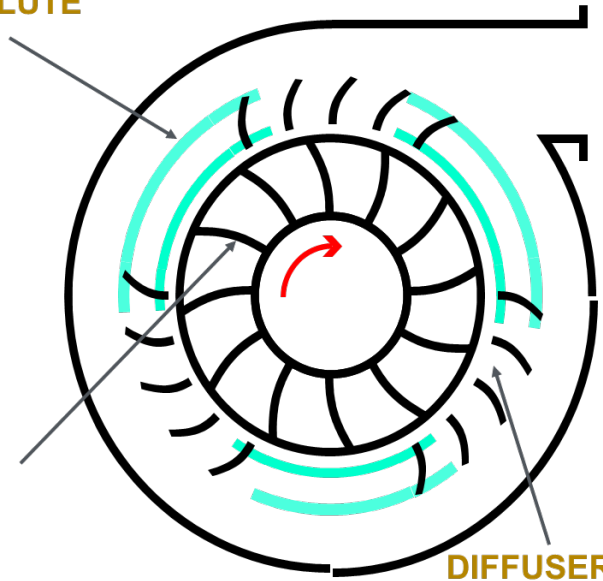

# Three Stage

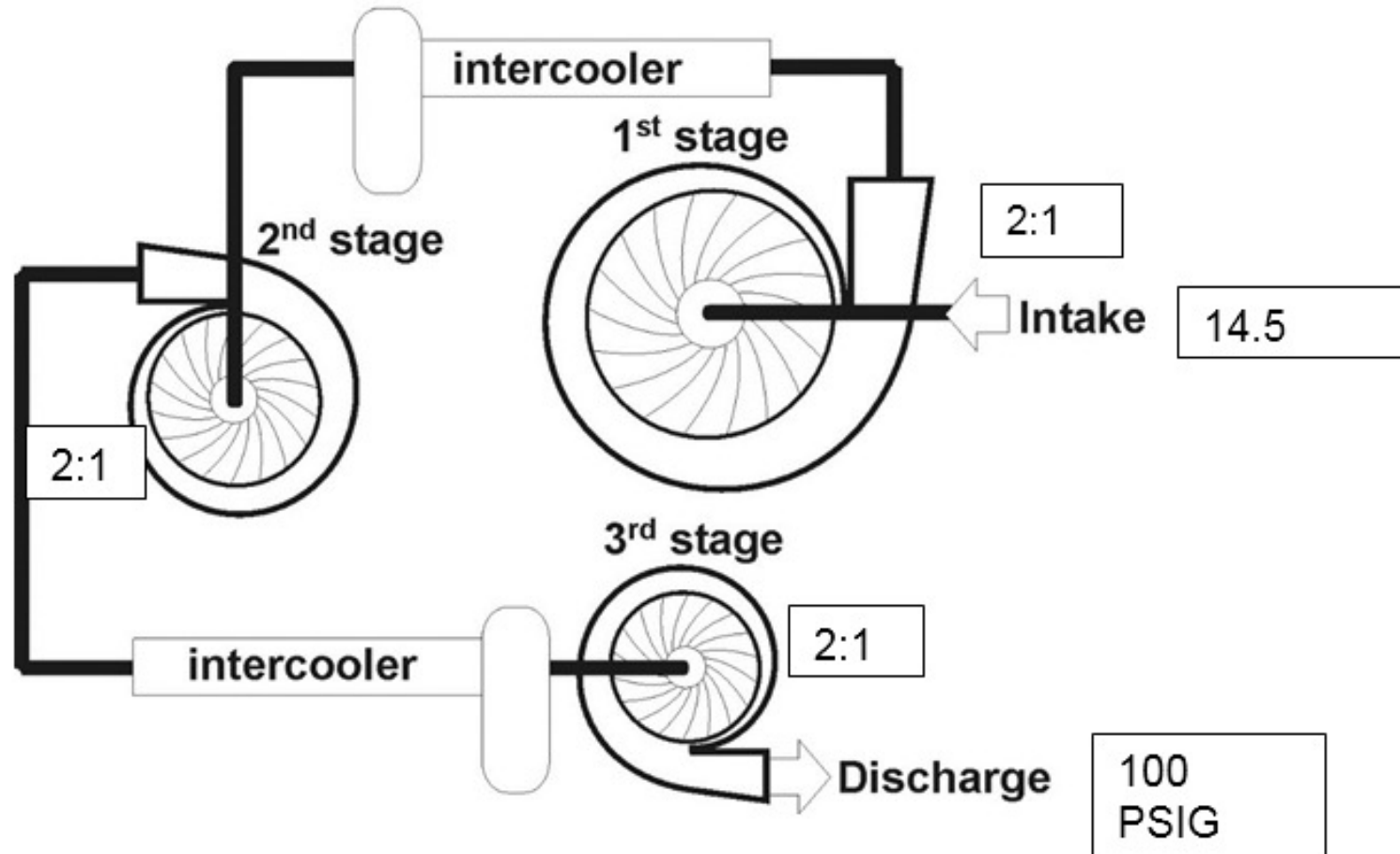

Exact Form:  
 $\sqrt[3]{7.8}$   
Decimal Form:  
1.98319248...

Multi stage centrifugal compressors are designed to try and balance the load between stages



# Effects on dynamic compressor performance

- Inlet pressure
- Inlet air temperature
- Cooling water temperature

# Centrifugal Compressor Control Derived from Water Pump

## Head Vs Flow Curve (H-Q Curve)

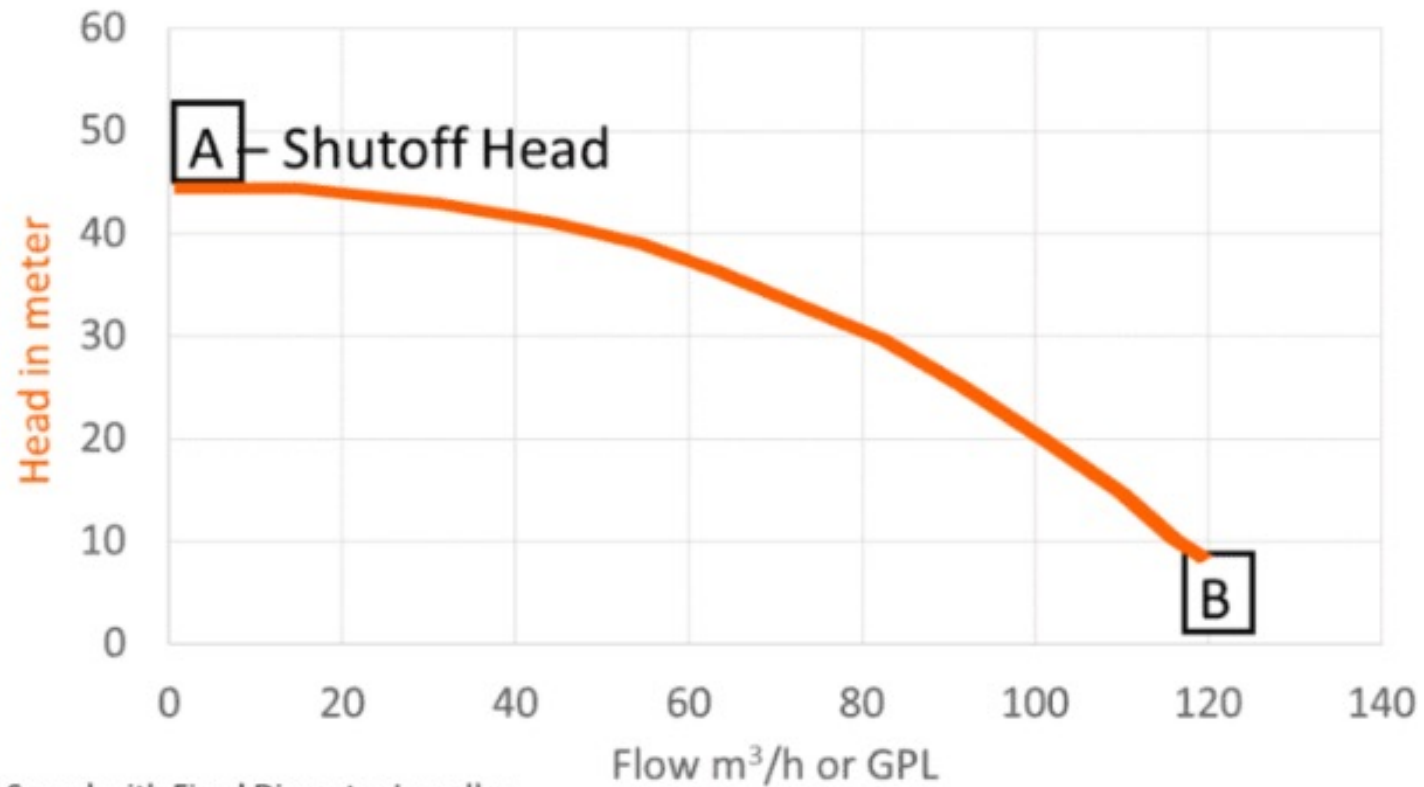

Constant Speed with Fixed Diameter Impeller

Visit Today - [www.hardhatengineer.com](http://www.hardhatengineer.com)

# Centrifugal Compressor Control

- Nomenclature

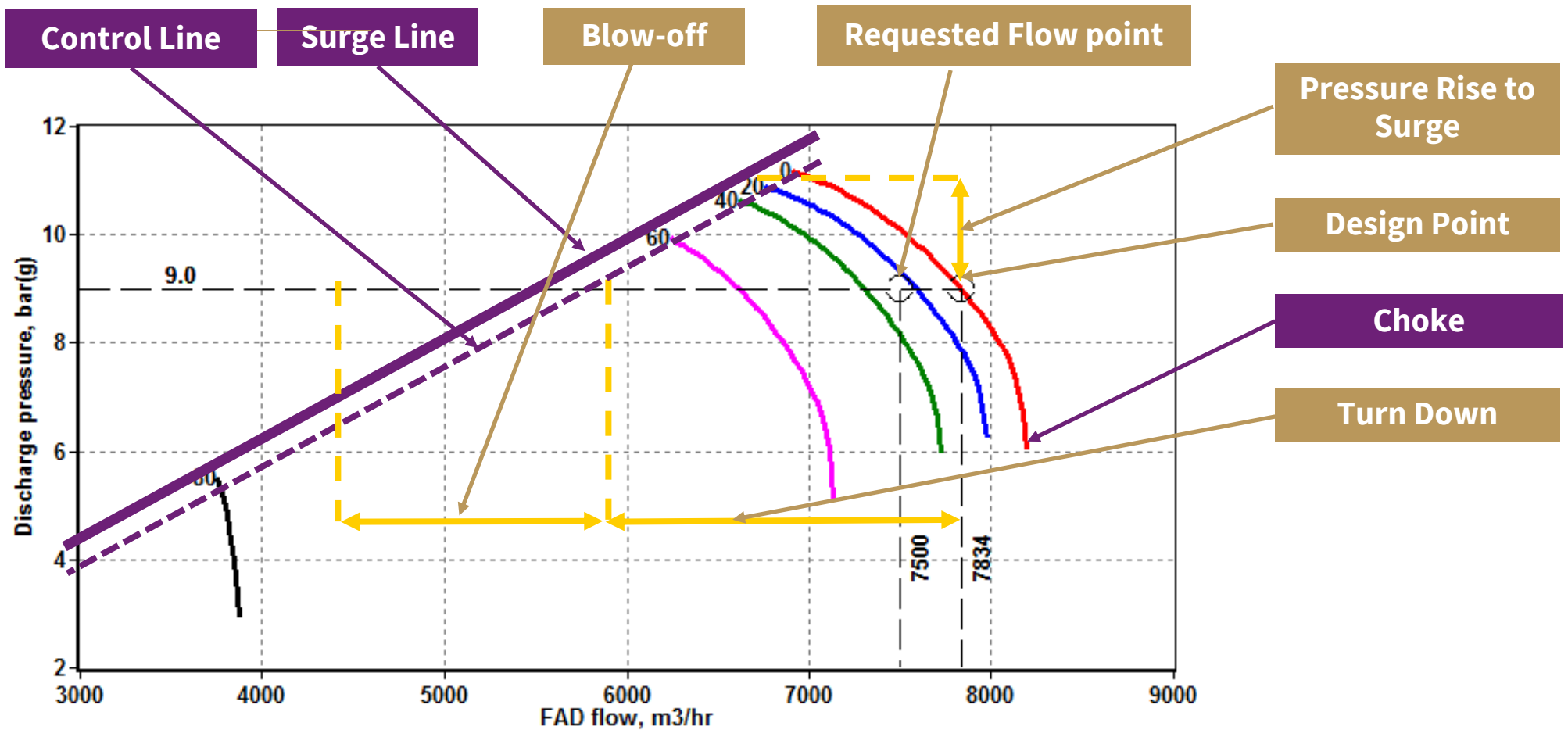

Curve showing air compressor performance at a 95°F inlet and 110 psig discharge pressure:

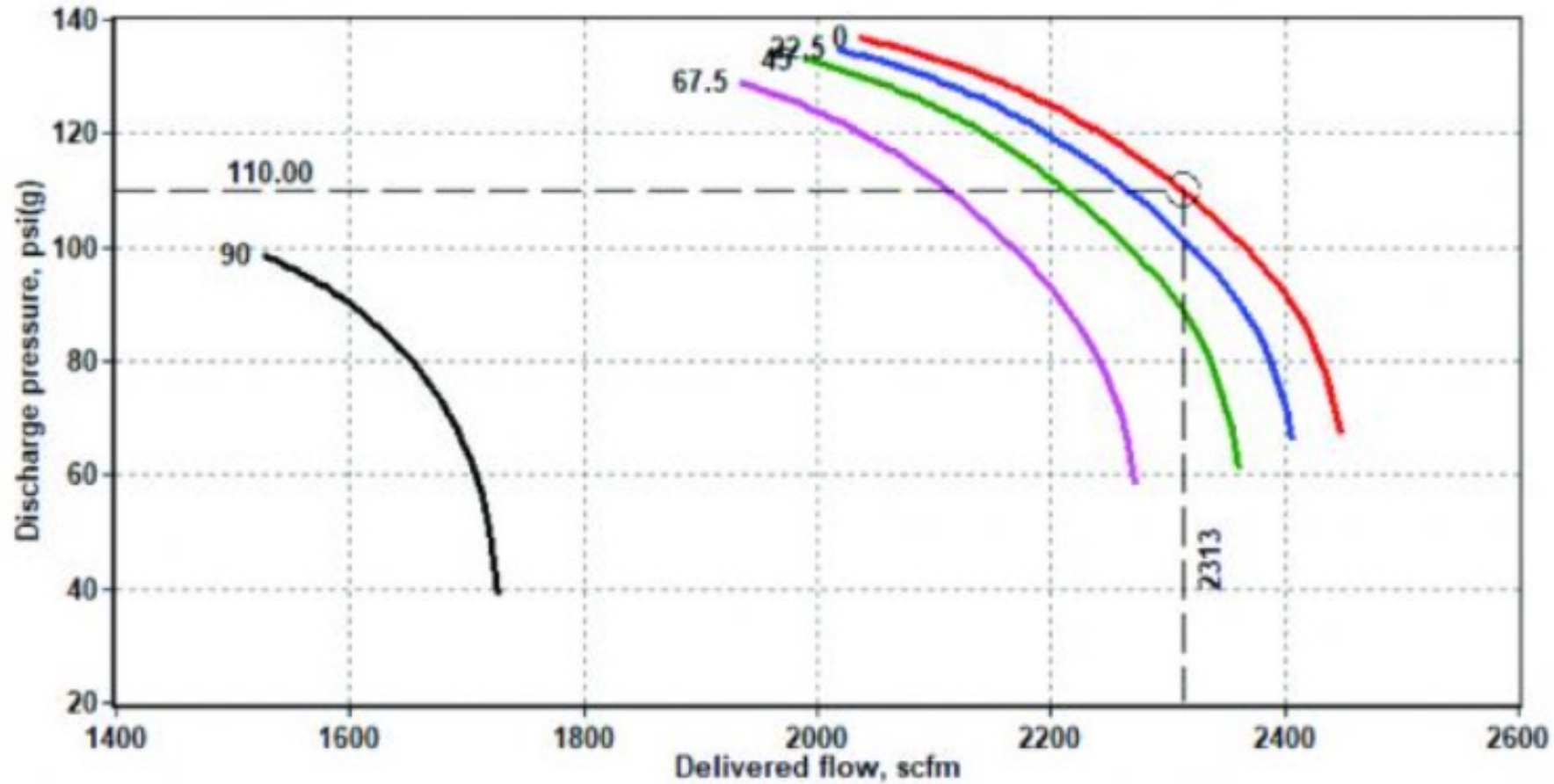

# Curve showing air compressor performance at a 119°F inlet and 110 psig discharge pressure:

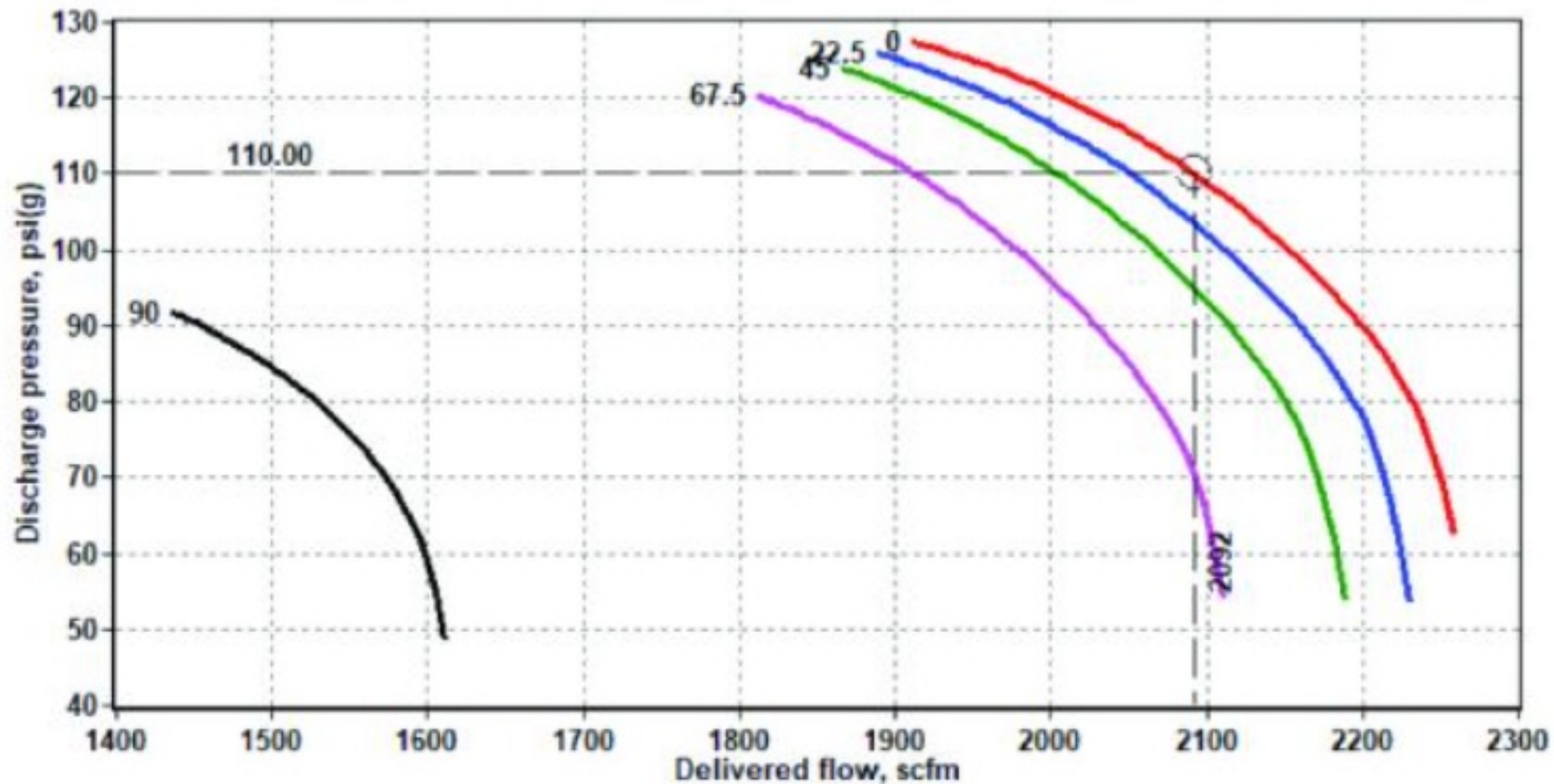

# Effects on dynamic compressor performance

## Inlet pressure

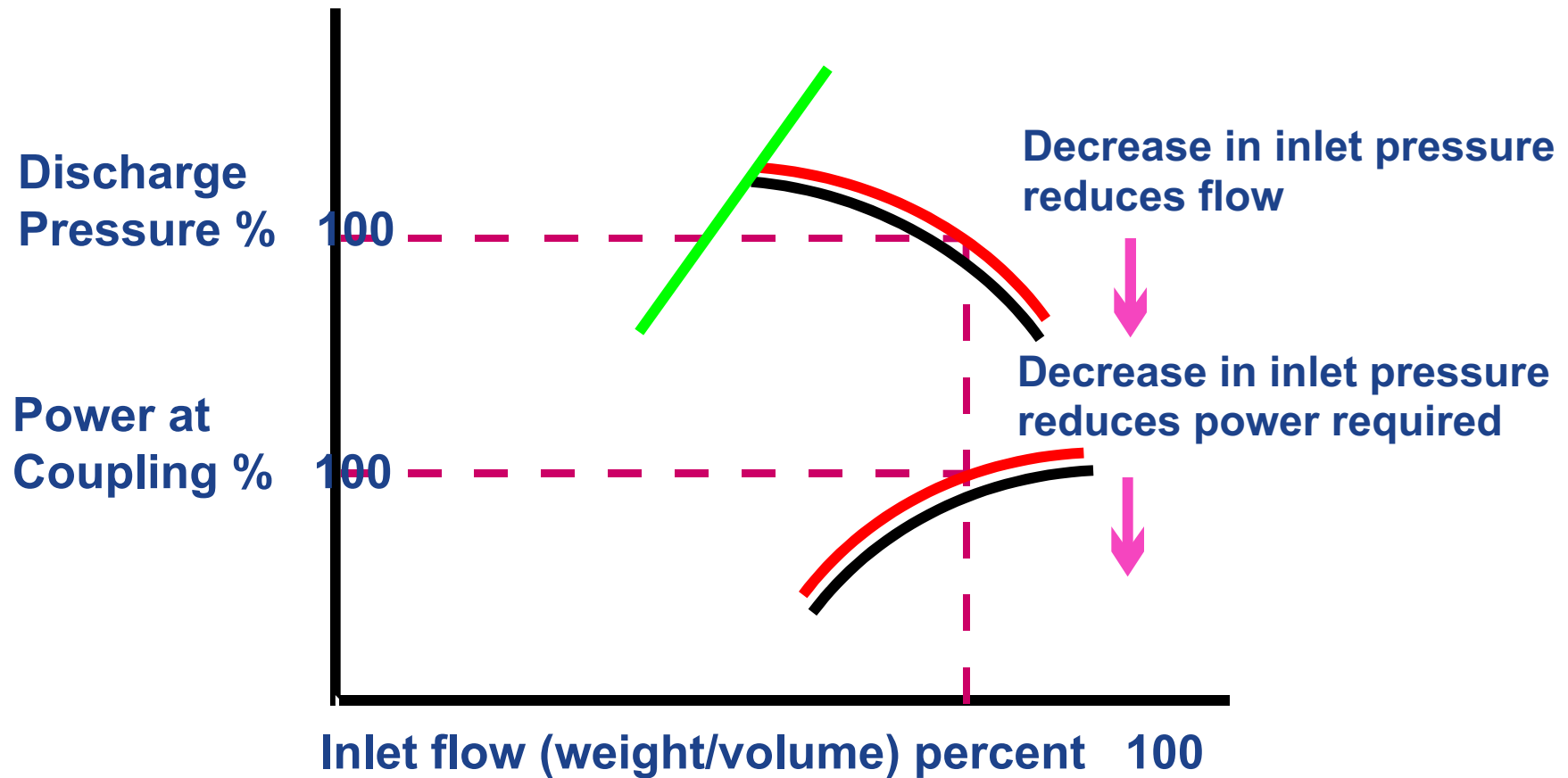

# Effects on dynamic compressor performance

## Inlet air temperature influence

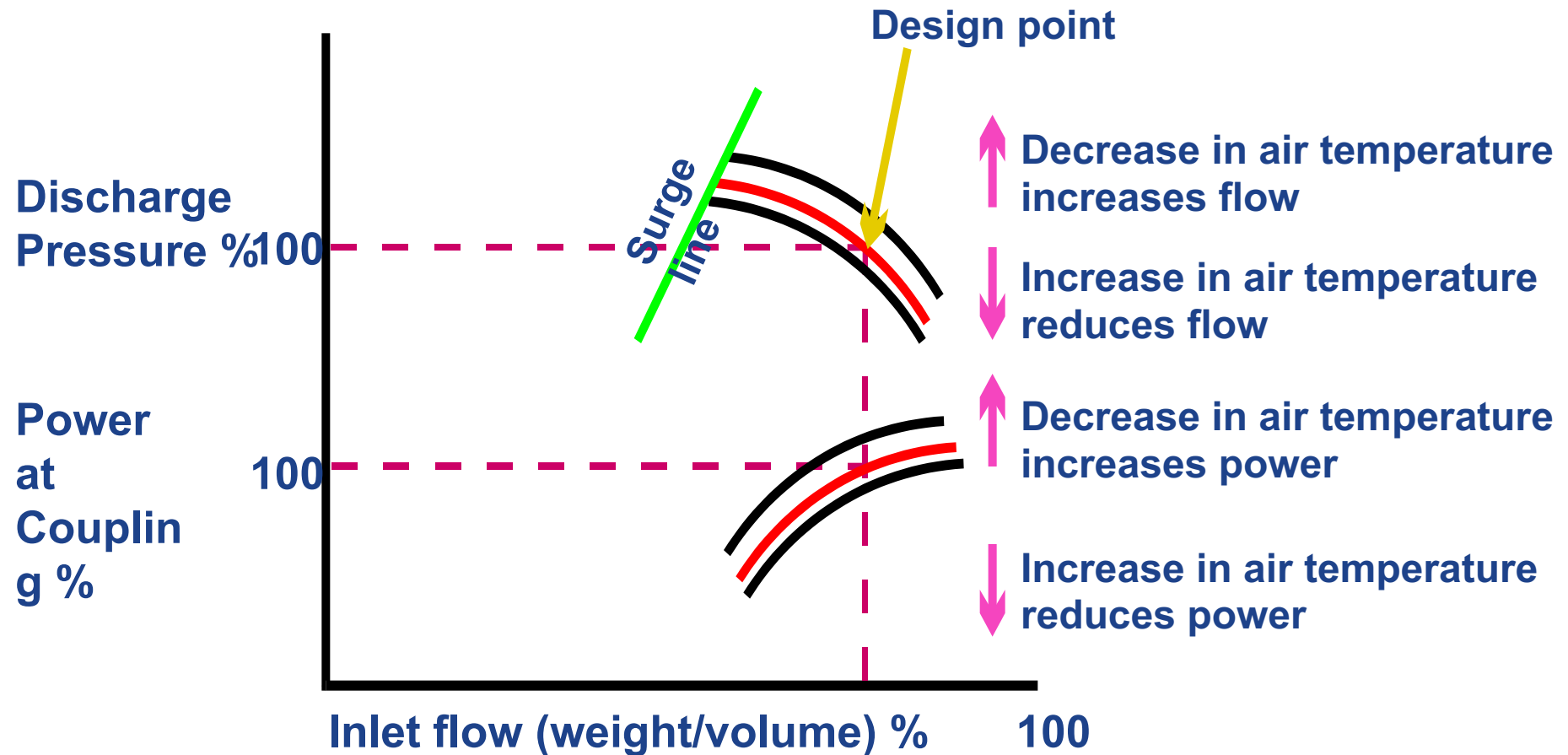

# Effects on dynamic compressor performance

## Cooling water temperature

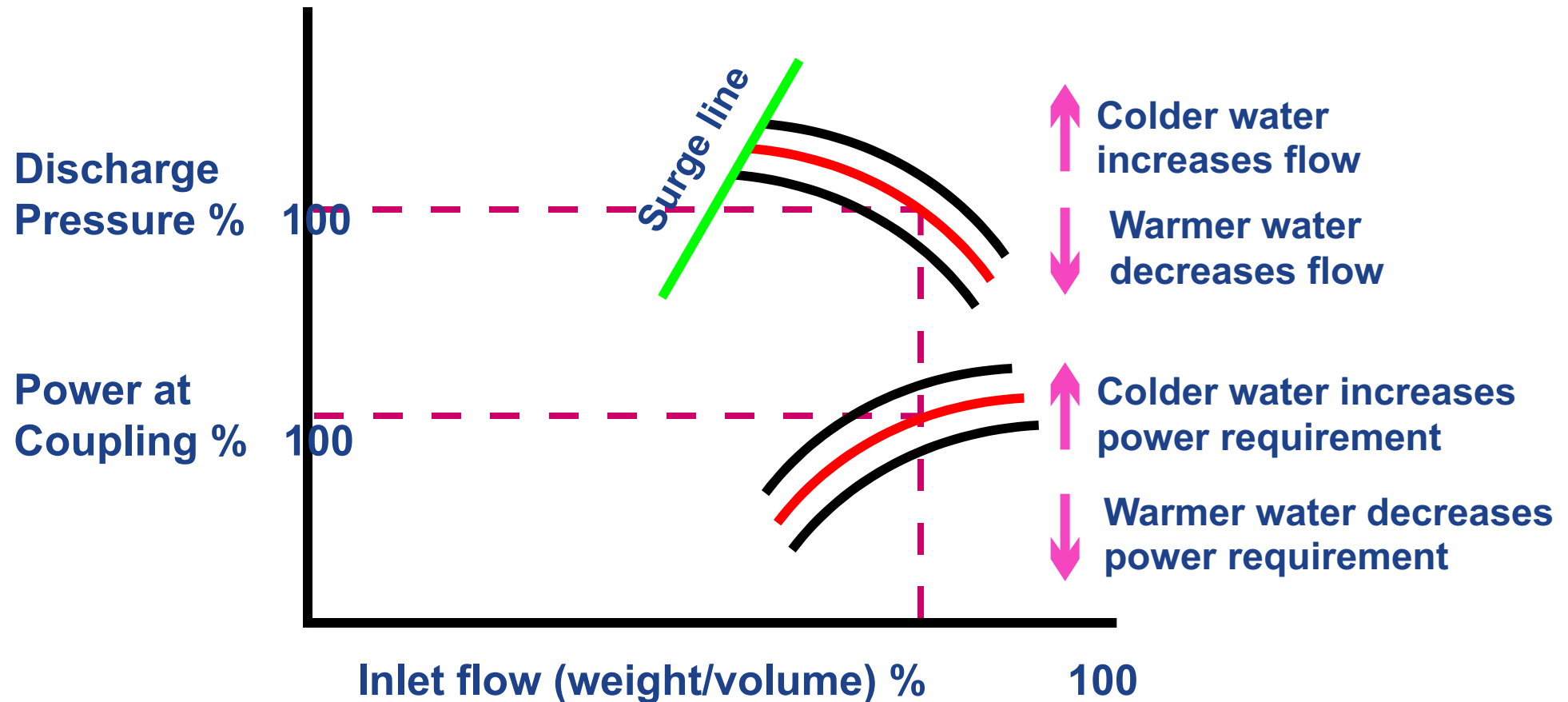



# Centrifugal Compressor Terminology

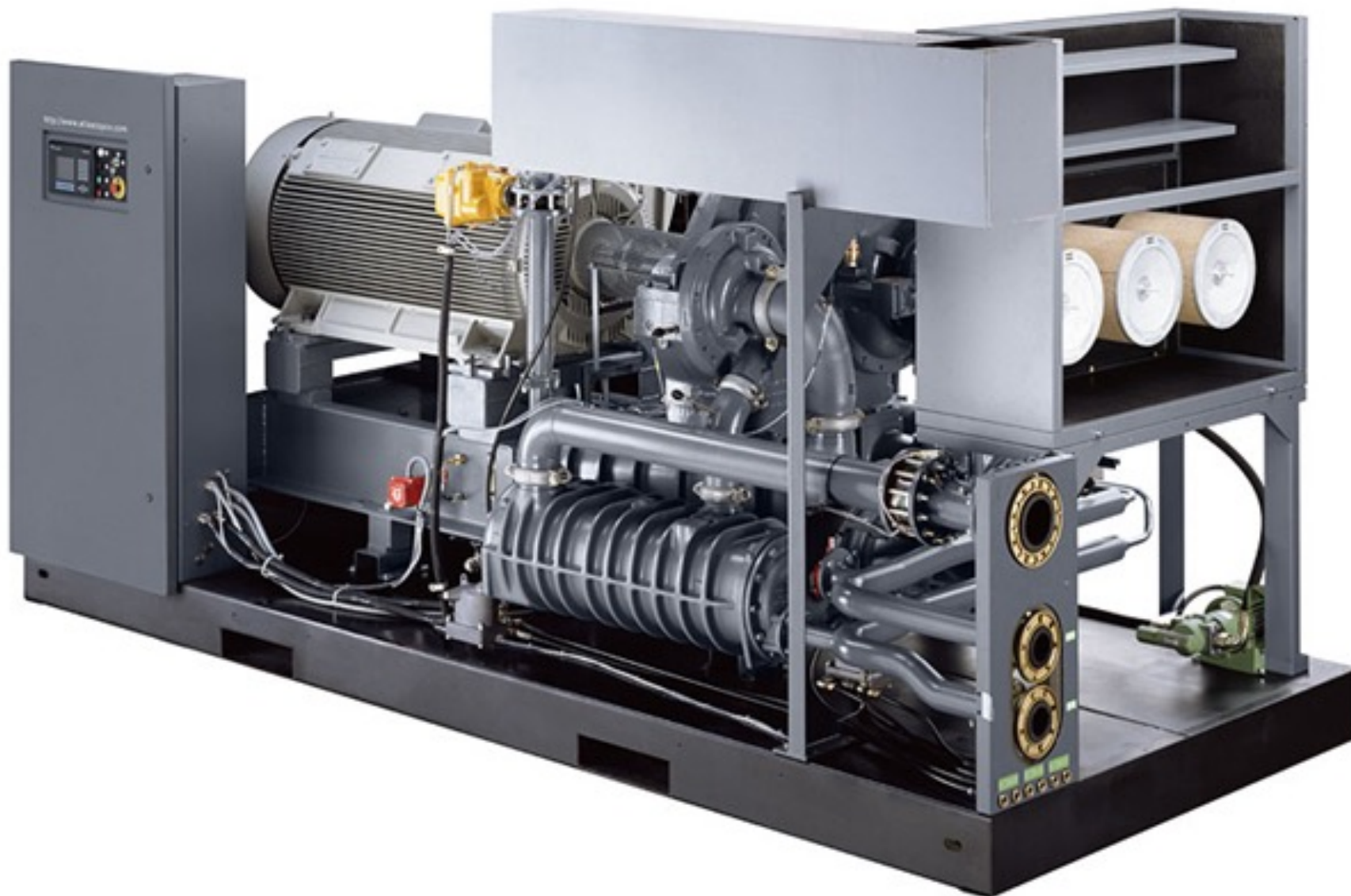

# Centrifugal Compressor Terminology

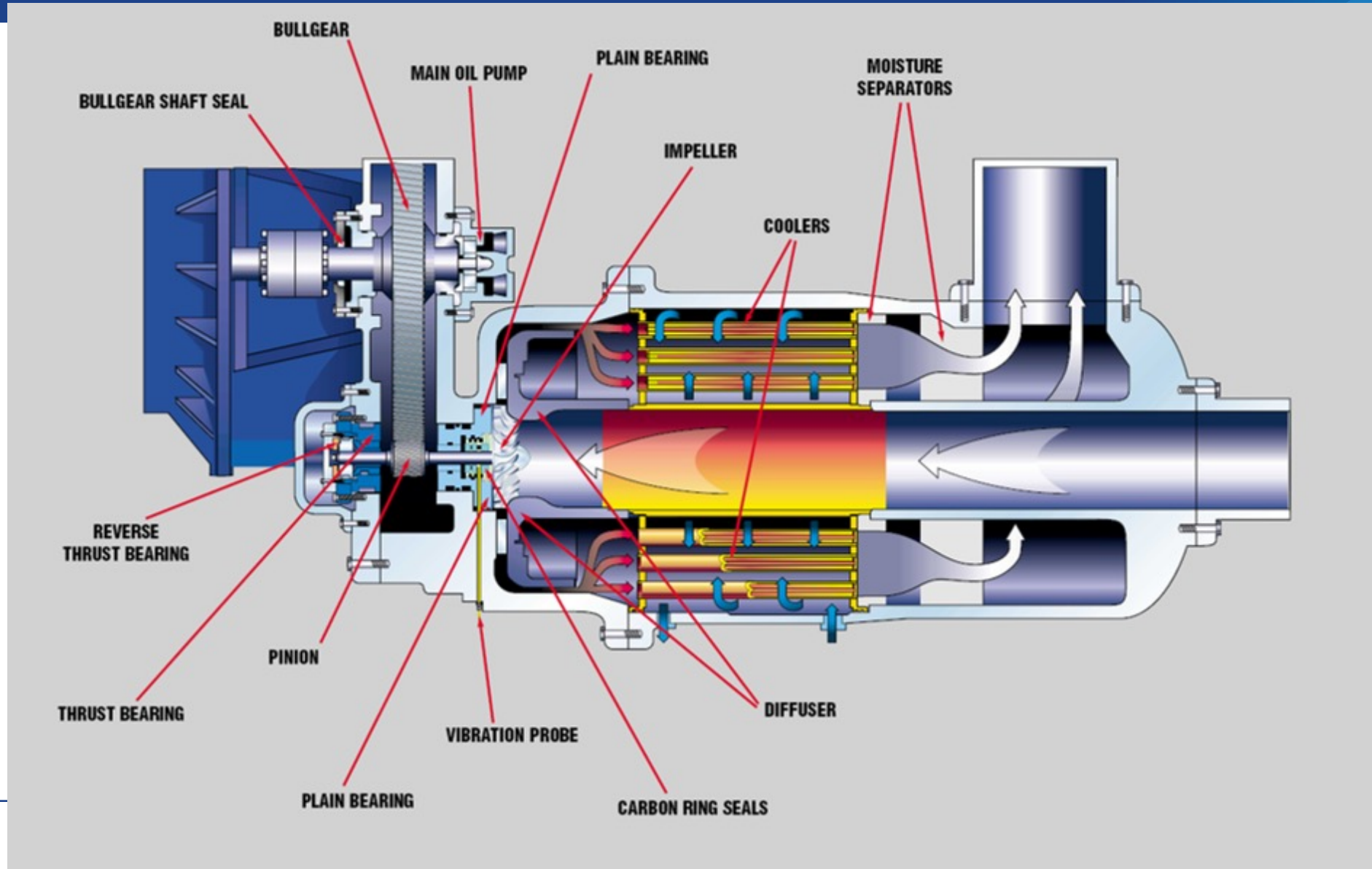

# Centrifugal Compressor Terminology

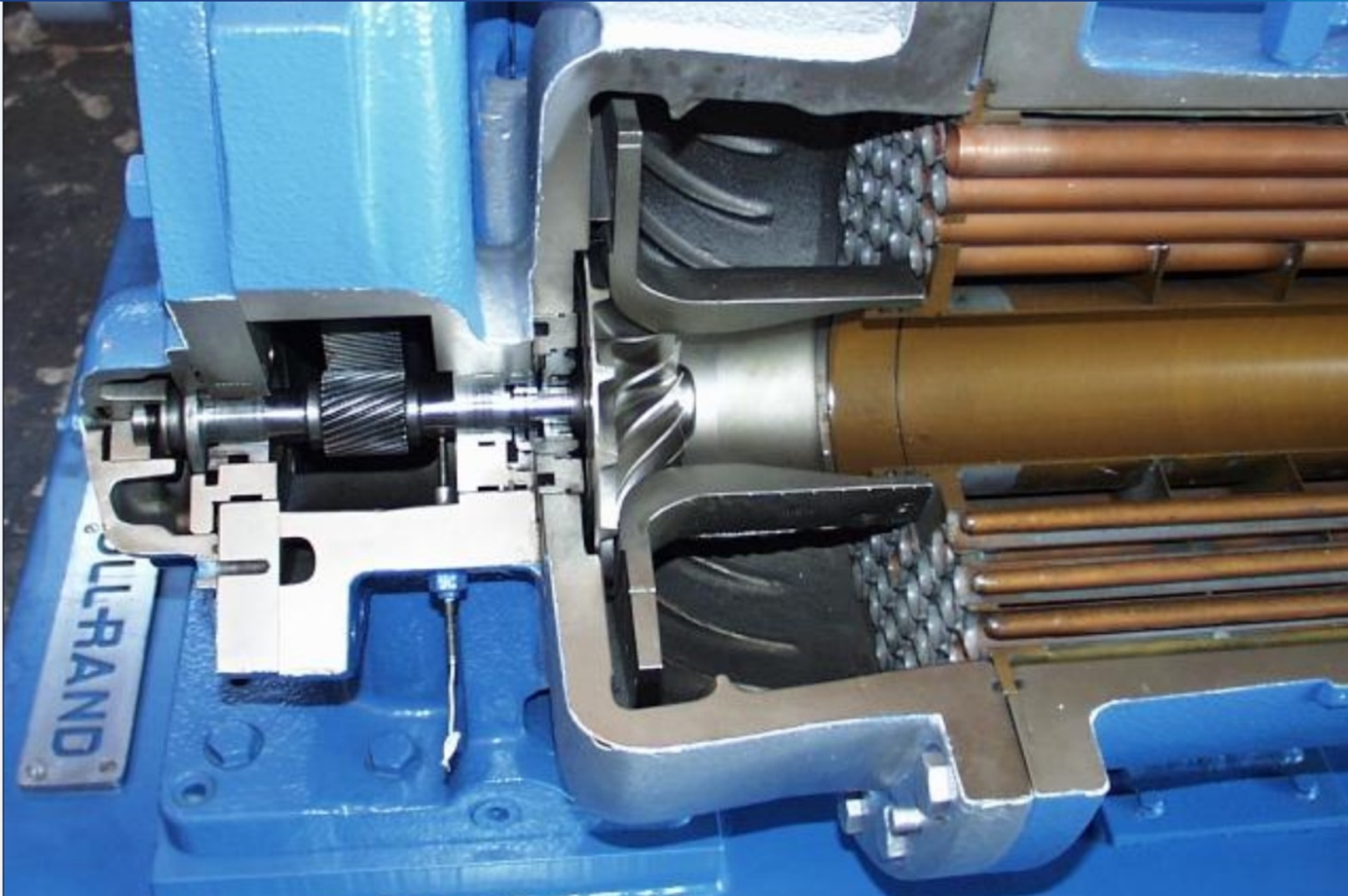

# Compressor Room Ventilation

# Ventilation

- Compressors generate heat; this heat must be removed to make sure the temperature in the compressor room is at an acceptable level. Therefore, proper ventilation is important when designing an efficient compressor room.

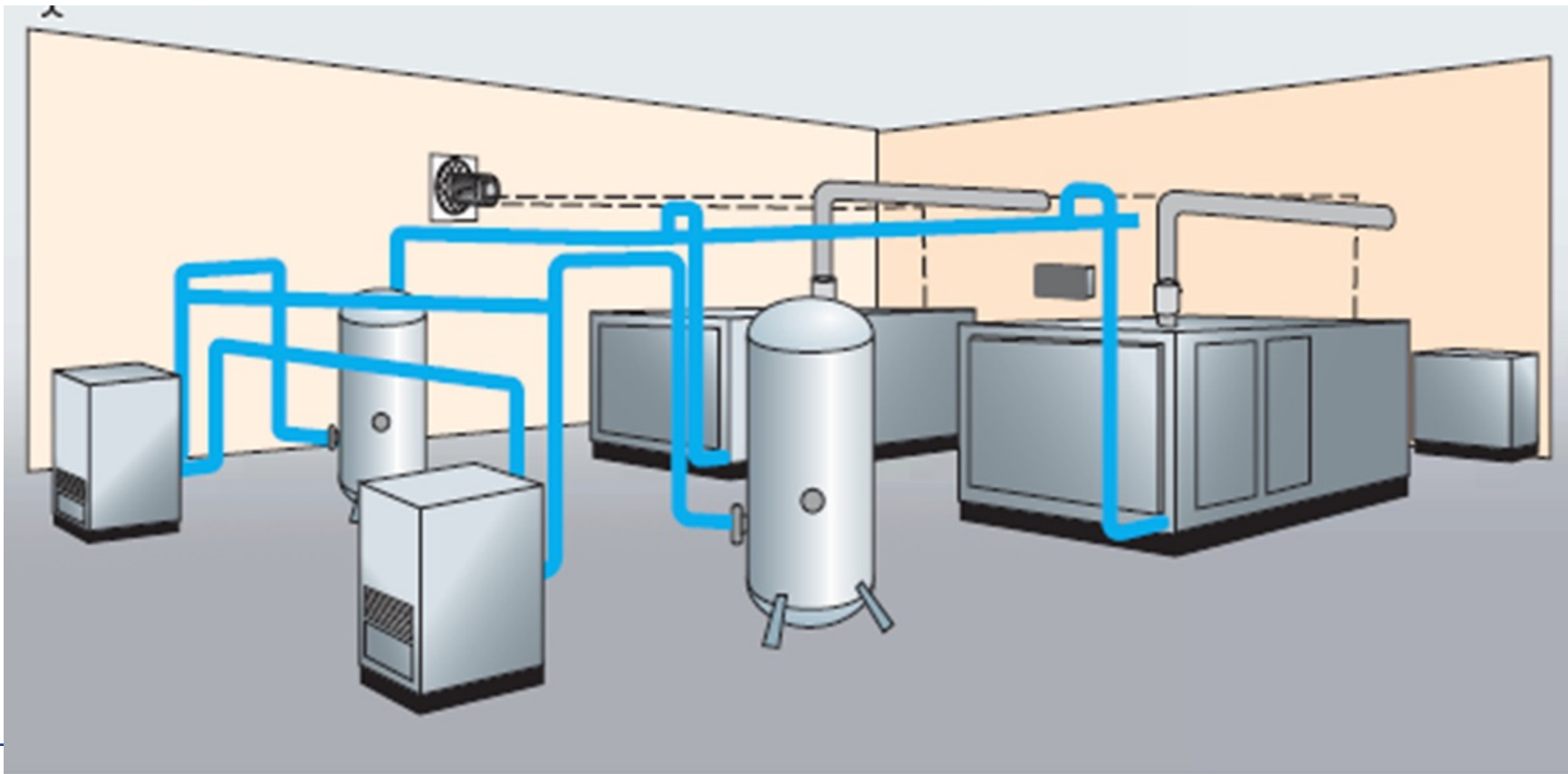

# Ventilation

- When choosing a location, it is important to find an area that provides an adequate supply of cool, clean, dry air.
- Consideration must also be given to any harmful gases that may be in the area.
- Some compressors and other critical downstream end uses will experience problems when the compressor is located where there are hydrocarbon, ammonia or chlorine vapors.
- An ambient temperature of 40 – 100°F should be maintained at all times to keep compressors running properly.
- Compressor after coolers are typically designed to cool compressed air to a temperature of “ambient +15° F.”

# Ventilation

- Conversely, if compressor room temperatures drop below freezing, condensate lines can freeze and cause ice to form in the in the after cooler, discharge line or dryer.
- As ice forms, it will expand and potentially damage any of these components.
- Cold temperatures will also increase coolant viscosity, requiring the motor to use more power to turn the airend.
- In turn, it will drive up energy and maintenance costs due to the malfunctioning of the motor and bearings.

# Ventilation

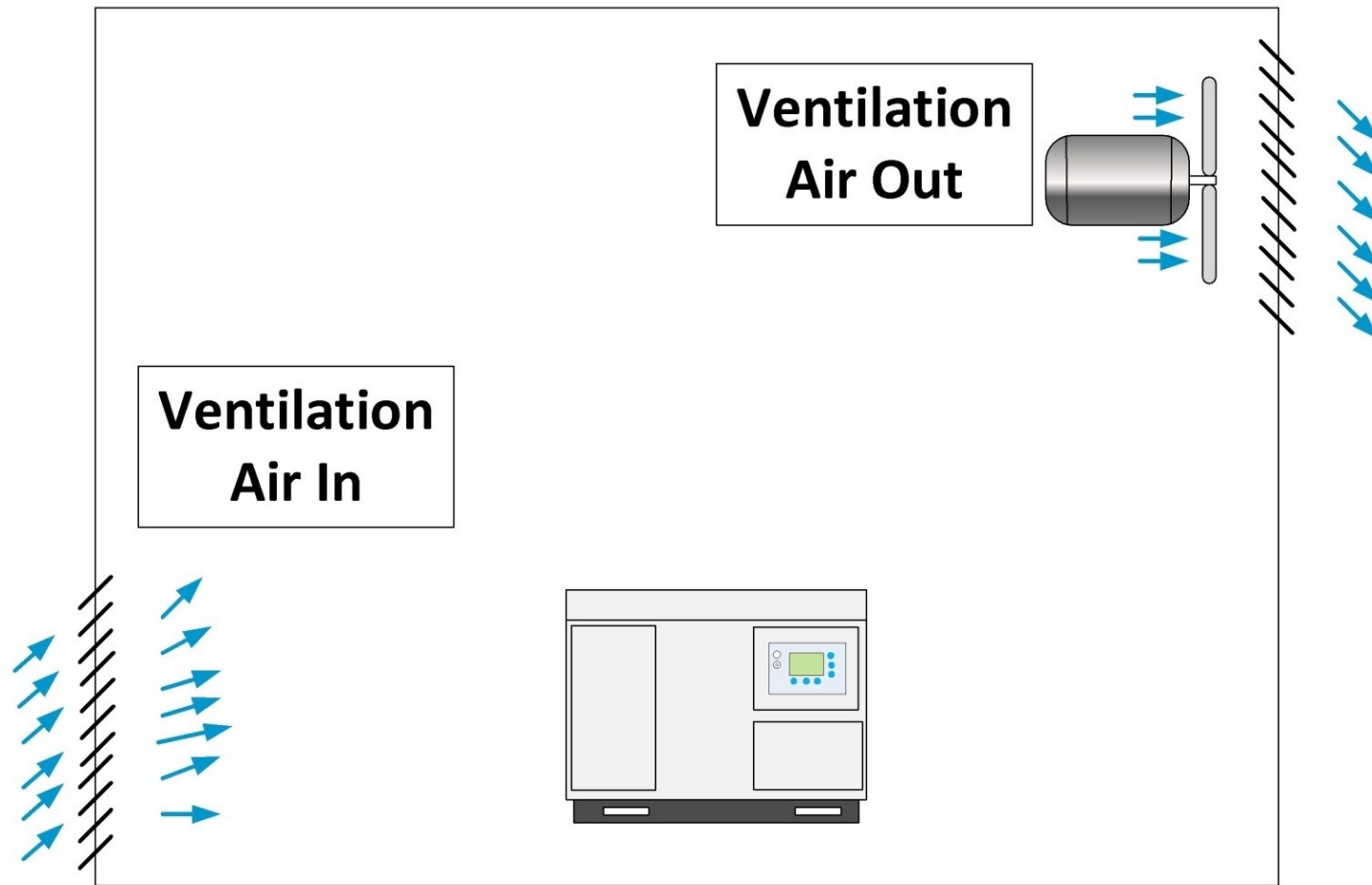



# Ventilation

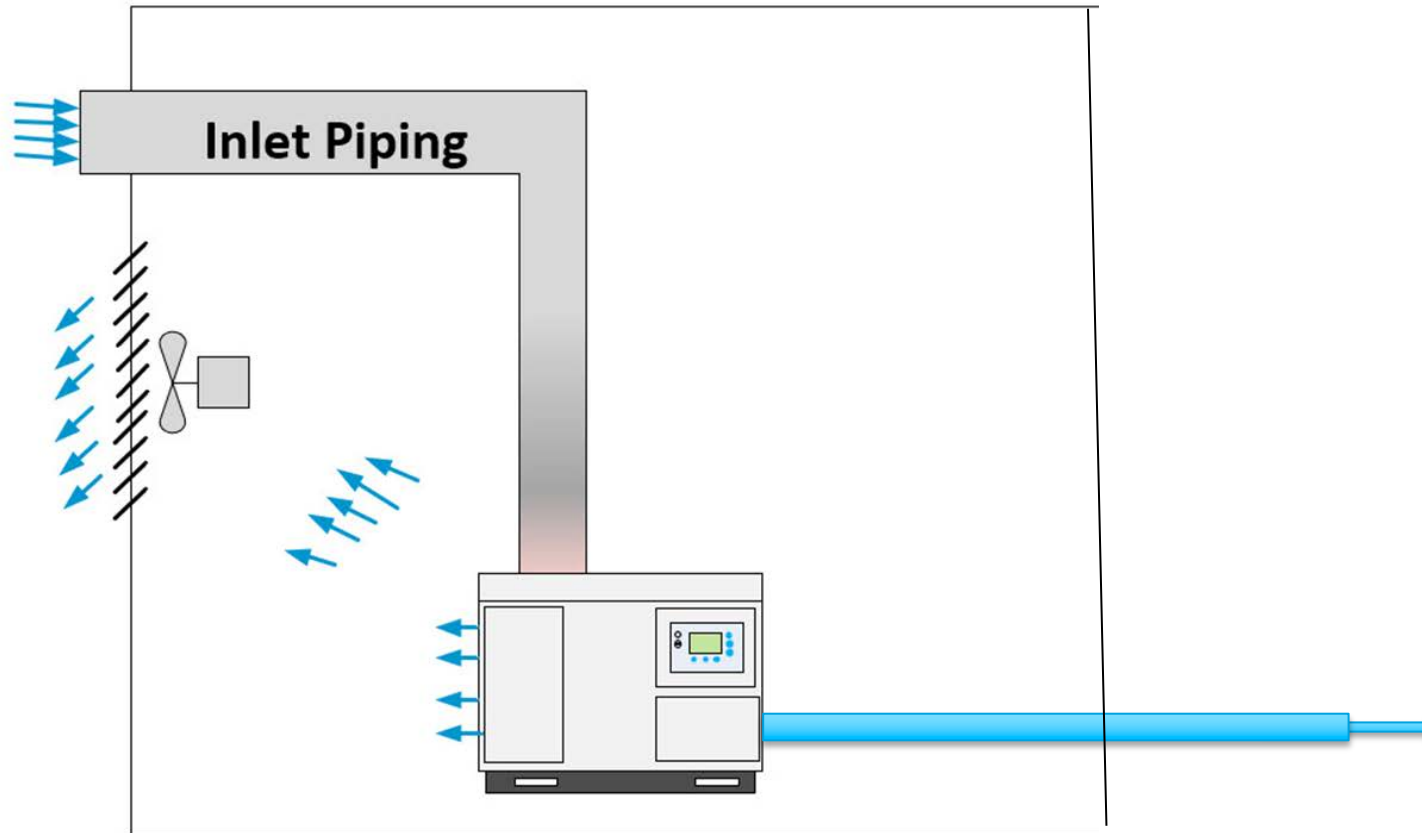

# Ducting

- If the design of the compressor room makes it too difficult for cooling air to flow across the compressor, then ducting is the best alternative.
- You have the option of ducting both the inlet and outlet air, or just one, depending on your current setup.
- Make sure to review the manufacturer's specifications on airflow and how to size your ventilation ducting in order to keep backpressure at a minimum.
- Most cooling fans are not designed to work effectively with more than 1/10 psi of backpressure. (about 3 inches water pressure)

# Examples of Mistakes in Ducting:

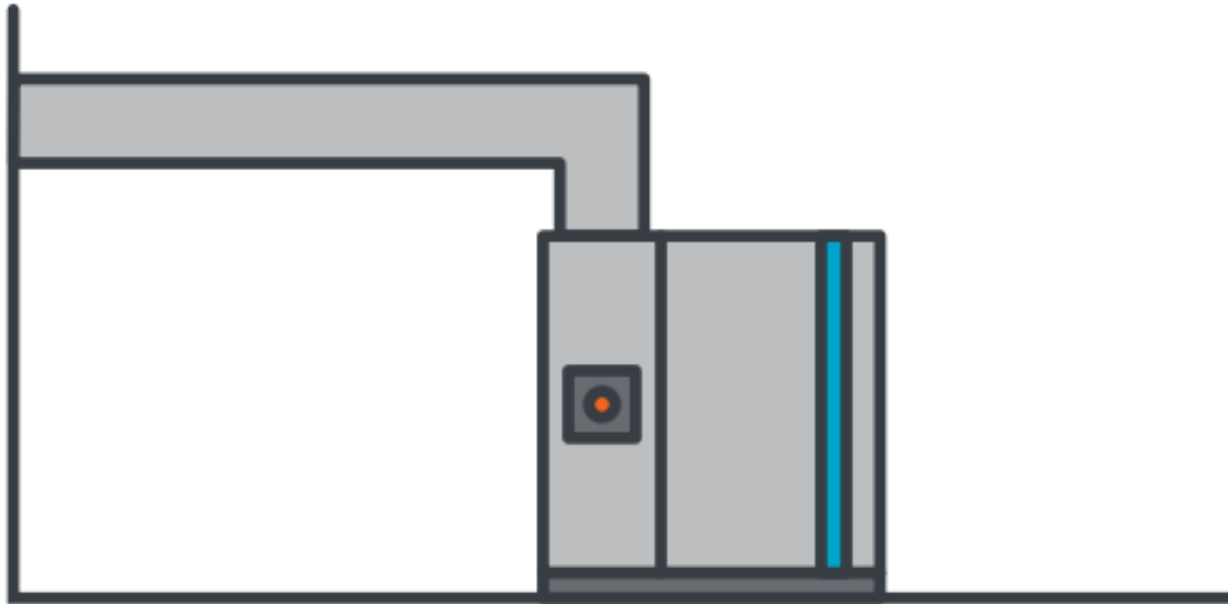

- Using rectangular bends
  - This will increase the pressure drop
  - Solution: using more rounded bends

# Examples of Mistakes in Ducting:

- Interconnecting the Ducting
  - Results in heating problems
  - Solution: installing a separate ducting for both compressors

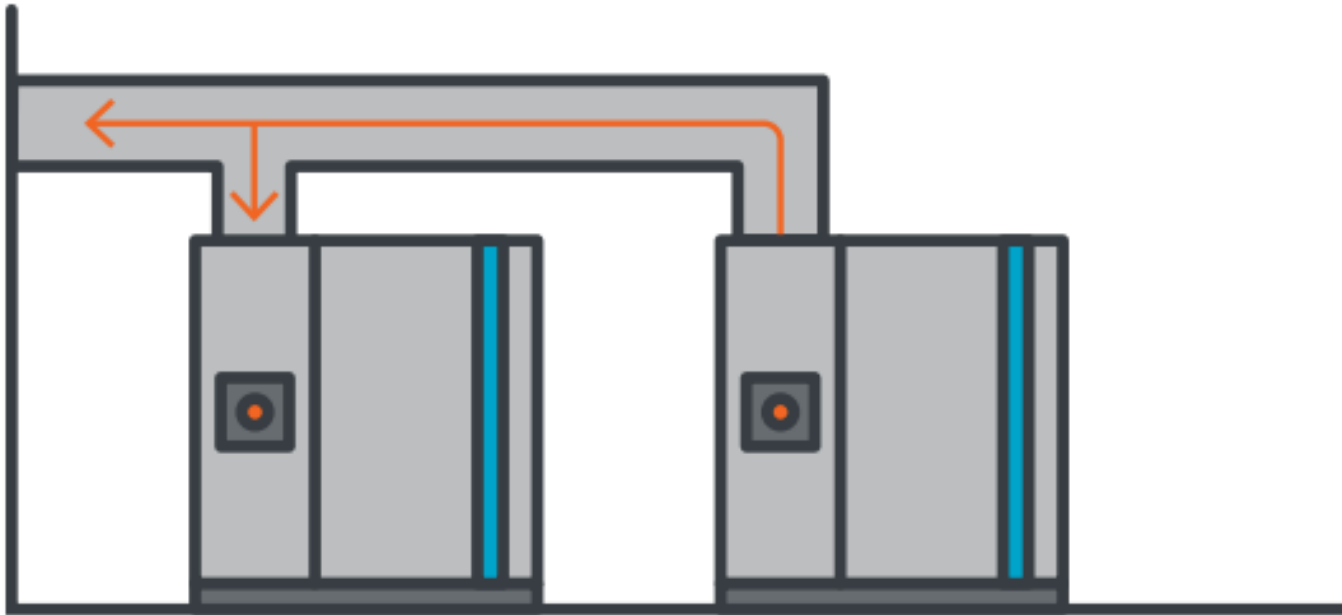

# Examples of Mistakes in Ducting:

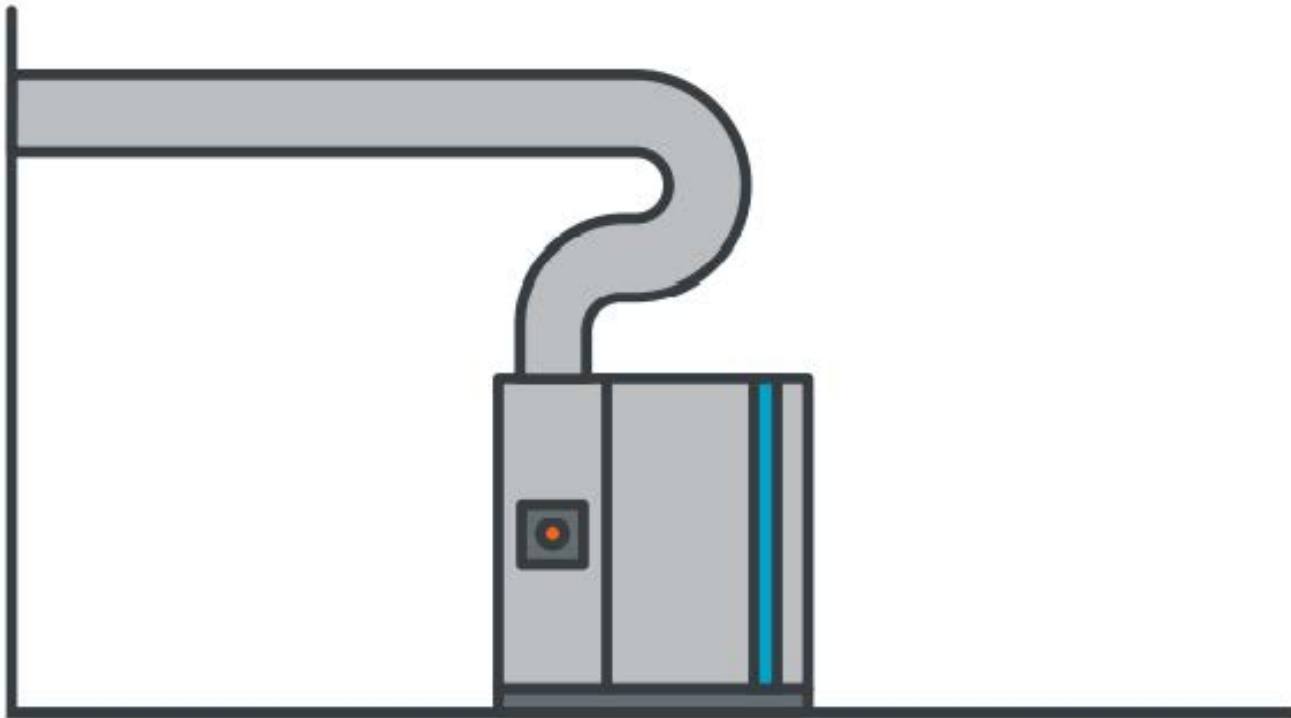

- Ducts are too long or there are too many bends
  - Will create excessive pressure drop and back pressure for aftercooler fan resulting in heating problems or shut down
  - Solution: design the duct to keep distance and bends minimal

# Examples of Mistakes in Ducting:

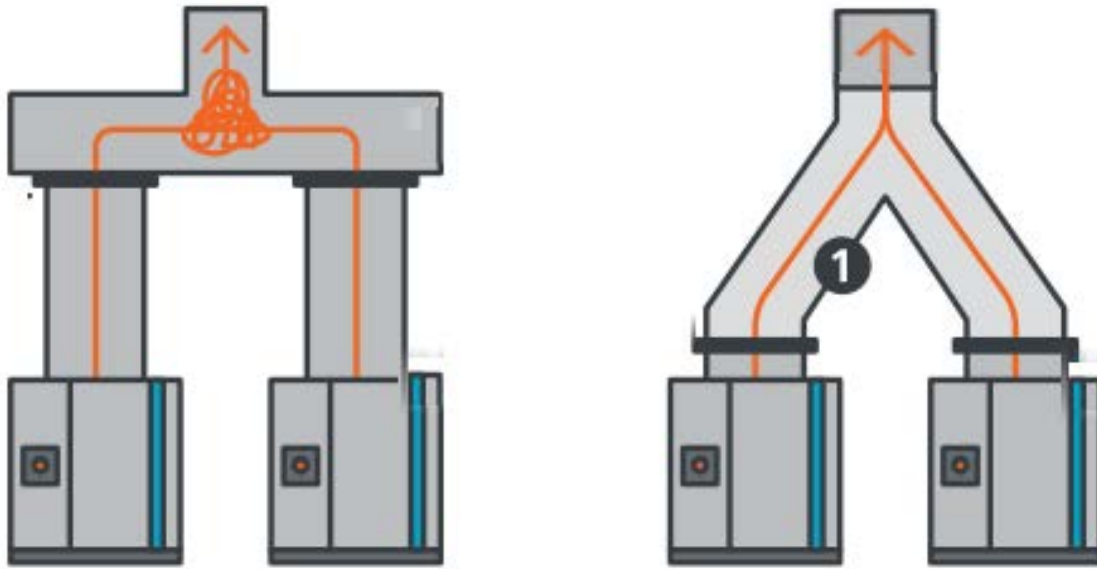

- Extra turbulence will create a higher pressure drop
  - Configuration on the left will cause possible shutdown from high temperature
  - Solution: direct the ducting as shown on the right in figure 1

# Ventilation



# Rotary Screw

- All air-cooled air compressors need to be operated in well ventilated and clean environments with fairly constant temperatures.





# Ventilation

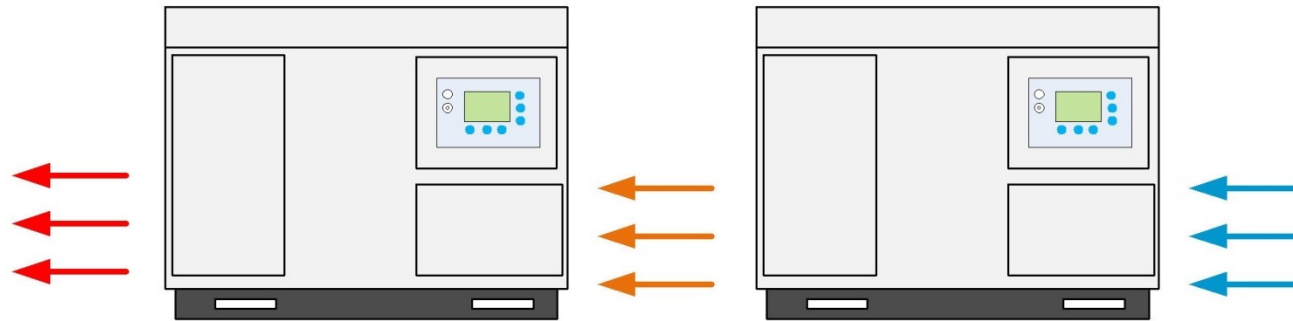

It is important not to block the air flow to the compressor inlet filter. If you have a multiple compressor installation, it is important, especially with air cooled units, that the heat discharge of one compressor does not go directly into the inlet of another compressor. This will cause shutdowns due to high temperature.

# Capturing the Heat

- **Air-cooled rotary screw compressors**
  - Adding ductwork with auxiliary fans to compressor package
  - Recover to space or reject outdoors with thermostatic controls
- **Water-cooled compressors**
  - Install heat exchangers to recover to space or reject outdoors
  - Produce non-potable (gray) or potable hot water
  - Compressors using water-cooled motors offer further opportunity (above 1000hp)
- **Engine driven compressors**
  - Heat can be recovered from engine jackets and exhaust stream

# Remember this slide from session one?

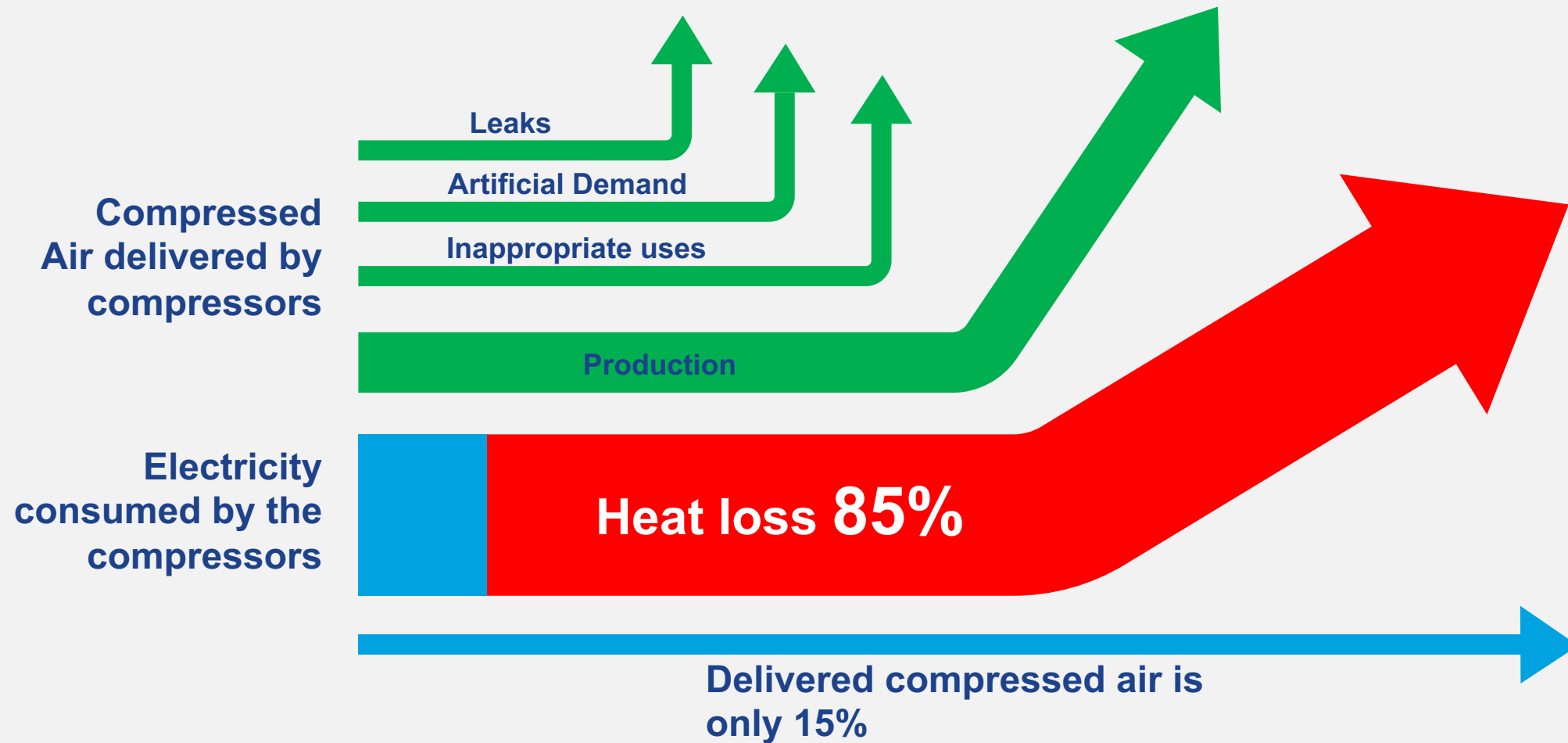

# Air Cooled Oil injected compressor

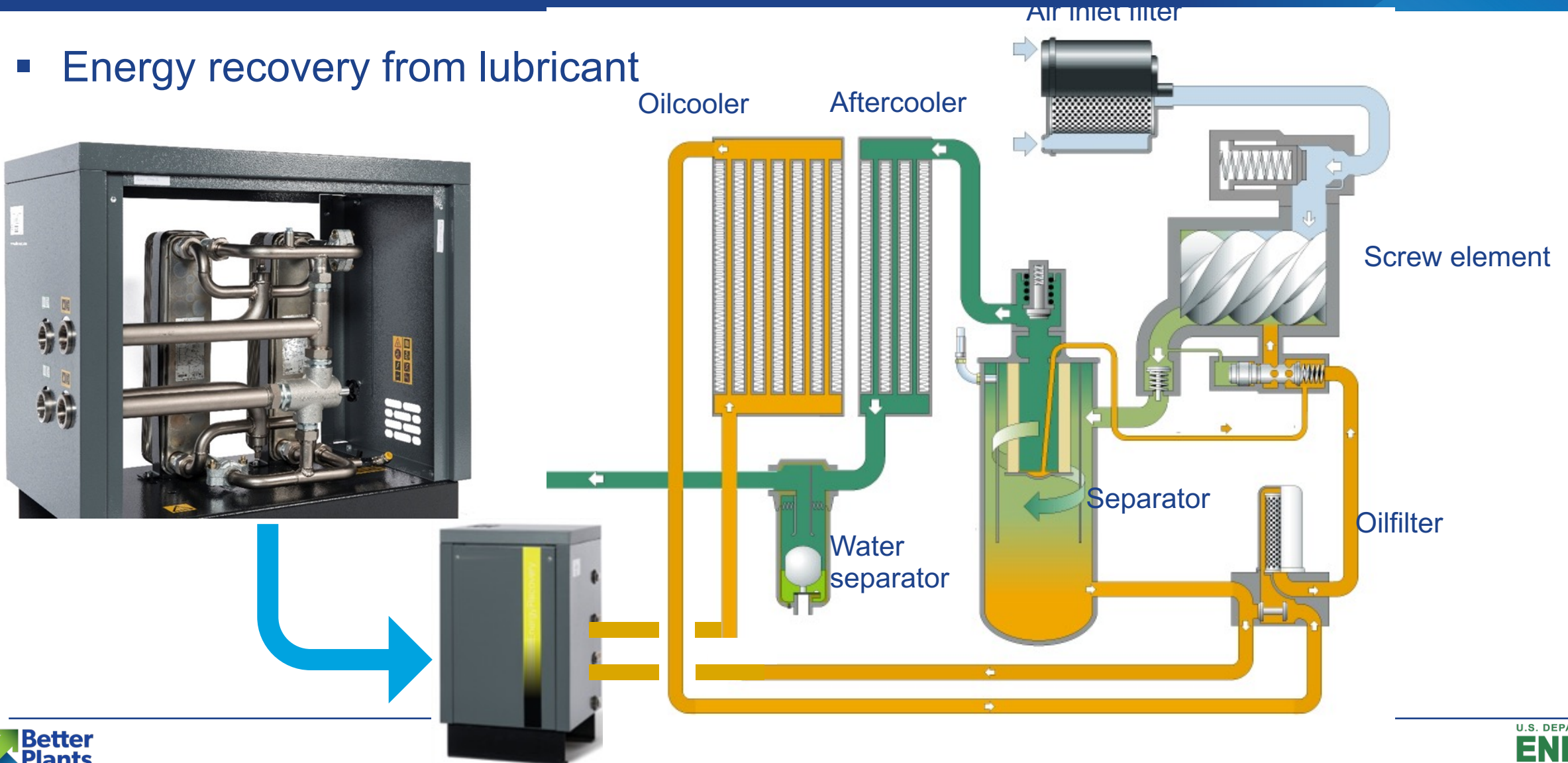

- Energy recovery from lubricant





## Summer

No heating is needed as the outside temperature already heats up the factory, all hot air is guided outside.

-  ambient air
-  heated ambient air

compressor room

factory floor

64F



office

68F





## Winter

During this time of the year, the hot air is continuously guided in to the factory, which significantly reduces the amount of money spent on heating costs.

- ambient air
- heated ambient air

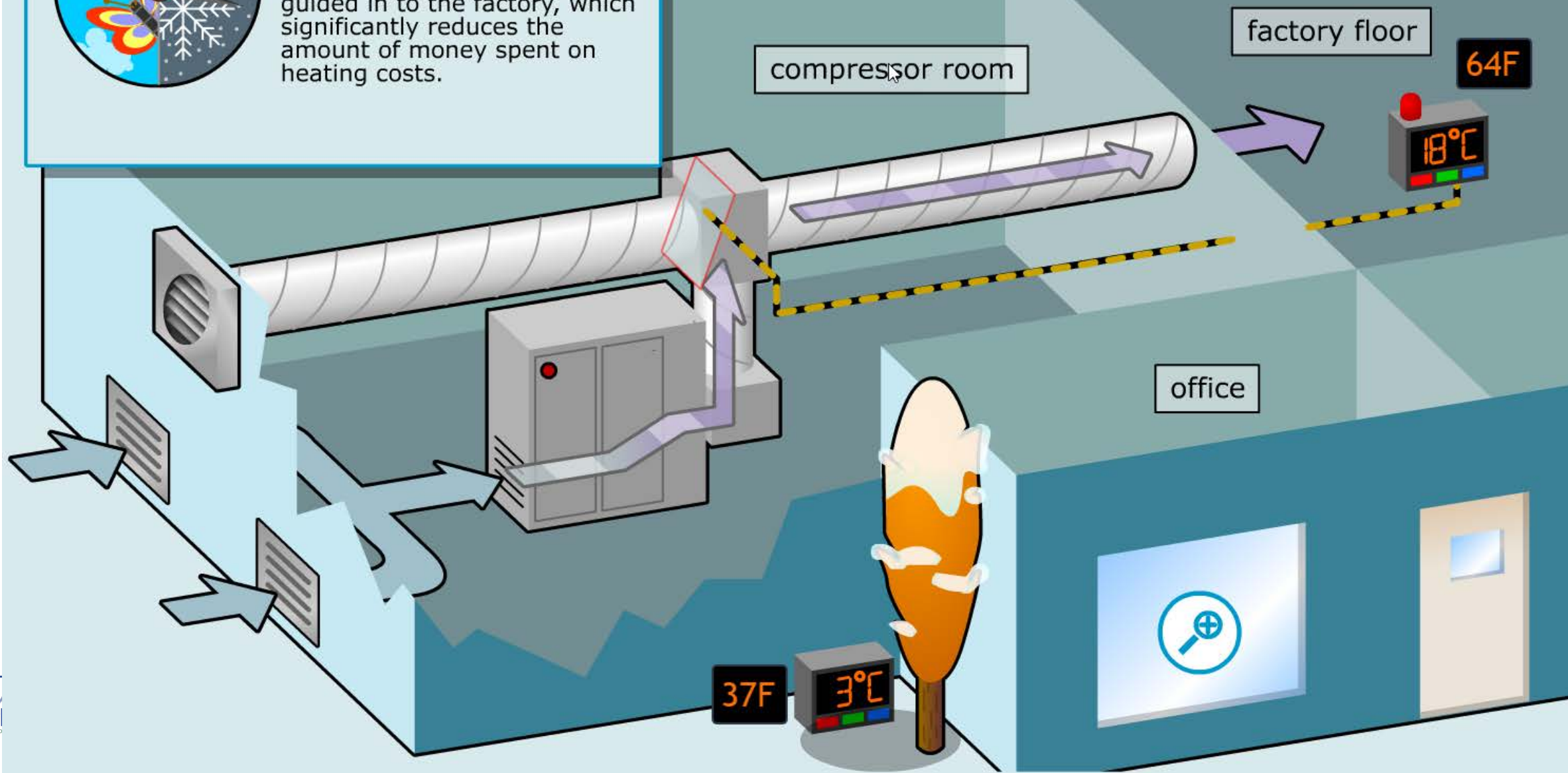

# Water Cooled Comrpressors

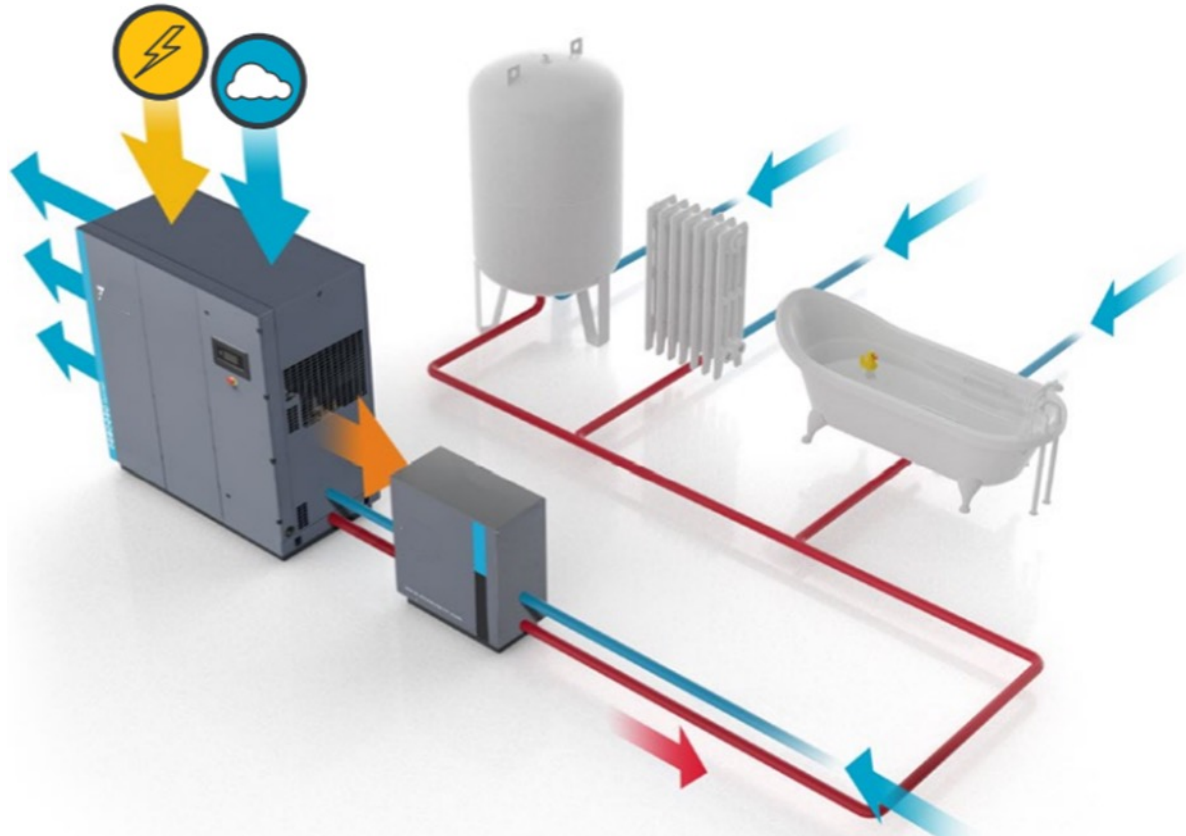

- A water-cooled compressor makes little demand on the ventilation of the compressor room.
- Most of the produced heat is absorbed by the cooling water
- The cooling water from a water-cooled compressor contains 90% of the heat energy

# Oil Free Compressor Heat Capture

**100%**  
Electrical energy input

**5%-20%**  
Condensation heat in  
suction air

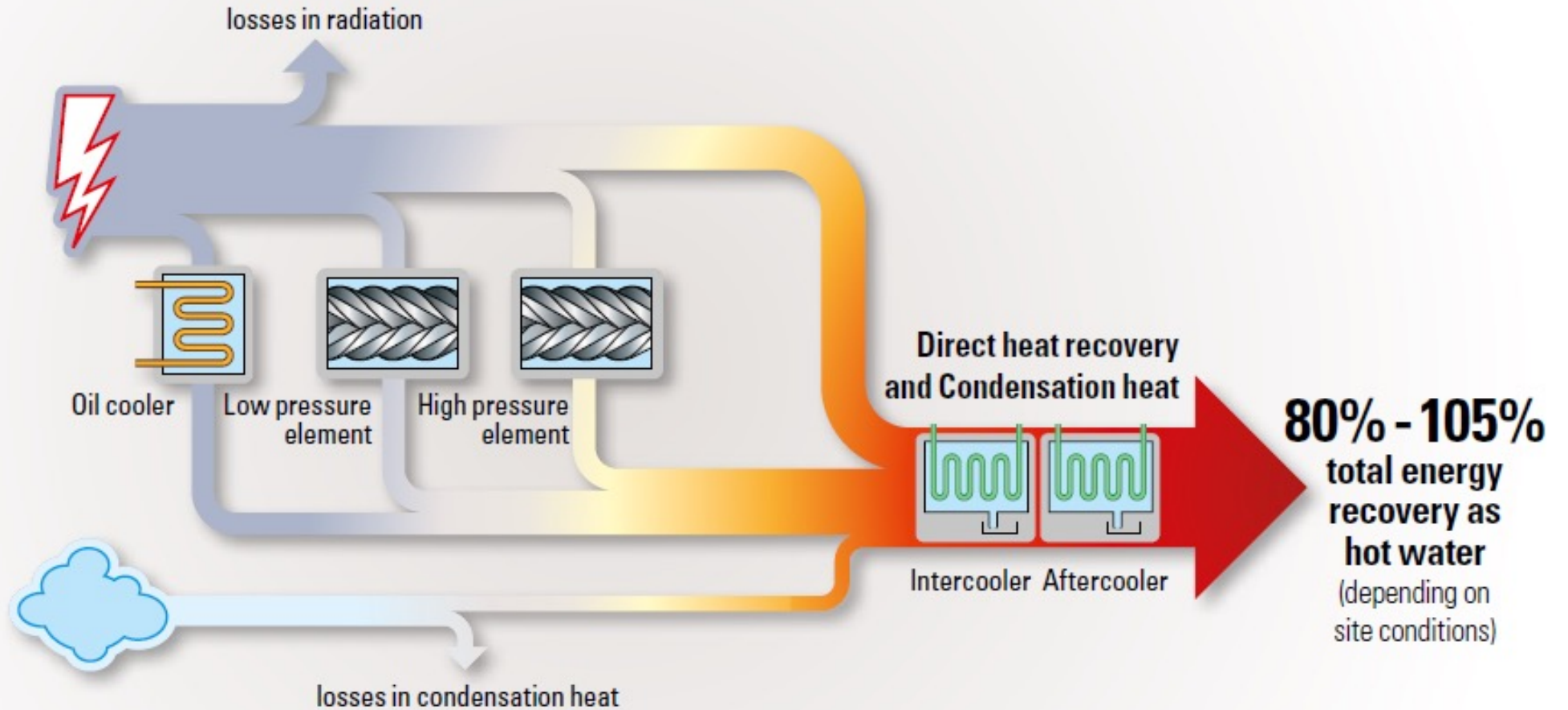



# Ventilation Equation Derived:

- Exhaust ventilation can be used to remove excess heat and/or humidity if a replacement source of cooler air is available.
- To determine the required general ventilation, one must estimate the acceptable temperature or humidity rise.
- The first step in determining the required volumetric flow is to determine the sensible and latent heat load.
- Next, determine the volumetric flow to dissipate the sensible heat and the volumetric flow to dissipate the latent heat.
- The required general ventilation is the larger of the two volumetric flows.
- Since the sensible heat is always the larger value in a compressor room, we will only work with this equation.

# Ventilation Equation Derived:

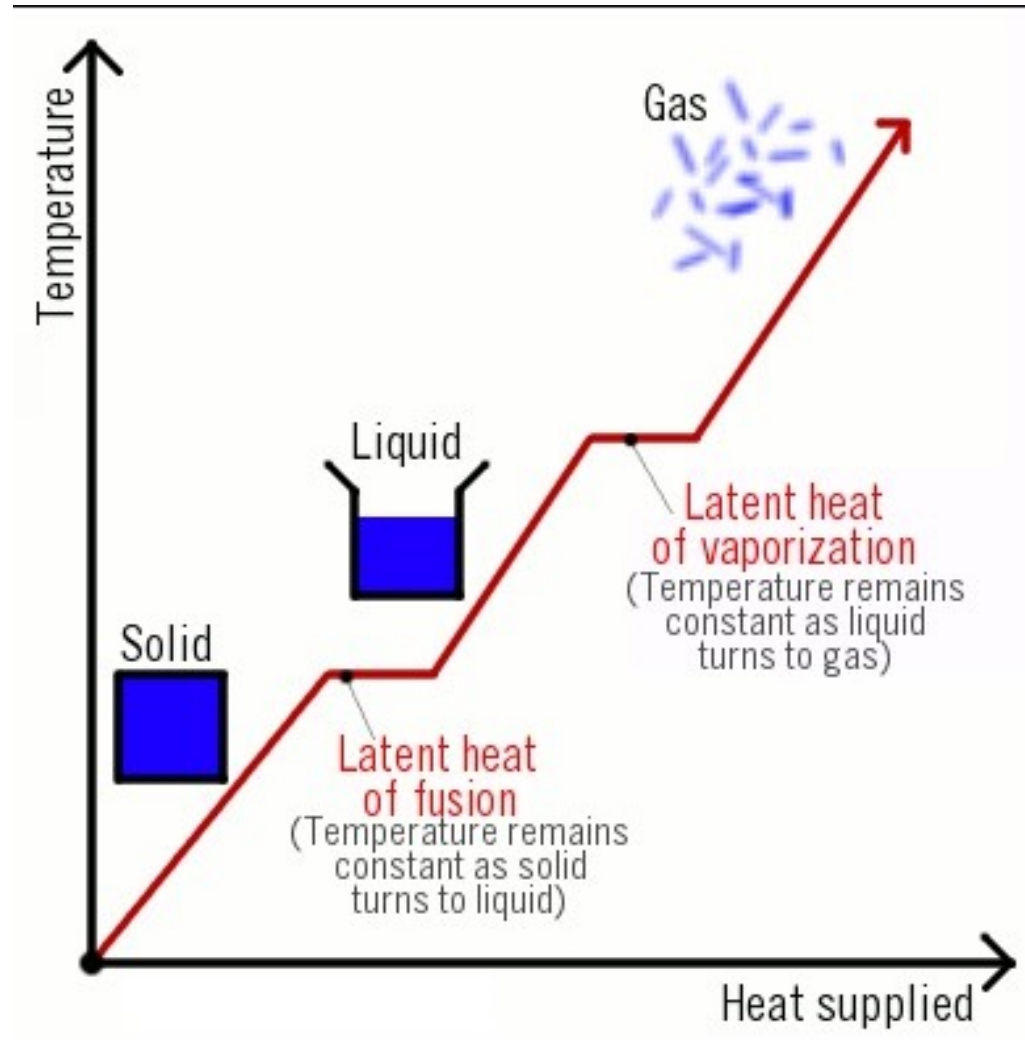

- **Sensible heat** is literally the heat that can be felt. It is the energy moving from one system to another that changes the temperature rather than changing its phase.

# Ventilation Equation Derived:

- The sensible heat rise can be determined by the following:

$$H_s = Q_s \times \rho \times C_p \times \Delta T \times 60_{m/hr}$$

Where:

- $H_s$  = sensible heat gain, BTUs per hour
- $Q_s$  = volumetric flow for sensible heat, CFM
- $\rho$  = density of air, lb/ft<sup>3</sup>
- $C_p$  = specific heat of the air, BTU/lb-deg F
- $\Delta T$  = change in temperature, degrees Fahrenheit
- For air  $C_p = 0.24$  BTU/lb-deg F and  $\rho = 0.075$  lb/ft<sup>3</sup>;

It takes 0.24 BTU of heat to change the temperature of one pound of air by one degree F.

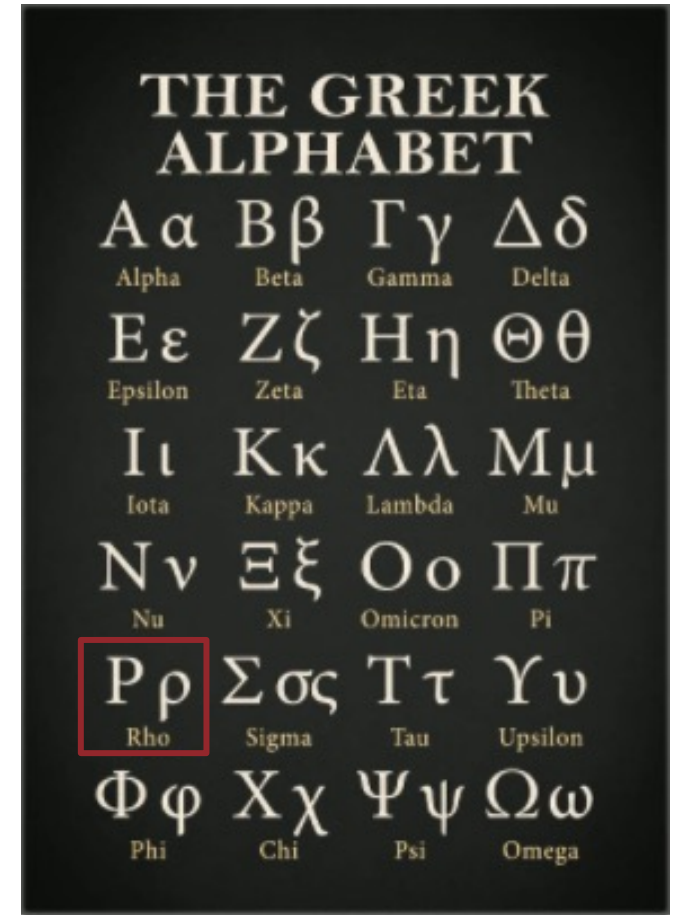

# Ventilation Equation Derived:

Consequently, the equation becomes:

$$H_s = Q_s \times 0.075 \text{ lb/cf} \times .24 \text{ BTU/lb-deg} \times \Delta T \times 60 \text{ m/hr}$$

Or

$$H_s = Q_s \times 1.08 \times \Delta T$$

$$Q_s = \frac{H_s}{(1.08 \times \Delta T)}$$

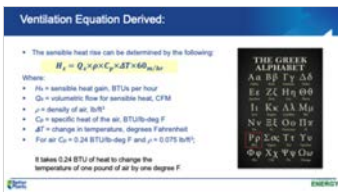

Ventilation Equation Derived:

- The sensible heat rise can be determined by the following:  
 $H_s = Q_s \times \rho \times C_p \times \Delta T \times 60 \text{ m/hr}$

Where:

- $H_s$  = sensible heat gain, BTUs per hour
- $Q_s$  = volumetric flow for sensible heat, CFM
- $\rho$  = density of air, lb/ft<sup>3</sup>
- $C_p$  = specific heat of the air, BTU/lb-deg F
- $\Delta T$  = change in temperature, degrees Fahrenheit
- For air  $C_p = 0.24$  BTU/lb-deg F and  $\rho = 0.075$  lb/ft<sup>3</sup>
- It takes 0.24 BTU of heat to change the temperature of one pound of air by one degree F

THE GREEK ALPHABET  
Α Β Γ Δ Ε Ζ Η Θ Ι Κ Λ Μ Ν Ξ Ο Π Ρ Σ Τ Υ Φ Ψ Ω  
Α Β Γ Δ Ε Ζ Η Θ Ι Κ Λ Μ Ν Ξ Ο Π Ρ Σ Τ Υ Φ Ψ Ω

- In order to use this equation, it is necessary to first estimate the heat load.
- This will include sunshine, people, lights, and motors as well as other particular sources of heat.
- Of these sunshine light and motors are all completely sensible heat.
- The people heat load is part sensible and part latent and can be ignored in a compressor room situation.
- In using the sensible heat equation, one must decide the amount of temperature rise that will be permitted.
- A 10° rise is very common for a compressor room environment.

# Exhaust Size Fan Ventilation Simplified Equation

- The following formula can be used to determine the fan size needed to vent a compressor room given a certain horsepower online and venting into the room:

$$\text{Fan cfm} = \frac{\text{Heatload (BTU / Hr)}}{1.08 \times \text{Temp Rise (deg F)}}$$

- 1 HP = 2,545 BTU / hr
- The heat load is sensible duty only.
- Temp rise is above make-up air temp.
  - A 10-degree rise is all you really need.

# Ventilation Example 100 HP Compressor

$$\text{Fan cfm} = \frac{\text{Heatload}(\text{BTU} / \text{Hr})}{1.08 \times \text{Temp Rise}(\text{deg } F)}$$

$$\text{Fan cfm} = \frac{(100 \times 2,545 \text{ BTU} / \text{Hr}) (\text{BTU} / \text{Hr})}{1.08 \times 10}$$

$$\text{Fan cfm} = 23,564$$

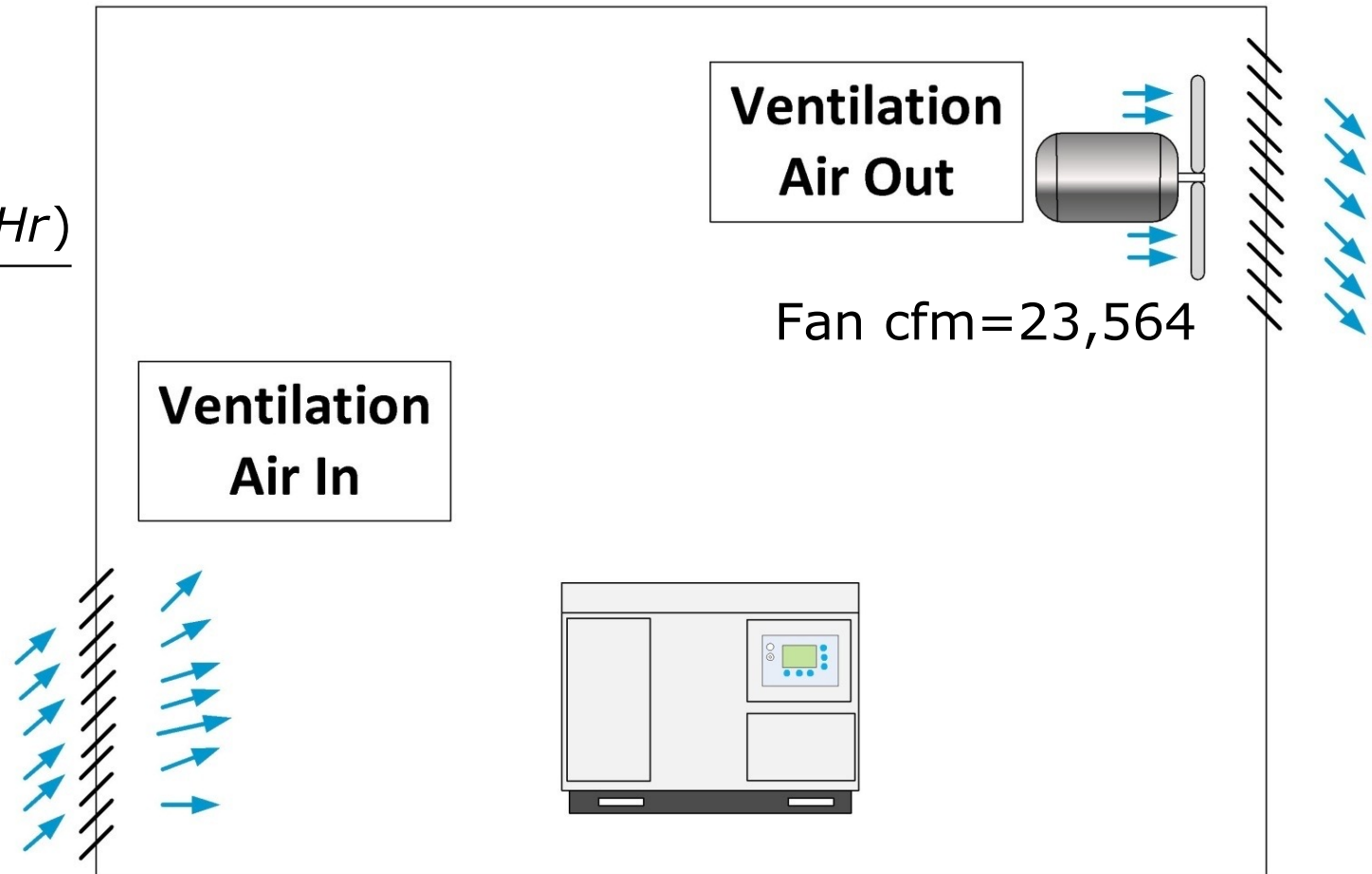

# Water Cooled Comrpressors

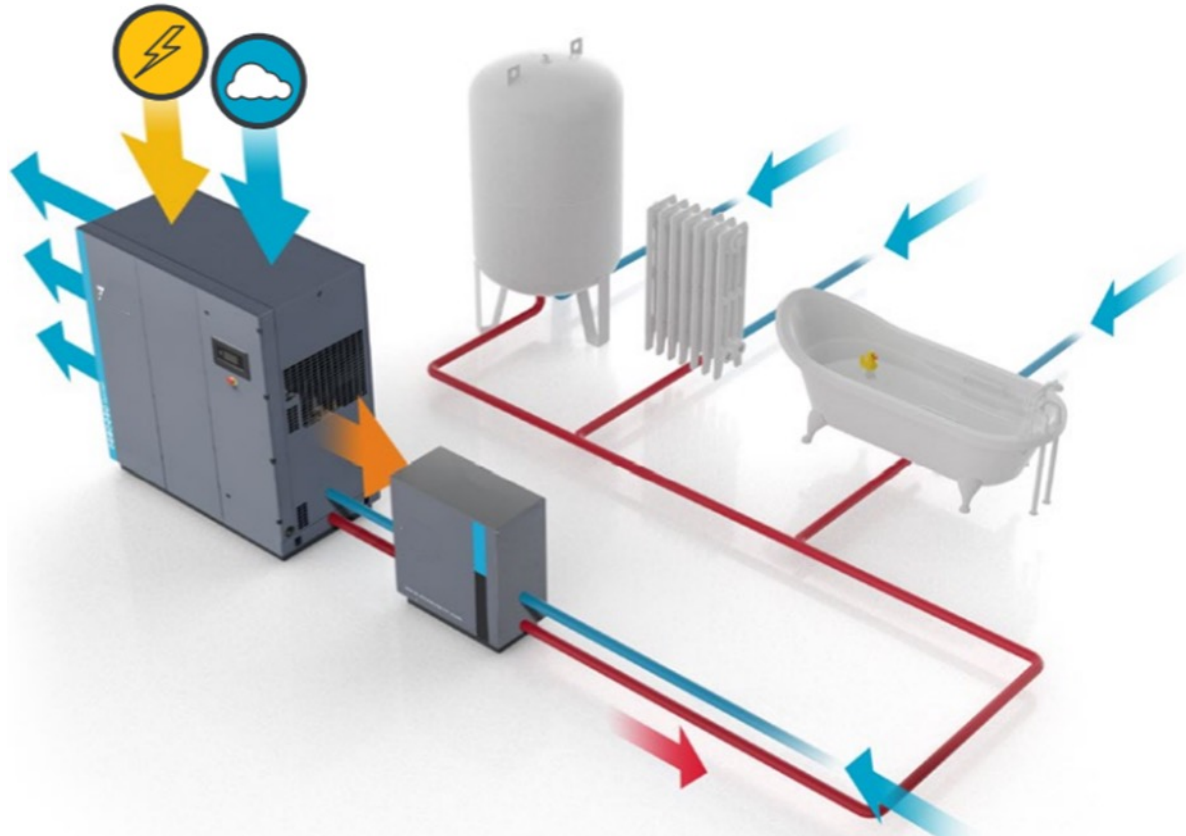

- A water-cooled compressor makes little demand on the ventilation of the compressor room.
- Most of the produced heat is absorbed by the cooling water
- The cooling water from a water-cooled compressor contains 90% of the heat energy

# 180°F COMPRESSOR DISCHARGE TEMPERATURE

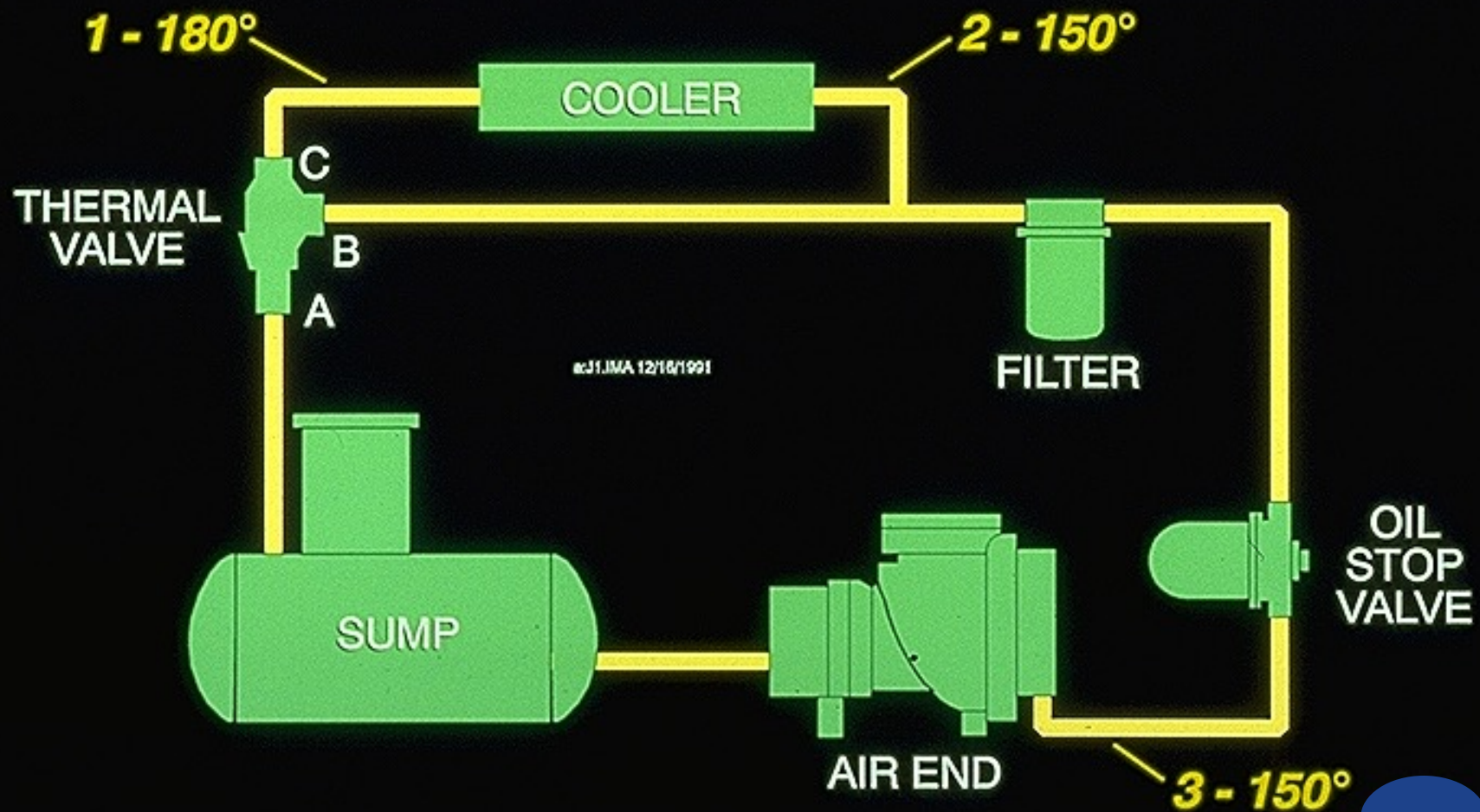



# 210°F COMPRESSOR DISCHARGE TEMPERATURE

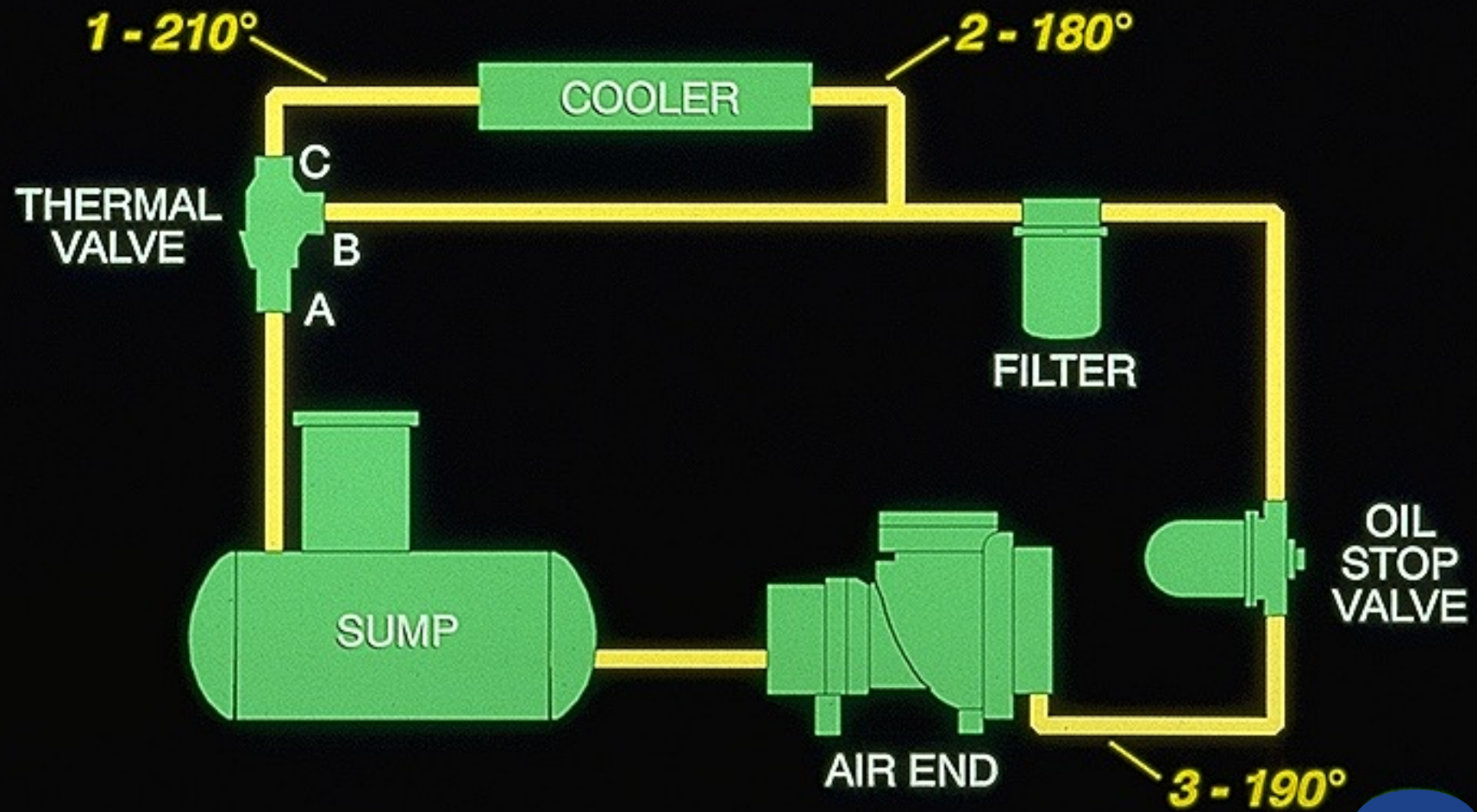

# 210°F COMPRESSOR DISCHARGE TEMPERATURE

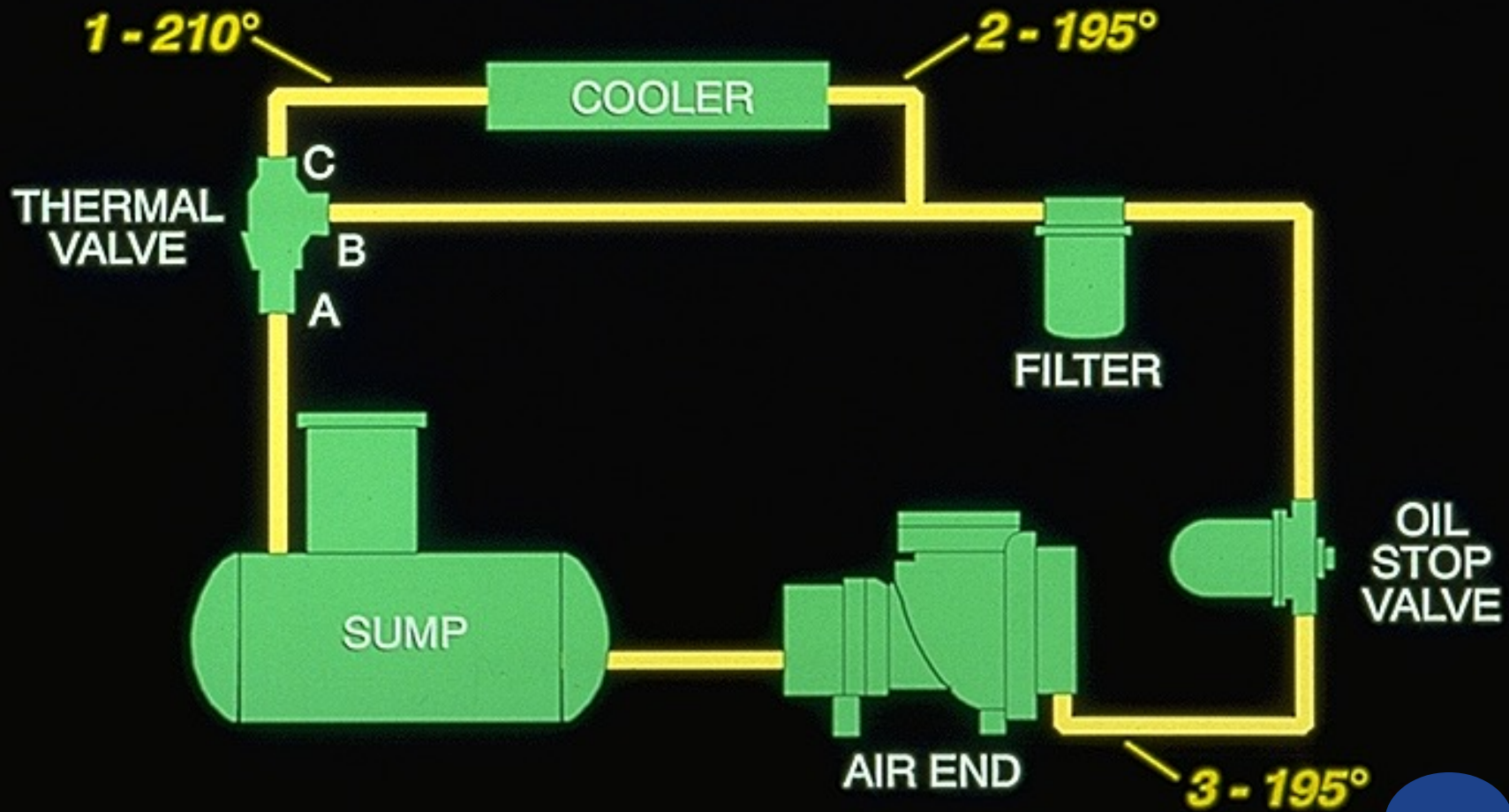

# 210°F COMPRESSOR DISCHARGE TEMPERATURE

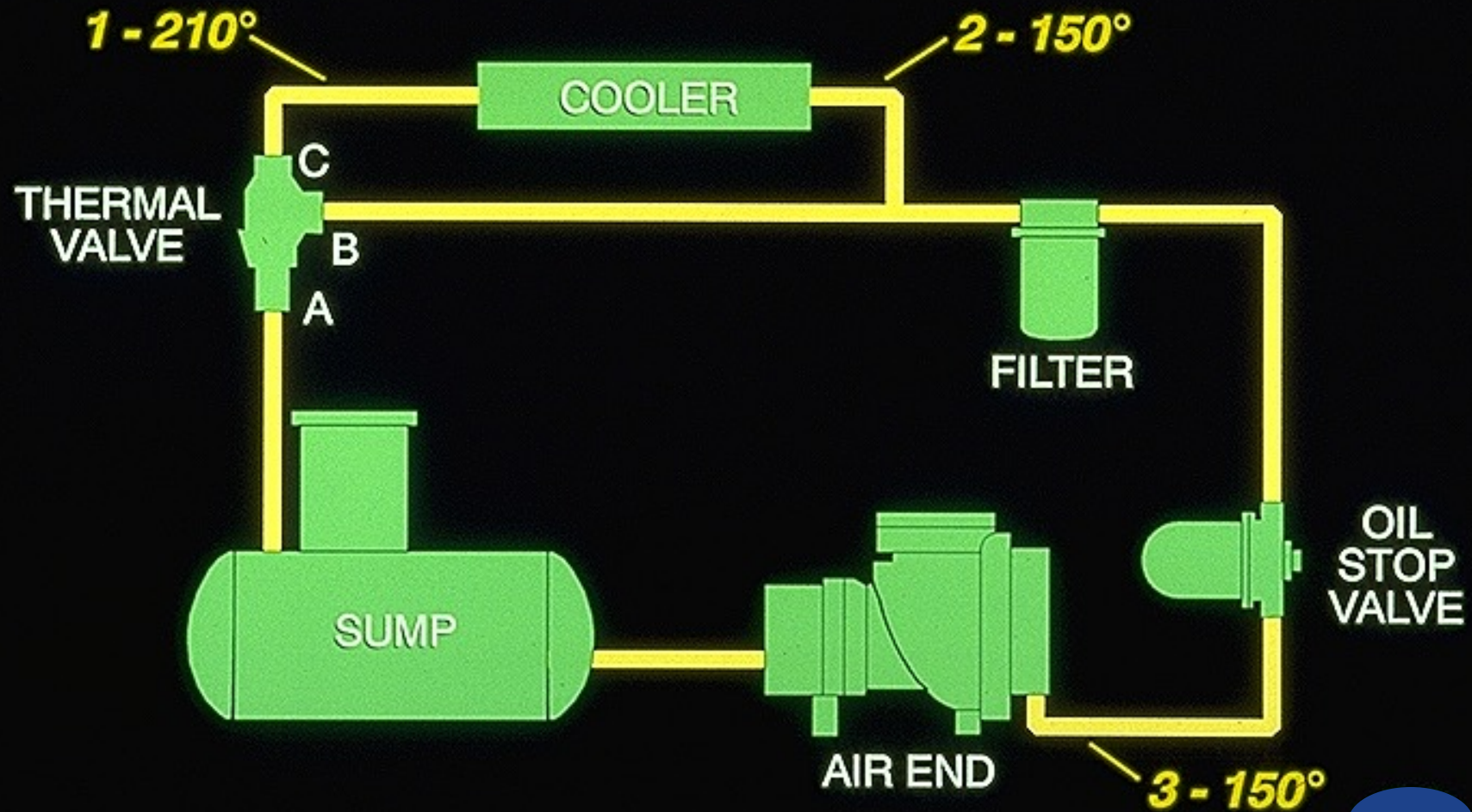

# Compressed Air Maintenance

# A Maintenance Case Study

- Compressors tripping from high temperature at full load forced the company to run extra compressors to “share” the load.
- Six compressors part loaded at 60% capacity, 91% power
- Remedy: Clean coolers, address water quality
- Results: Two compressors shut down, savings = \$103,000 annually

# Six Common Maintenance Mistakes

1. Not performing leak management
2. Not maintaining filters, end-use filters, and lubricators
3. Ignoring air dryer and condensate trap maintenance
4. Poor ventilation
5. Not taking temperature measurements
6. Not performing lubricant analysis

# 1. Not Performing Leak Management

- Leaks can make up 20-30% of total system demand
- Proactive leak maintenance programs target 5%
- In addition to wasting energy leaks also:
  - Cause a drop in pressure causing end uses to function less effectively, adversely affecting production
  - Leaks shorten the effective life of all system equipment
  - Leaks can lead to adding unnecessary compressor capacity

## 2. Filters, End-Use Filters and Lubricators

- Clogged filters cause pressure drop reducing effectiveness at end-use or additional energy at the compressor(s)
- Filter only to the level required for each point of use
- Use low pressure drop, long-life filters
- Understand flow characteristics of devices, prevent re-entrainment
- Replace elements when the cost of their pressure drop exceeds the cost of a replacement element
- Point of use filters, regulators and lubricators:
  - Provide tools with clean, stable lubricated air supply
  - Can cause tools to wear prematurely if not maintained



# 3. Dryers and Condensate Traps

- Liquid water is a natural byproduct of the compression process
- Poorly maintained dryers cause quality problems for end uses
- Moisture in compressed air is responsible for costly problems such as:
  - Rusting and scaling in pipelines
  - Clogging of instruments
  - Sticking of control valves
  - Freezing of outdoor lines
  - Product spoilage
- Condensate traps stuck in the closed position can cause quality problems
- Condensate traps stuck in the open position (or bypass valves left open intentionally) waste energy

# Is the condensate drain even working?



# Condensate removal without the loss of compressed air



# Condensate removal without the loss of compressed air

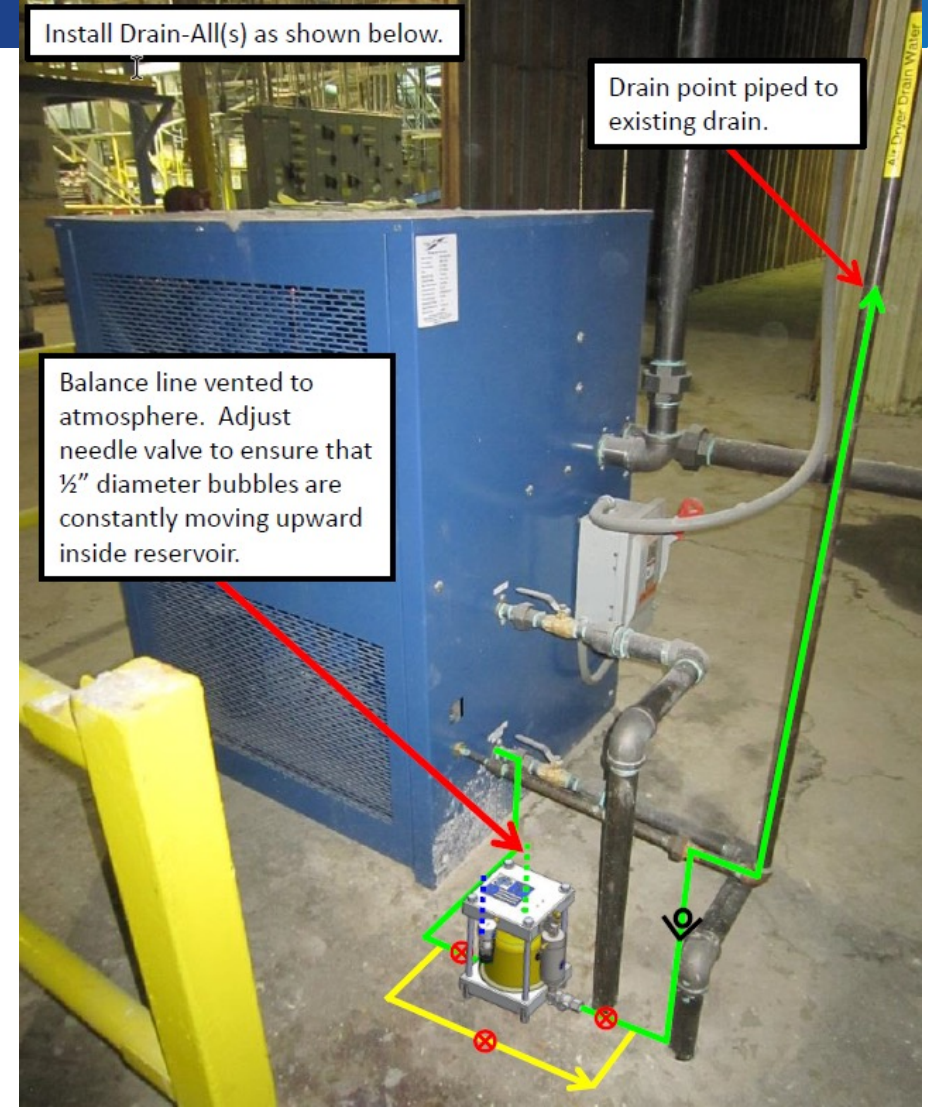
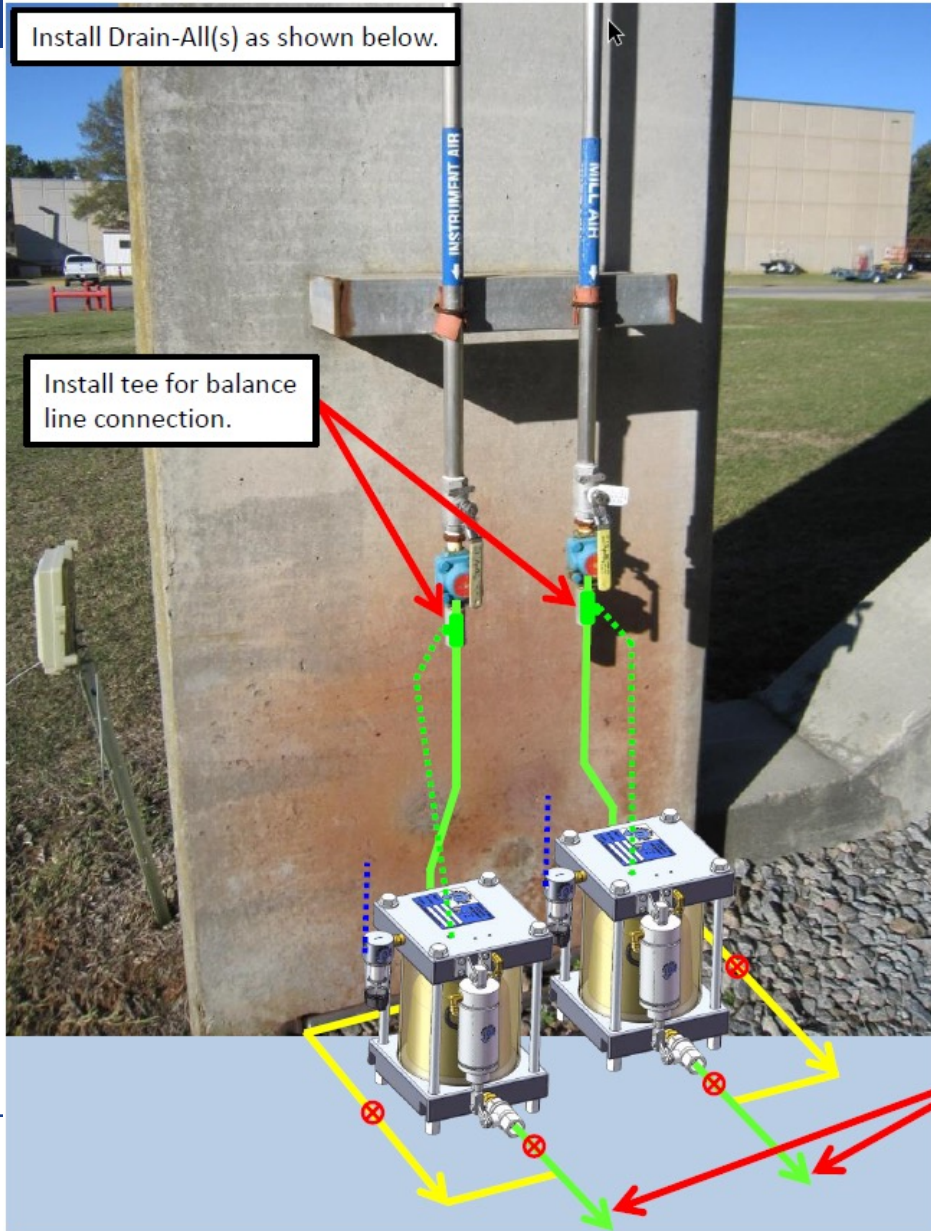

## 4. Poor Ventilation

- Heat is a common cause of unscheduled shutdowns
- Compressed air systems require extensive ventilation whether they are air cooled or water cooled
- Good planning is required to ensure effective ventilation
  - Avoid recirculating heated ventilation air
  - Allow for adequate clearance for access to the package
  - Avoid areas that are extremely humid or where temperatures exceed the capabilities of system components
- Addressing these issues reduces required maintenance of lubricant, heat exchangers, bearings and hoses
- Proper ventilation reduces energy costs





# 5. Not Taking Temperature Measurements

- Temperature is an indicator of how systems are performing
- The following measurements are important:
  - Air Intake Temperature
  - Ambient Air Temperature (cooling air)
  - Intercooler Approach Temperature (multi-stage compressors)
  - Lubricant Injected Rotary Screw Oil Temperature
  - Reciprocating Compressor Cylinder Discharge (Valve) Temperature
  - Compressor Discharge Temperature
  - Thermo-mixing Valve Temperature (Oil in, Oil out, and to sump cooler)
  - Aftercooler Outlet Temperature
  - Dryer Inlet Temperature
  - Dryer (Condenser) Ambient Temperature (air-cooled)
  - Dryer (Condenser) Water Inlet and Outlet Temperatures (water-cooled)
  - Motor Temperatures
  - Bearing Temperatures



## 6. Not Performing Lubricant Analysis

- Lubricant analysis is an indicator of compressor condition
- Key variables to watch in lubricant analysis include:
  - Particle count (ISO code)
  - Total acid number (TAN)
  - Anti-oxidant level
  - Lubricant life remaining
  - Viscosity
  - Contamination ... other lubricants
  - Water ppm



1.17.2003

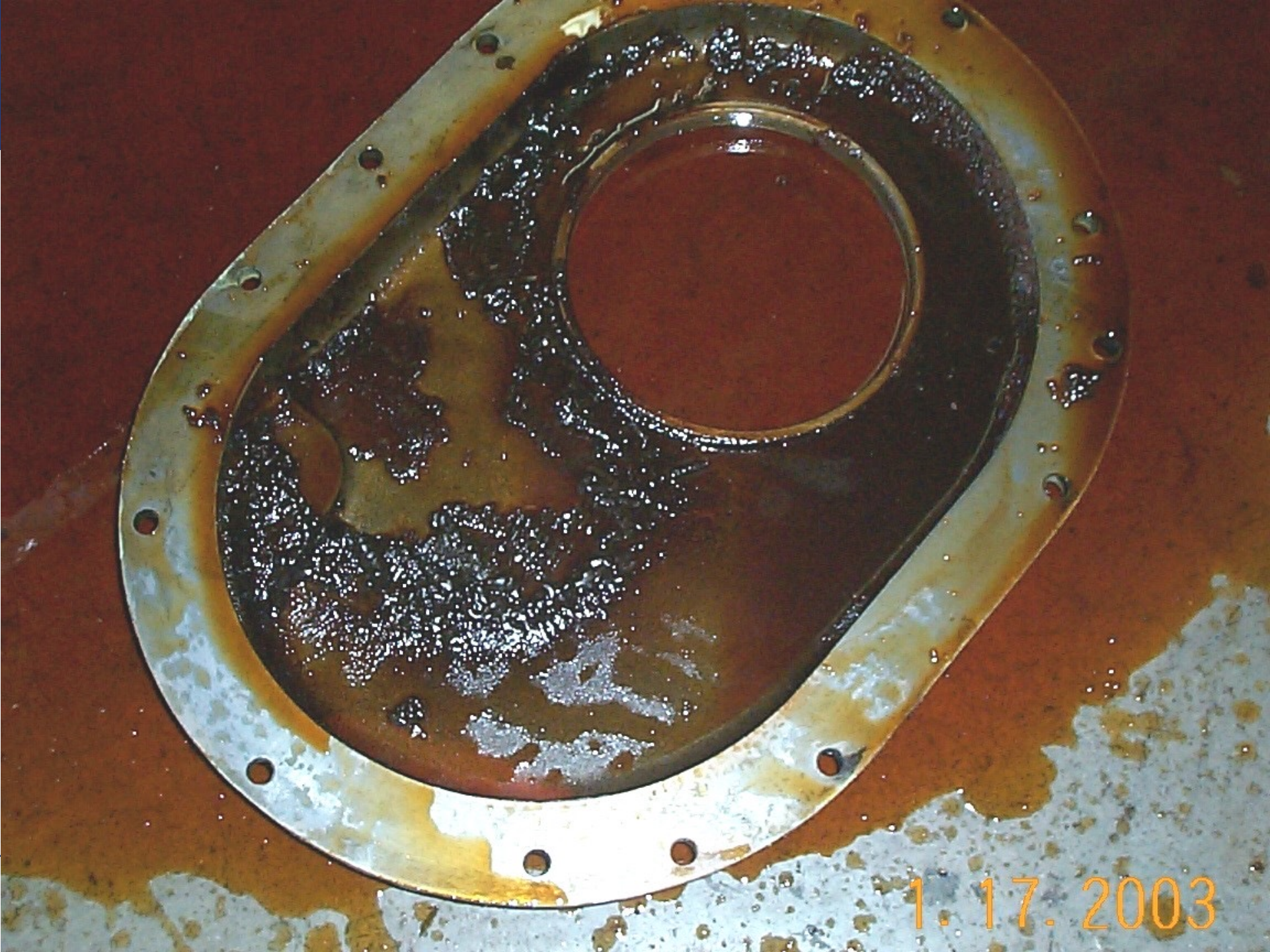

1.17.2003

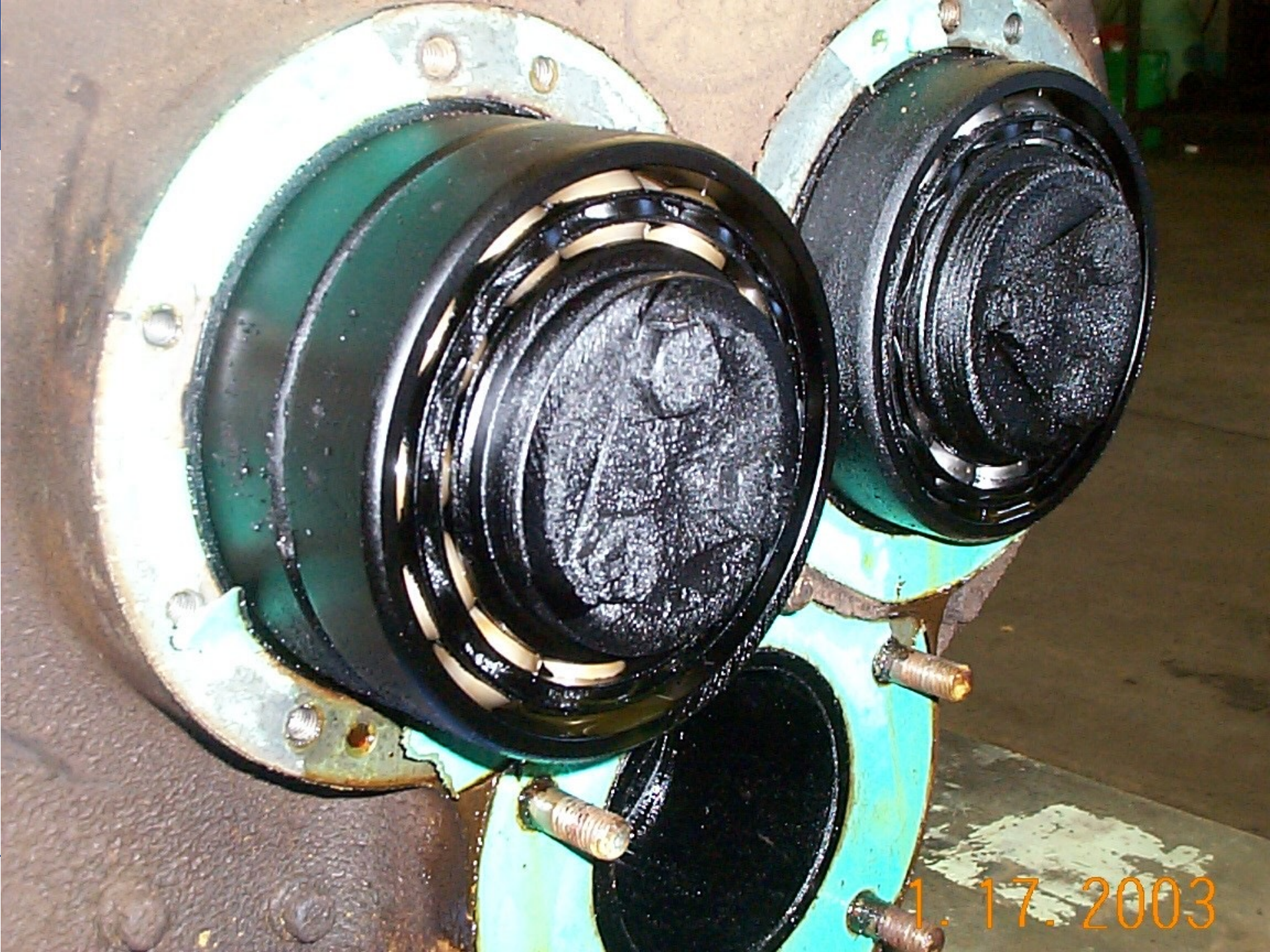

1.17.2003



# OIL FILTER BYPASS

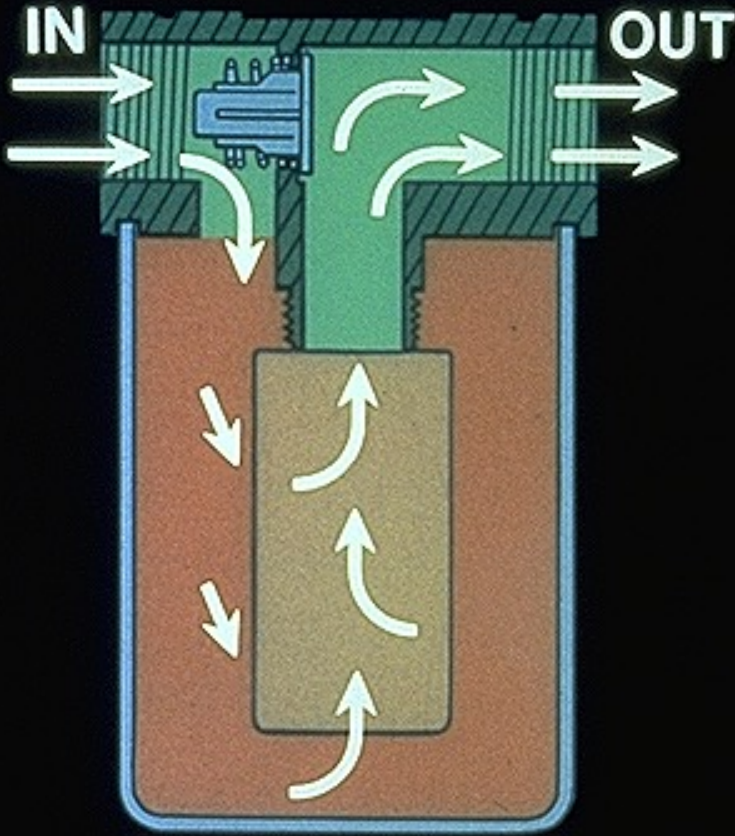

**Less Than 20 PSI  
Differential**

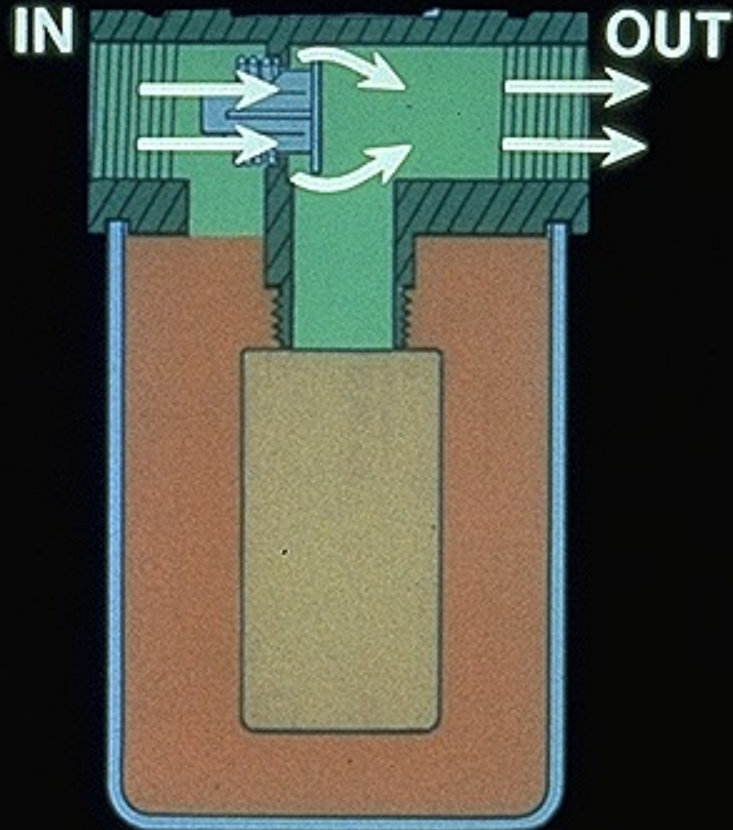

**Greater Than 20 PSI  
Differential**

# Other Important Maintenance Issues

- Condensate Sampling
- Bearing Analysis (Centrifugals)
- Bearing Analysis – Anti-friction (Rotary Screws)
- Motor Rewinding
- Trending
- Cooler cleaning
- Measuring Approach Temperature or CTD









# Approach Temperature or CTD

- Aftercooler approach temperature is 15°F
- Cooling air moving through fins is 90°F
- Compressed air leaving this aftercooler should be 105°F

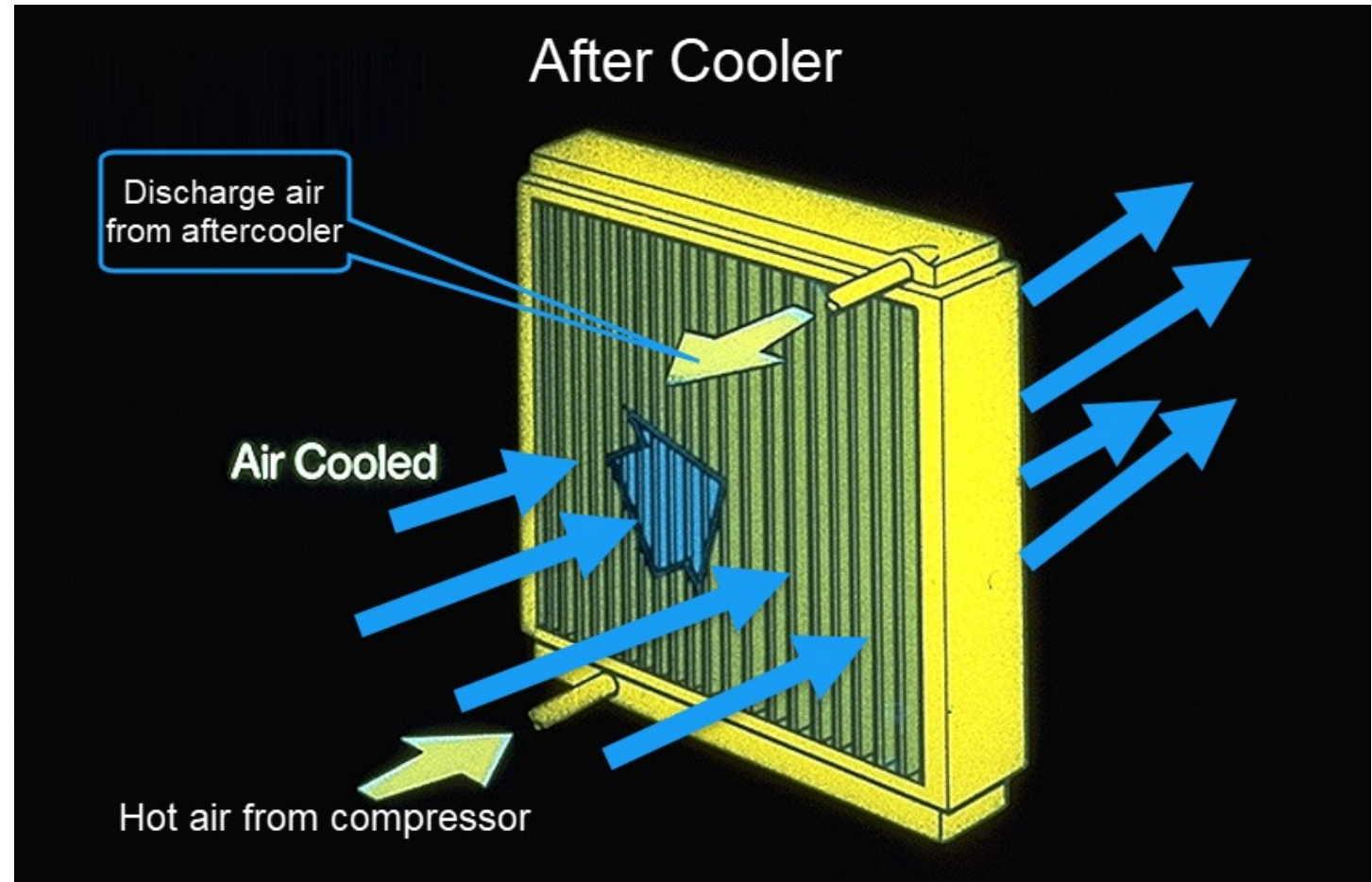





# Final Notes on Compressor Room Design

# Proper Compressor Room Design

- Creating a designated compressor room allows for better control of the compressor's air quality in addition to ensuring the compressors are kept at the proper temperature through the use of HVAC or ventilation.
- Ideally, your compressor room should be located as close to its point of use as possible. Most companies try to locate the compressor room in a centralized location to minimize the distance air must travel to reach all of its processes.
- This also helps minimize the amount of compressed air piping, pressure drop and potential leak points.

# Clearance

- Always consult your compressed air manufacturer for proper clearance required in cooling and equipment maintenance.
- For example, compressors with canopies may have doors swinging on hinges or doors needing to be completely removed.
- Each of these options will require a different type of clearance.
- Another example takes into consideration large maintenance issues, requiring the use of larger tools such as hoists or jacking equipment.
- These special circumstances need enough clearance height and floor space for maintenance personnel to access the machines.



# Summary

- In an ideal world, we would all have plenty of space, time and money to create the perfect compressed air system.
- Remember to keep the compressors cool, minimize piping pressure drop and to allow sufficient room around the equipment for service.
- Even the best engineered systems will perform poorly unless maintenance is properly performed..
- Poor maintenance practices lead to increased equipment and energy costs, downtime, production problems, poor product quality.

# Homework for Week 2 – Compression Ratio

- What's the compression ratio of the single stage compressor listed below:
  - 13.5 psia inlet pressure
  - 113.5 discharge pressure

# Homework for Week 2 – Compression Ratio

- What are some problems you are experiencing related to your compressed air system?

# Next Session 3

**Compressor Controls**  
**Intro to Airmaster+**  
**Intro to LogTool**  
**Intro to MEASUR**

# Questions?