



Industrial Fan Systems

Virtual INPLT Training & Assessment

Session 1



Welcome

- Welcome to the first fan systems Virtual INPLT training series
- Eight, 2-1/2 hour webinars, focused on Industrial Fan Systems Energy Assessment and Optimization
- These webinars will help you gain a significant understanding of your industrial fan system, undertake an energy assessment using a systems approach, evaluate and quantify energy and cost-saving opportunities using US DOE tools and resources
- Thank you for your interest!



Fan Virtual INPLT Facilitator



Ron Wroblewski, PE,
Productive Energy Solutions, LLC
Madison, Wisconsin

ron@productiveenergy.com
(608) 232-1861

Acknowledgments

- William (Bill) Hunter, PE, Airclean Systems, Seattle WA
- Eddie Radd, CFW Fans, Cape Town, SA
- William (Bill) W.T. Corey
- US Department of Energy , Advanced Manufacturing Office
- Oak Ridge National Laboratory
- United Nations Industrial Development Organization
- Air Movement and Control Association, AMCA International
- Many industrial clients – both in the US and internationally

Agenda – Session ONE

- Welcome and Introductions
- Safety and Housekeeping
- Agenda for Fan System Virtual INPLT (8 weeks)
- Today's Content:

Industrial Fan Systems Fundamentals

- Benefits of fan system optimization
- Fan efficiency and operating costs
- Ranking tool for optimization projects

MEASUR Tool

- Demonstration
- Kahoot Quiz Game
- Q&A



Safety and Housekeeping

- Safety Moment
 - Fans can be dangerous, and caution should be used around fan systems
 - Accidents can be life-threatening
- You are welcome to ask questions at any time during the webinar
- When you are not asking a question, please MUTE your mic and this will provide the best sound quality for all participants
- We will be recording all these webinars and by staying on-line and attending the meeting you are giving your consent to be recorded
 - A link to the recorded webinars will be provided, afterwards



fan Virtual INPLT Agenda

- **Week 1 – Industrial Fan Systems Fundamentals and Introduction to MEASUR**
- **Week 2 – Fan and system curves, Fan types**
- **Week 3 – Fan affinity laws, Fan system controls**
- **Week 4 – Creating a fan performance measurement plan & selecting measurement planes**
- **Week 5 – Pressure considerations, Sizing ducts and estimating losses, Optimization techniques**
- **Week 6 – Psychrometrics and air density for fan systems, System effect in fan systems**
- **Week 7 – Fan system optimization strategies, Fan system evaluation with MEASUR**
- **Week 8 – Industrial Fan System VINPLT Wrap-up Presentations**

Session 1 Learning Objectives

Class participants will:

1. Explain the benefits of optimizing fan systems;
2. Calculate the cost of operating fans in their facility;
3. Analyze and rank the optimization potential of fan systems;
4. Describe how to use MEASUR software to estimate baseline energy usage of a fan;

Industrial Energy Overview

- Industry consumes 1/3 of U.S. energy
- More than 40% of U.S. natural gas is consumed by industry
- Approximately 28% of U.S. electricity demand is industrial
- Energy is key to economic growth and maintaining U.S. jobs in manufacturing

2004 Energy Use*

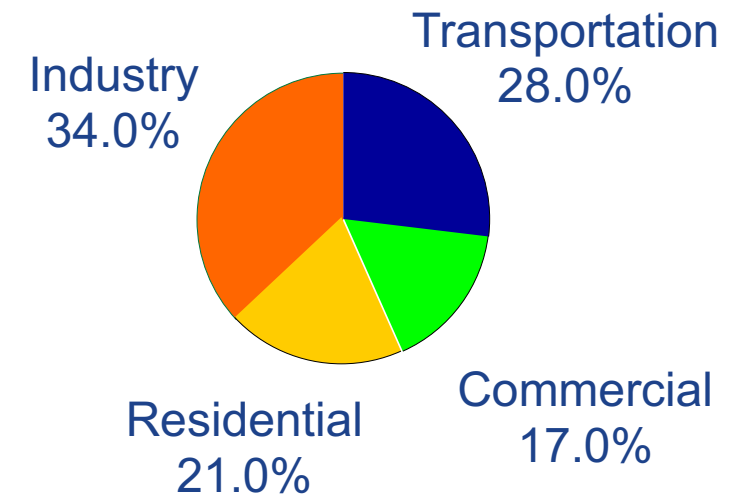

*Includes electricity losses

Source: DOE/EIA Monthly Energy Review 2004 (preliminary)

Industrial Fan Users

- Heavy Fan Users
 - Steel
 - Taconite processing
 - Cement
 - Power generation
 - Deep underground mines
- Medium Fan Users
 - Pulp and paper
 - Lime
 - Glass
 - Foundries
 - Woodworking
 - Automotive and paint booths
- Small Fan Users
 - Grain silos and processing
 - Food processing
 - Light manufacturing and assembly



Polling Question 1

Polling Question

- 1) Which industry group do you belong to?
 - A. Heavy fan user – Cement, Steel, Taconite
 - B. Heavy fan user – power generation, deep underground mining
 - C. Medium fan user – Pulp and paper, lime, automotive, glass
 - D. Small fan user – Food processing, mechanical draft boiler, etc.
 - E. Not a fan user

Polling Question 2

Polling Question

2) What is your major function in your current role at your plant?

- A. Process Engineering
- B. Operations & Maintenance (Engineering / Technical)
- C. Operations & Maintenance (Management)
- D. Plant management
- E. Corporate-level management
- F. Independent consultant / contractor
- G. Other

Axial Fans

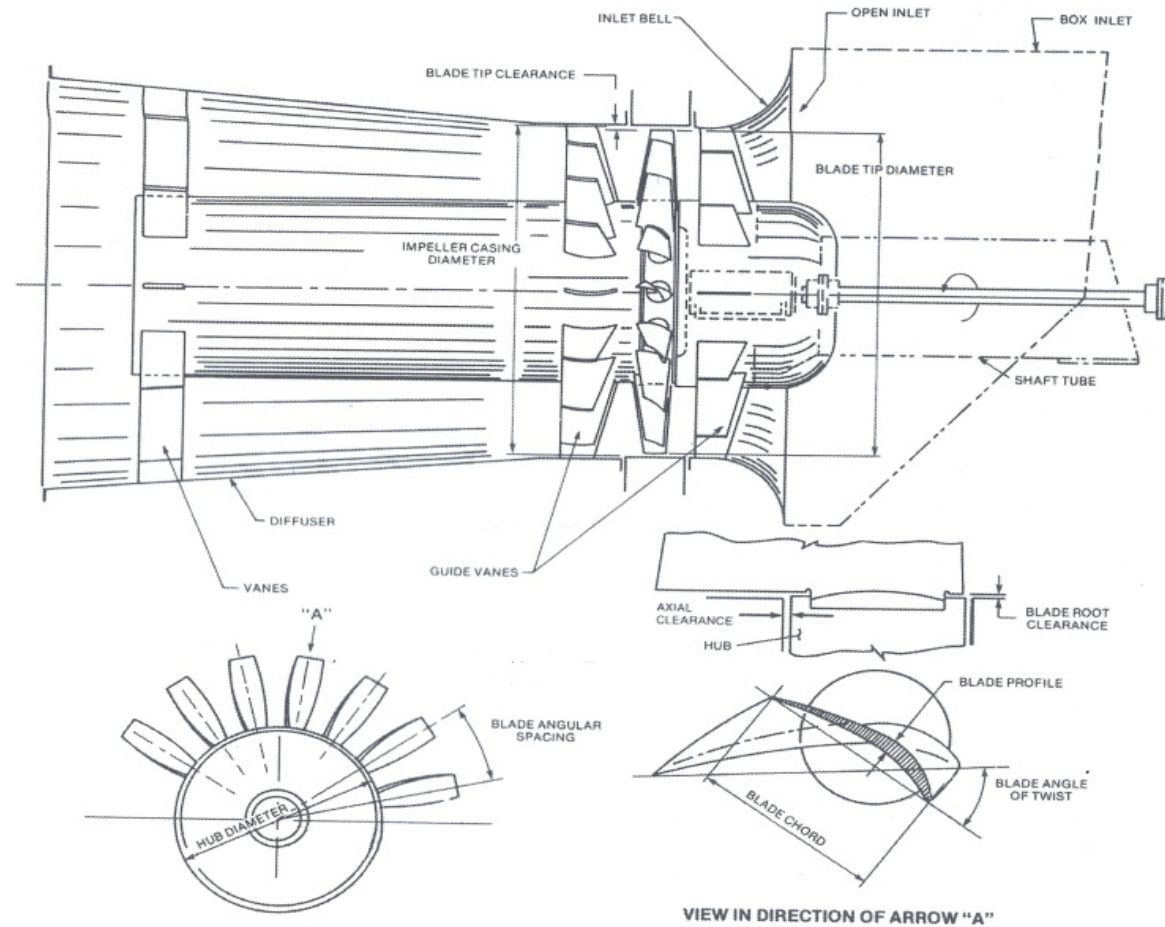

Centrifugal Fans

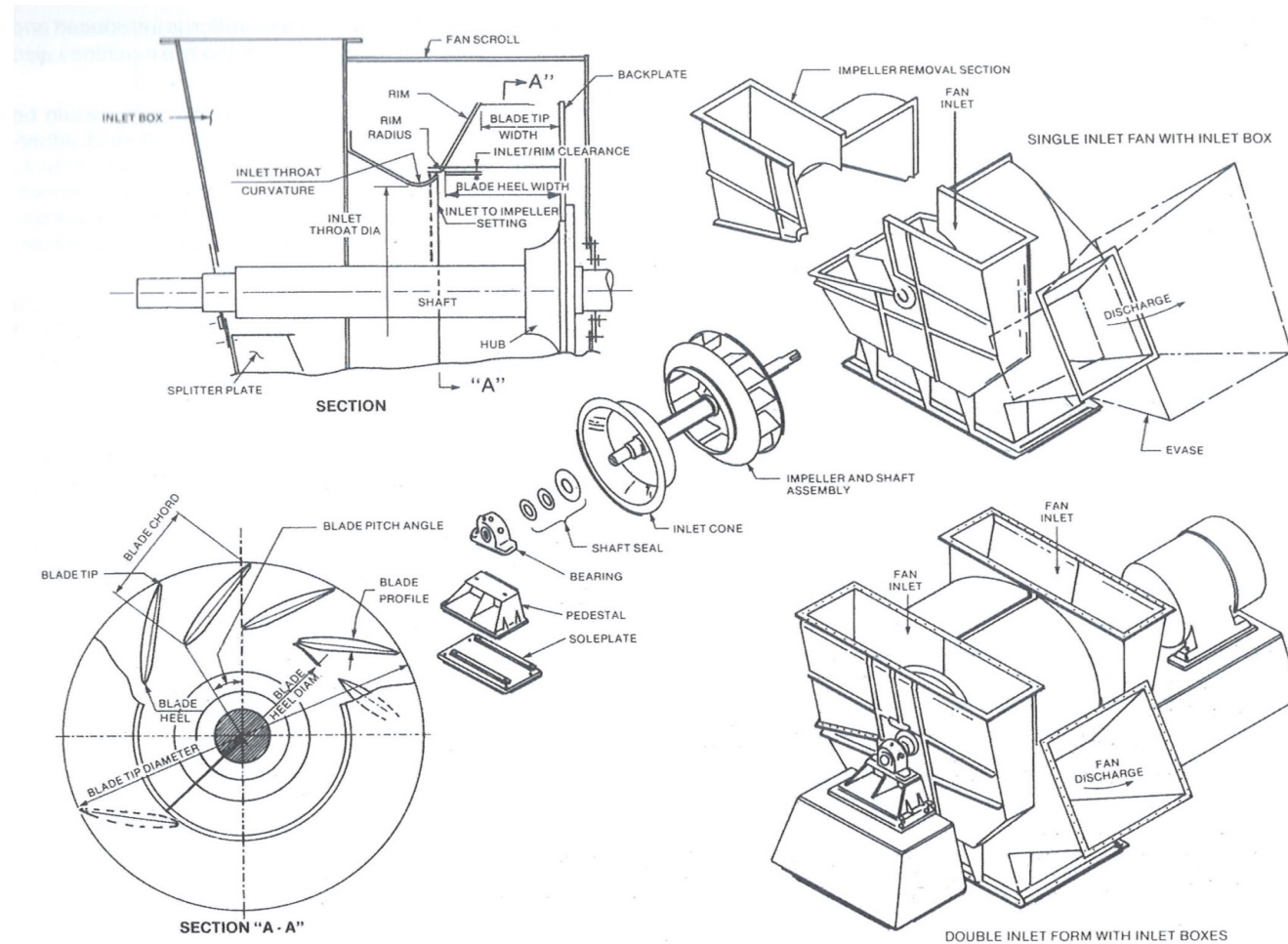

Fan Accessories and Dampers

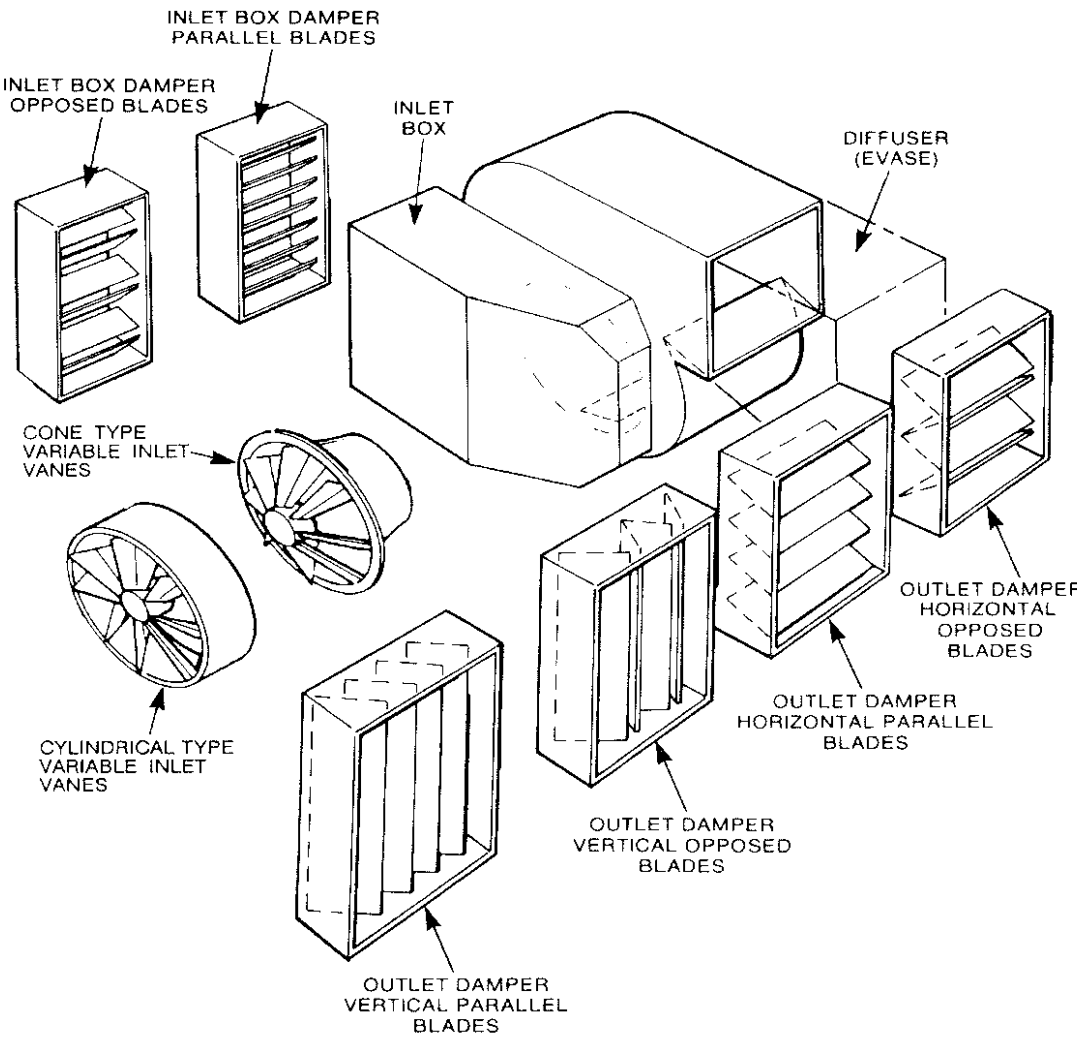

Benefits of fan system optimization

OSB Plant – Gas Flow - Before

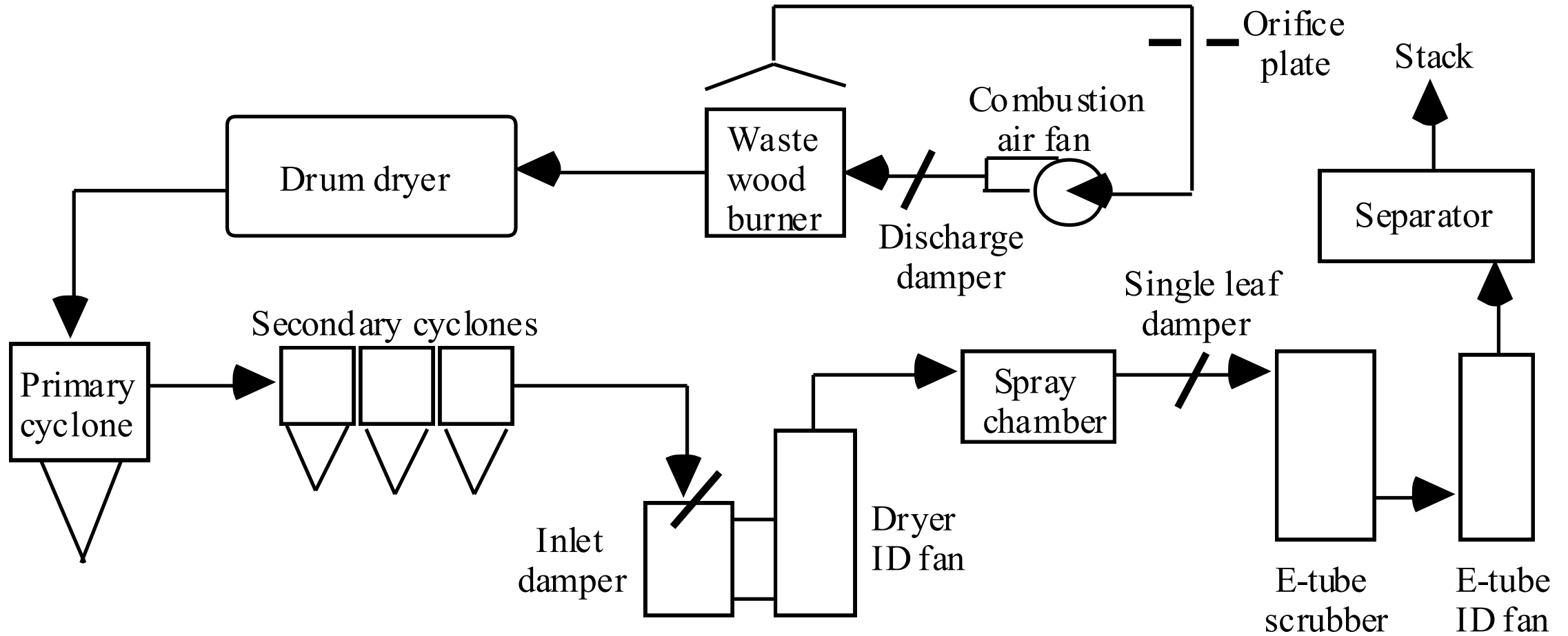

OSB Plant – Gas Flow

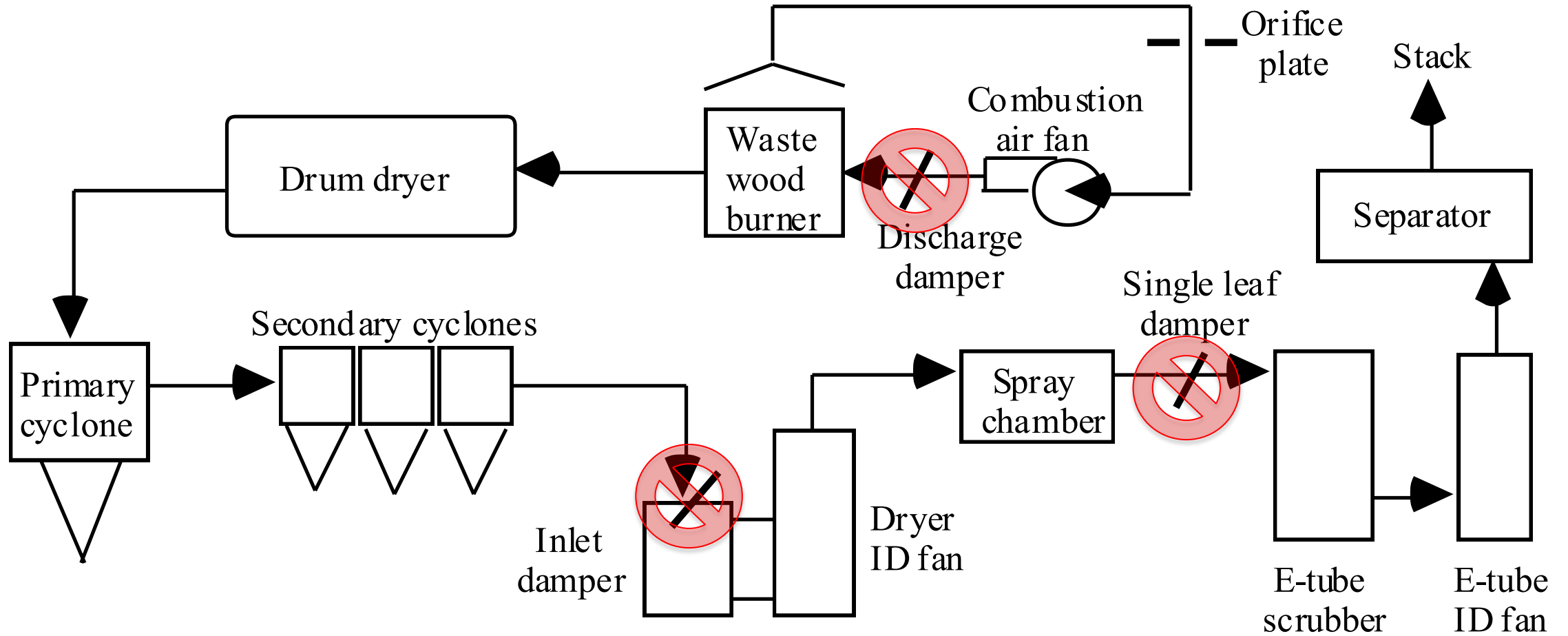

OSB Combustion Air Fan



OSB Combustion Air Fan - After

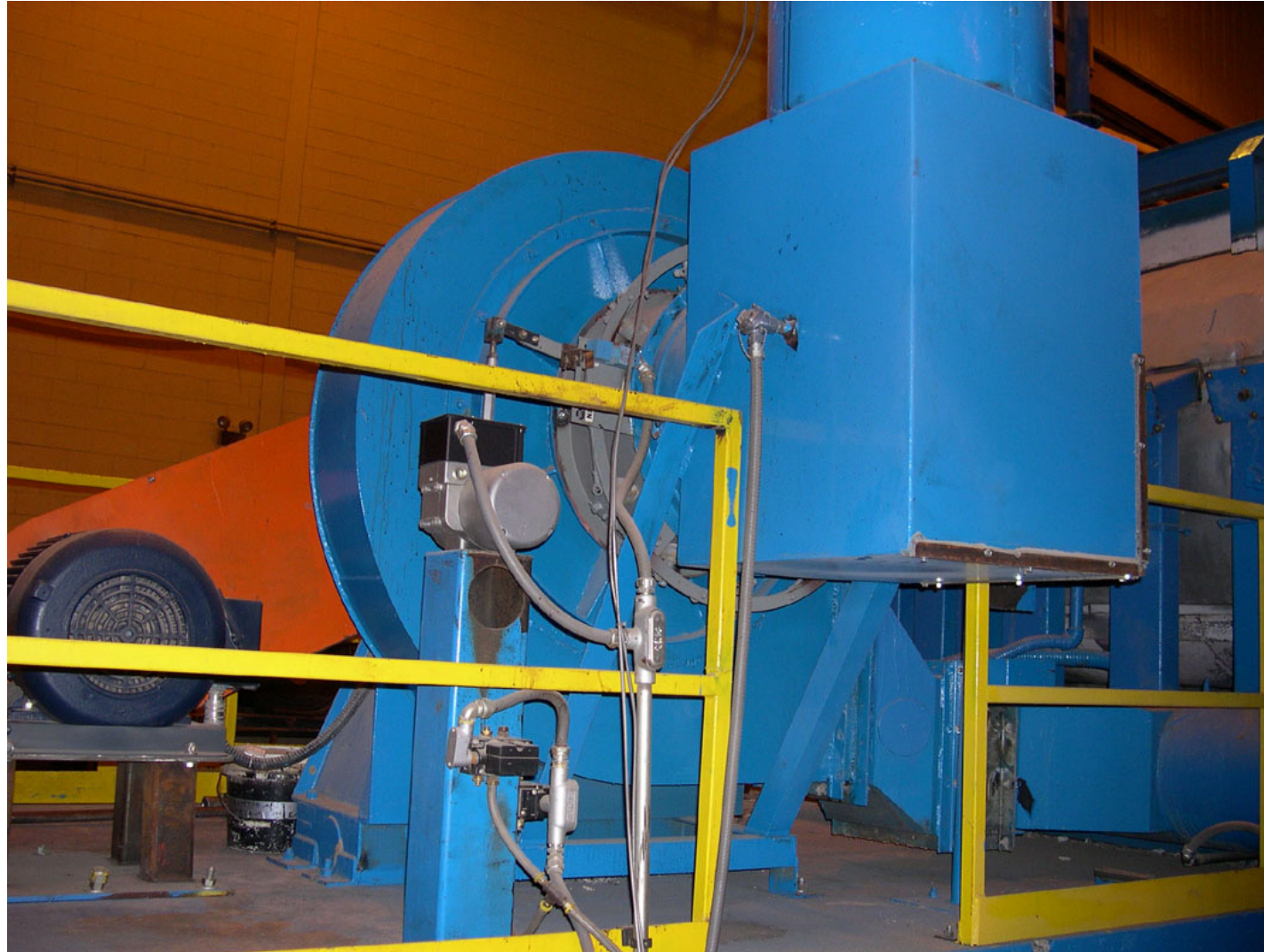

OSB Plant Combustion Air Fan

OSB Combustion air blower (1 of 2)	Units	Before	After
Damper position		Mostly Closed	Open
Flow	CFM	8,080	8,080
Pressure developed by fan	in. w.g.	42.7	12.0
Pressure required by process	in. w.g.	12.0	12.0
Pressure drop across poor ductwork	in. w.g.	2.0	0.0
Pressure drop across damper	in. w.g.	25.6	0.0
Pressure drop across orifice plate	in. w.g.	3.1	0.0
Motor Size	hp	125	40
Motor loading	bhp	94	26
Power Draw	kW	72	22
Annual energy cost	\$/yr	\$28,800	\$8,800

Next up - Fan System Optimization Discussion Questions overhead

Optimization Benefits

- Financial
- Corporate
- Production
- Maintenance
- Safety
- Environmental
- Societal



Time Magazine April 5, 2004

Small Group Activity - Optimization Benefits

- Financial
- Corporate
- Production
- Maintenance
- Safety
- Environmental
- Societal

Work with the people in your breakout room to list the possible benefits one may accrue by optimizing a fan system.

Note – Even if a particular benefit might not apply in all cases list it anyway.

Fan system operating costs

Why Estimate Fan Costs?

Also known as baselining?

1. Documents current system status
2. Allows accurate savings estimates
3. Enables you to document results to management after project completion.

Baselining Methods

- Volt-Ammeter method *Good*
 - Simple, readily available instrument, voltage measured phase-to-phase
- Power Meter method *Better*
 - Meter more expensive, but better accuracy
- Recording power meter *Best*
 - Captures variation over time and actual operating schedule
- Fan power-law method *Used as crosscheck*
 - Requires process information

Motor characteristic curves

Red = Efficiency

Yellow = Power Factor

White = %FLA

- MEASUR uses this type of motor data to accurately estimate power factor (and thus power) from the measured amps and volts
- Caution: if capacitors are wired in at the motor, use a power meter and enter the kW in MEASUR instead of amps and volts

These curves are for a 1200 rpm 200 hp 460-volt AC induction motor

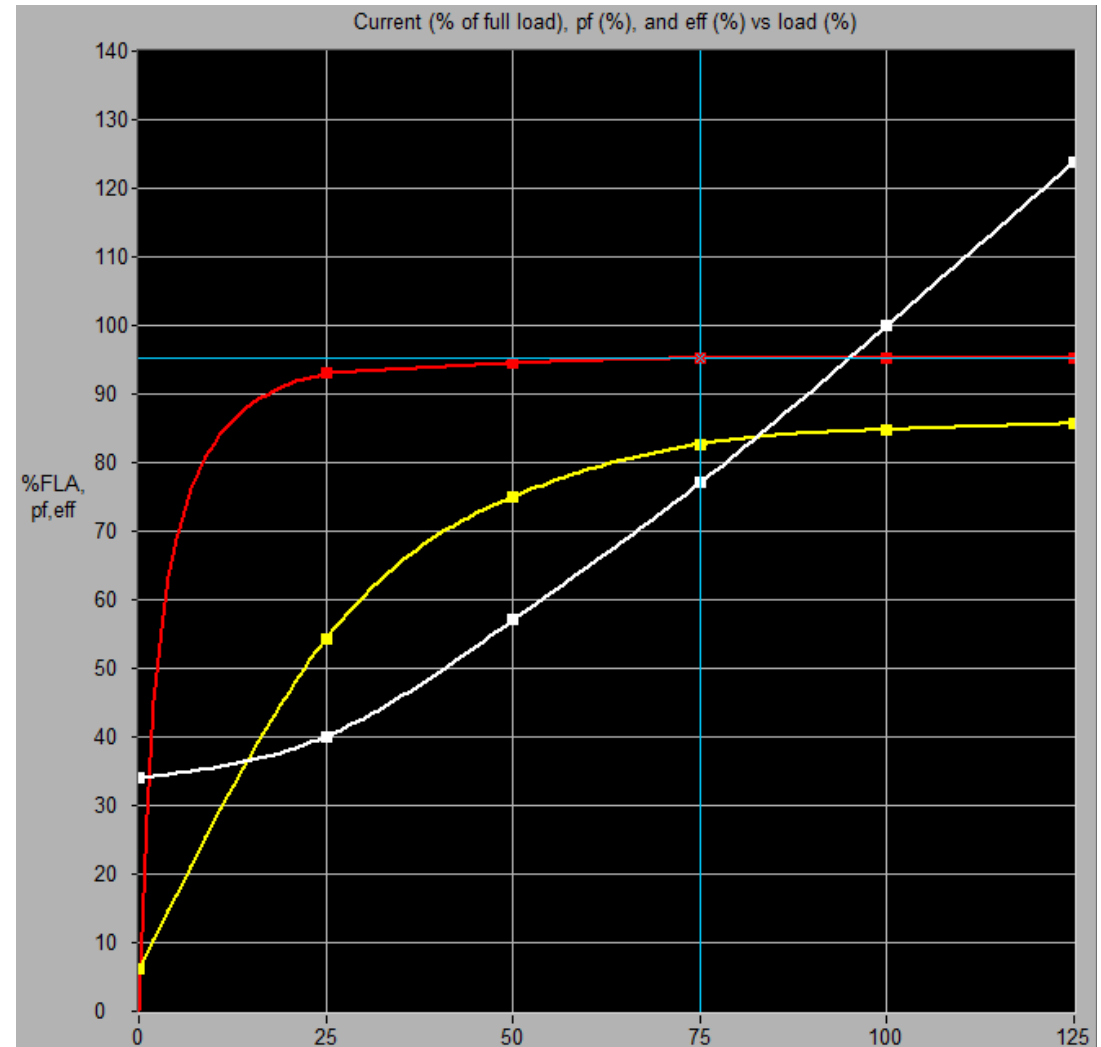

Determining your Average Electric Rate

1. Total bill amount (\$)
2. Total energy used (kWh)

$$\text{Electric Rate} = \frac{\text{Bill Amount}}{\text{Energy Used}}$$

Where:

Electric Rate = average cost in \$/kWh

Bill Amount = total bill amount for that period in \$

Energy used = kWh used in that billing period

Next up: Fan System Data Sheet

Fan System Data Sheet - Example

Required Data:

1. Name of Fan System Combustion air fan for core dryer (same as surface dryer)
2. (a) Motor Nameplate HP 125 hp and (b) Motor Efficiency 0.90
3. (a) Measured Power Draw _____ - _____ kW (if power meter available)
OR
(b) Motor Voltage and Amperes:

Phase	VOLTS	AMPS
AB	460	109
BC	459	110
AC	464	103
Average	461.0	107.3

4. Operating Hours 8760 hr/yr
5. Electric Rate 0.05 \$/kWh (Calculate this by dividing the total bill amount by the total kilowatt hours.)

Fan System Data Sheet – Example Cont.

Optional Data:

6. Type of Fan Impeller Radial (if known)
7. (a) Fan Pressure Rise 42.7 in. H₂O (if known)
(b) Damper Pressure drop 30.7 in. H₂O (if known)
(c) Pressure Required for Process 12 in. H₂O (if known)
8. Fan Flow 8.080 cfm (if known)
9. Fan Speed 2,470 rpm (if known)
10. Fan Impeller Size 24 inches (if known)
11. Air Stream Temperature 128°F
12. Gas Other Than Air Air

Volt Ammeter Method Worksheet Example

Step 1: Calculate electrical power drawn by the motor

From the Fan System Data Sheet, enter average amps and volts in Boxes 1 and 2.

Average Current I_{avg}

107.3

amps Box 1

Average Voltage V_{avg}

461

Volts Box 2

Enter the power factor in Box 3 in decimal form. Use 0.8 if unknown.

Power Factor PF

0.8

Decimal form Box 3

$$H_e = \frac{V_{avg} \times I_{avg} \times PF \times \sqrt{3}}{1000}$$

$$H_e = \frac{461 \times 107.3 \times 0.8 \times 1.732}{1000} \rightarrow 68.5 \text{ kW}$$

Use equation above to calculate the power, H_e . Enter the result in Box 4. (Note: the square root of 3 is 1.732)

Power H_e

68.5

kW Box 4

Volt Ammeter Method Worksheet Example – Cont.

Step 2: Calculate annual energy use

Enter the operating hours of your fan system in Box 5.

Operating hours

8760

hrs/year Box 5

$$E_a = H_e \times \text{Operating_Hours}$$

$$E_a = 68.5 \times 8760 \rightarrow 600,060 \text{ kWh/yr}$$

Use equation above to calculate E_a , the annual energy. Enter the result in Box 6.

Annual Energy used,
 E_a

600,060

kWh/year Box 6

Step 3: Calculate annual energy cost:

From the Fan System Data Sheet, enter the Electric Rate in Box 7.

Electric Rate, \$ER

\$0.05

\$/ kWh Box 7

$$\text{Energy_Cost} = E_a \times \text{Electric_Rate}$$

$$\text{Energy_Cost} = 600,060 \times 0.05 \rightarrow \$30,003 \text{ /yr}$$

Use equation above (3.3) to calculate Annual Energy Cost. Enter the result in Box 8.

Annual Energy Cost,
\$EC

\$30,003

\$/ Year Box 8

Fan System Data Sheet - Provided

Required Data:

1. Name of Fan System **Core Dryer Induced Draft Fan**
2. (a) Motor Nameplate HP **350** hp and(b) Motor Efficiency _____
3. (a) Measured Power Draw _____ - _____ kW (if power meter available)
OR
(b) Motor Voltage and Amperes:

Phase	VOLTS	AMPS
AB	457	260
BC	459	264
AC	466	255
Average	461.	260

4. Operating Hours **8760** hr/yr
5. Electric Rate **0.05** \$/kWh (Calculate this by dividing the total bill amount by the total kilowatt hours.)

Polling Question 3

Polling Question

- 2) For the data presented on the dryer induced draft fan, what do you think would be a good assumption for the power factor?
- A. 60%
 - B. 70%
 - C. 80%
 - D. 90%
 - E. 100%
 - F. Other

Power calculation activity

Calculate the power in kW using the formula on the volt-ammeter method worksheet, and enter your result in the private chat to Wei

Annual energy cost calculation activity

If the ID fan operates 8760 hours per year and the average cost of electricity is \$0.05 /kWh,

Calculate the power in annual energy in kWh/yr and annual energy cost using the formulas on the volt-ammeter method worksheet, and enter your result in the private chat to Wei

Fan Power Law Method Example

Step 1a: Calculate brake horsepower (bhp)

From the Fan System Data Sheet, enter the Flow and Pressure in Boxes 1 and 2.

Flow Required Q 8080 cfm Box 1

Pressure Required P 12 in. w.g. Box 2

Enter the Compressibility Factor drawn from Table (3.1) below in Box 3.

Compressibility Factor K_p 1.0 Box 3

Enter the achievable efficiency in Box 4 in decimal form.

Fan Efficiency η 0.68 Decimal Box 4

$$H = \frac{Q \times P \times K_p}{6362 \times \eta}$$

$$H = \frac{8,080 \times 12 \times 1.0}{6362 \times 0.68}$$

$$H = 22.4 \text{ hp}$$

Use equation above to calculate the shaft power, H. Enter the result in Box 5.

Shaft Power H 22.4 bhp Box 5

Fan Power Law Method Example

Step 1b: Calculate motor input power (kW)

Enter the efficiency of the motor in Box 6 in decimal form.

Motor Efficiency η_m

0.9

Box

Enter the efficiency of the belt-drive in Box 7 in decimal form.

Drive Efficiency η_d

0.97

Box

$$H_e = \frac{H \times 0.746}{\eta_m \times \eta_d}$$

$$H_e = \frac{22.4 \times 0.746}{0.90 \times 0.97} \rightarrow H_e = 19.1 \text{ kW}$$

Calculate the electrical power H_e using equation above and enter it into Box 8.

H_e

19.1

kW

Box

Fan Power Law Method Example

Step 2: Calculate annual energy use

Carry result forward from Step 1b.

Next, enter the operating hours of your fan system in Box 9.

H_e	19.1	kW	Box
Operating Hours	8760	hrs/year	Box

$$E_a = H_e \times \text{Operating_Hours}$$
$$E_a = 19.1 \times 8760 \rightarrow 167,316 \text{ kWh/yr}$$

Use equation above to calculate E_a , the annual energy used. Enter the result in Box 10.

Annual Energy used, E_a	167,316	kWh/year	Box
---------------------------	---------	----------	-----

Step 3: Calculate annual energy cost

From the Fan System Data Sheet, enter the Electric Rate in Box 11.

Electric Rate	\$0.05	\$/ kWh	Box
---------------	--------	---------	-----

$$\text{Energy_Cost} = E_a \times \text{Electric_Rate}$$

$$\text{Energy_Cost} = 167,316 \times 0.05$$

$$\text{Energy_Cost} = \$8,336 \text{ /yr}$$

Use equation above to calculate the Annual Energy Cost. Enter the result in Box 12.

Annual Energy Cost	\$8,366	\$/ Year	Box
--------------------	---------	----------	-----

Comparison of Cost Estimating Methods

Combustion Air Fan – OSB Plant

	Volt-Ammeter Measured	kW Meter Measured	Fan Power-Law-Required
KW	68.5	72	19.1 kW
Annual Energy	600,060	630,720	167,316 kWh
Annual Cost	\$30,003	\$31,536	\$8,366/yr
Remarks	PF assumption was off a little	Existing – measured	Theoretical Optimized

Ranking potential fan optimization projects

Applying the checklist - example

Fan System Optimization Checklist

Instructions: Use this checklist to qualitatively select the top optimization projects for FSAT analysis. Make a copy of this list for each of your major systems, then go through the list and add up the points for the conditions that apply. **If there are any control, production & maintenance, or system effect indicators, then add points for size and run hours as follows:** *If the system operates more than 4000 hours add a point. **If the system is over 100 hp add a point per 100 hp (200 hp = 2 points, 300 hp = 3 points, etc.). Also add a point or points if production or maintenance problems are severe. Two or more points can indicate a good optimizations opportunity. Four or more points probably indicate a very good opportunity. **Note:** Fans with adjustable speed drives usually are not good candidates for optimization.

Fan System _____

Are there problems with the system? _____

Points** 1 _____ Motor _____ hp 1 _____ Points* Operating hours _____ Tally the points _____

Control	Production & Maintenance	System Effect
Points	Points	Points
2__ Motor overloads unless damper restricts flow	2__ Too much flow or pressure for production	2__ 90° turn right at fan outlet or inlet
2__ Spill or bypass	2__ Unstable or hard to control system	1__ 90° turn near fan outlet or inlet
2__ Discharge damper	2__ Unreliable system breaks down regularly	2__ Dirt leg at bottom of inlet duct
1__ Inlet damper	1__ Not enough flow or pressure for production	1__ No outlet duct
1__ Variable inlet vane	1__ System is excessively noisy	1__ Restricted or sharp inlet
1__ System Damper	1__ Buildup on fan blades	
1__ Damper is mostly closed	1__ Need to weld ductwork cracks regularly	
1__ Equipment runs longer hours than required	1__ Radial fan handling clean air	

Facility/Contact/phone/fax: _____

Applying the checklist – Combustion air blower example

Fan System Optimization Checklist (Example)

Instructions: Use this checklist to qualitatively select the top optimization projects for FSAT analysis. Make a copy of this list for each of your major systems, then go through the list and add up the points for the conditions that apply. **If there are any control, production & maintenance, or system effect indicators, then add points for size and run hours as follows:** *If the system operates more than 4000 hours add a point. **If the system is over 100 hp add a point per 100 hp (200 hp = 2 points, 300 hp = 3 points, etc.). Also add a point or points if production or maintenance problems are severe. Two or more points can indicate a good optimizations opportunity. Four or more points probably indicate a very good opportunity. **Note:** Fans with adjustable speed drives usually are not good candidates for optimization.

Fan System Combustion air blower on core dryer (surface dryer similar)

Are there problems with the system? System seems to be way too big

Points**

1 1 Motor 125 hp 1 1

Points*

Operating hours 24/7/365=8,000+

Tally the points 1+1+2+1+1=6

Control	Production & Maintenance	System Effect
Points	Points	Points
2__ Motor overloads unless damper restricts flow	2__ Too much flow or pressure for production	2__ 90° turn right at fan outlet or inlet
2__ Spill or bypass	2__ Unstable or hard to control system	1__ 90° turn near fan outlet or inlet
2 <u>2</u> Discharge damper	2__ Unreliable system breaks down regularly	2__ Dirt leg at bottom of inlet duct
1__ Inlet damper	1__ Not enough flow or pressure for production	1__ No outlet duct
1__ Variable inlet vane	1__ System is excessively noisy	1__ Restricted or sharp inlet
1__ System Damper	1__ Buildup on fan blades	
1 <u>1</u> Damper is mostly closed	1__ Need to weld ductwork cracks regularly	
1__ Equipment runs longer hours than required	1 <u>1</u> Radial fan handling clean air	

Applying the checklist – Dryer ID fan example

Fan System Optimization Checklist

Instructions: Use this checklist to qualitatively select the top optimization projects for FSAT analysis. Make a copy of this list for each of your major systems, then go through the list and add up the points for the conditions that apply. **If there are any control, production & maintenance, or system effect indicators, then add points for size and run hours as follows:** *If the system operates more than 4000 hours add a point. **If the system is over 100 hp add a point per 100 hp (200 hp = 2 points, 300 hp = 3 points, etc.). Also add a point or points if production or maintenance problems are severe. Two or more points can indicate a good optimization opportunity. Four or more points probably indicate a very good opportunity. **Note:** Fans with adjustable speed drives usually are not good candidates for optimization.

Fan System OSB Dryer Induced Draft Fan

Are there problems with the system? No

Points**

1 3 Motor 350 hp 1 1

Points*

Operating hours 8760

Tally the points 3+1+1+1+1=7

Control	Production & Maintenance	System Effect
Points	Points	Points
2__ Motor overloads unless damper restricts flow	2__ Too much flow or pressure for production	2__ 90° turn right at fan outlet or inlet
2__ Spill or bypass	2__ Unstable or hard to control system	1__ 90° turn near fan outlet or inlet
2__ Discharge damper	2__ Unreliable system breaks down regularly	2__ Dirt leg at bottom of inlet duct
1 <u>1</u> Inlet damper	1__ Not enough flow or pressure for production	1__ No outlet duct
1__ Variable inlet vane	1__ System is excessively noisy	1__ Restricted or sharp inlet
1 <u>1</u> System Damper	1__ Buildup on fan blades	
1 <u>1</u> Damper is mostly closed	1__ Need to weld ductwork cracks regularly	
1__ Equipment runs longer hours than required	1__ Radial fan handling clean air	

Facility/Contact/phone/fax:

Introduction to DOE MEASUR tool

MEASUR

Application Edit

U.S. DEPARTMENT OF ENERGY
Energy Efficiency & Renewable Energy

Add New

MEASUR

Welcome to the most efficient way to manage and optimize your facilities' systems and equipment.

Create an assessment to model your system and find opportunities for efficiency or run calculations from one of our many property and equipment calculators. Get started with one of the following options.

Create Assessment

Model a system and explore multiple optimization scenarios.

- Create Pump Assessment**
formerly DOE Pumping System Assessment Tool (PSAT)
- Create Process Heating Assessment**
formerly DOE Process Heating Assessment and Survey Tool (PHAST)
- Create Fan Assessment**
formerly DOE Fan System Assessment Tool (FSAT)
- Create Steam Assessment**
formerly DOE Steam System Modeler Tool (SSMT)
- Create Treasure Hunt**
Energy efficiency calculators for facilitating a Treasure Hunt
- Create Waste Water Assessment**
Based on the Bio-Tiger Model for Wastewater Treatment Plants

Properties & Equipment Calculators

Generate detailed properties and test a variety of adjustments.

- General
- Compressed Air
- Fans
- Lighting
- Motors
- Process Cooling
- Process Heating
- Pumps
- Steam
- Waste Water

Inventory Management

Create and manage equipment inventory.

- Create Motor Inventory**
based on DOE's MotorMaster+ tool

Home

- All Assessments
 - Boiler ID fan 75% firing rate -
 - Kiln Fan
 - Acme
 - Combustion air blower
 - ACME International
 - ACME International 60% firing rate -
 - ACME International 75% firing rate -
 - ACME International 100% firing rate -
 - ACME
 - Boiler ID fan - 100% firing rate -
 - Boiler ID fan - 60% firing rate -
 - Boiler ID fan - 75% firing rate -
 - Examples
 - Toy Factory
 - Treasure Hunt Example
 - Steam Example
 - Process Heating - Fuel Example
 - Fan Example
 - Pump Example
 - Boiler ID fan 75% firing rate -
 - Boiler ID fan 60% firing rate -

Data Exploration

- All Calculators
 - General
 - Compressed Air
 - Fans
 - Lighting
 - Motors
 - Process Cooling
 - Process Heating
 - Pumps
 - Steam
 - Waste Water

MEASUR

Developed by the U.S. Department of Energy (DOE)

MEASUR will:

- Calculate fan system energy use
- Determine system efficiency
- Quantify optimization savings

Fan System Assessment Tool

When using MEASUR keep in mind that:

- *MEASUR is best for the big picture.*
- *MEASUR requires good input data.*
- *MEASUR requires you to know which type of fan is suited for your load.*
- *MEASUR analyzes one load point. (but we can group multiple load points to get an overall picture)*
- *MEASUR will not tell you what to do to improve the system.*

MEASUR Computer Requirements

Computer running one of the following operating systems:

- Windows
- Linux
- Mac OS

Key Points / Action Items



1. *Remember to include the non-energy benefits when you are putting together the business plan to justify a fan system optimization project*
2. *Use a power meter, if possible, when measuring the energy draw of a fan system. If no power meter is available, check carefully for the presence of capacitors*
3. *Remember that the Fan System Optimization Checklist is meant as a tool to prioritize potential projects*



Homework #1

- Make a list of the top 10 fans you think might bear fruit for potential optimization projects
- Use the checklist to rank the potential projects
- Collect power draw information for the top 3-5 potential fan projects, either kW or amps and volts
- Collect motor nameplate information for the top 3-5 projects
 - HP
 - Efficiency
 - FLA
 - Volts
- Estimate the annual operating cost of the top 3-5 fans

Thank You all for attending today's webinar.

See you all on next Thursday –

If you have specific questions, please stay online and we will try and answer them.

**Alternately, you can email questions to me at
ron@productiveenergy.com**